



Technical Support Center: Piperidine N-Alkylation Optimization

Author: BenchChem Technical Support Team. **Date:** May 2026

Compound of Interest

Compound Name: 2-(3-Hydroxypiperidin-1-yl)acetic acid
CAS No.: 1217862-95-7
Cat. No.: B578404

[Get Quote](#)

Status: Online | Agent: Senior Application Scientist | Ticket: #PIP-ALK-OPT



Executive Summary: Method Selection Matrix

Before optimizing, ensure you have selected the correct synthetic pathway for your electrophile. Use the decision tree below to validate your approach.

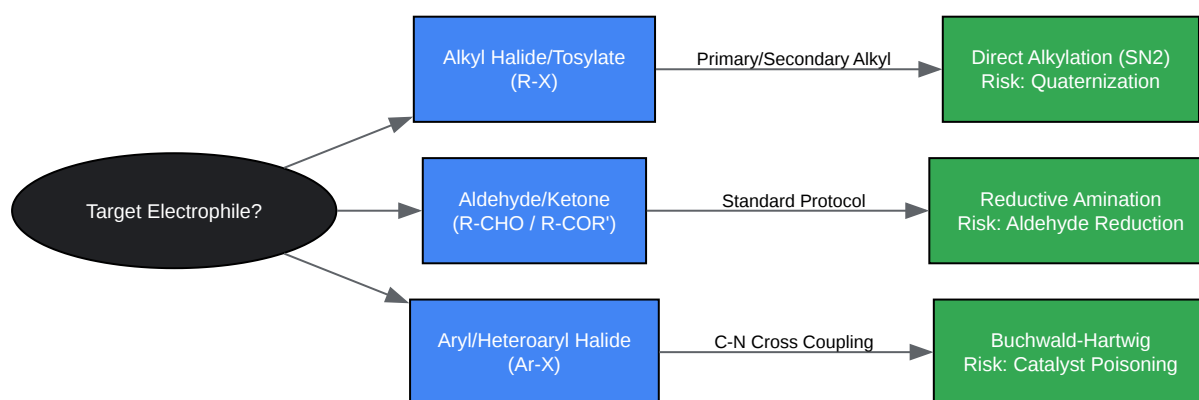

[Click to download full resolution via product page](#)

Figure 1: Decision matrix for selecting the optimal synthetic route based on electrophile type.

Module 1: Direct N-Alkylation ()

Best for: Primary and unhindered secondary alkyl halides. Common Issue: Over-alkylation (Quaternization) and poor conversion.[1]

Troubleshooting Guide

Q: Why is my reaction producing significant quaternary ammonium salt? A: Piperidine is a secondary amine; the product is a tertiary amine, which is often more nucleophilic than the starting material due to inductive donation from the new alkyl group. This leads to a "runaway" reaction.[2]

- Protocol Adjustment:
 - Stoichiometry: Use a deficiency of the alkyl halide (0.8 eq) relative to piperidine, or a large excess of piperidine (2–3 eq) if the piperidine is cheap/volatile.
 - Addition Mode: Do not dump reagents. Dissolve the alkyl halide in solvent and add it dropwise via syringe pump over 1–2 hours to keep its instantaneous concentration low [1].
 - Base Switch: Switch from homogeneous bases (like TEA) to heterogeneous inorganic bases (K_2CO_3 or Cs_2CO_3) in MeCN. The surface area effects can sometimes modulate the rate [2].

Q: My reaction is stalled at 50% conversion. Should I heat it? A: Heating increases the rate of both mono-alkylation and quaternization. Before heating, check the leaving group.

- Finkelstein Modification: If using an alkyl chloride, add 10–20 mol% NaI or TBAI (Tetrabutylammonium iodide). This generates a transient, highly reactive alkyl iodide in situ [3].
- Solvent Polarity: Ensure you are using a polar aprotic solvent (DMF, MeCN) to solvate the cation and leave the piperidine "naked" and reactive.[1]



Optimization Data: Base & Solvent Effects

Parameter	Recommendation	Mechanistic Rationale
Solvent	Acetonitrile (MeCN)	Best balance of polarity and ease of removal. Promotes without trapping nucleophile.
Alt. Solvent	DMF	Higher boiling point, better for solubility, but difficult to remove during workup.
Base	Cs_2CO_3	"Cesium Effect": Higher solubility in organic solvents and larger cation radius promotes looser ion pairing, enhancing nucleophilicity [2].
Base	K_2CO_3	Standard, cheap. Requires vigorous stirring (heterogeneous).
Temp	0°C → RT	Start cold to suppress over-alkylation; warm only if TLC shows no progress.

Module 2: Reductive Amination

Best for: Aldehydes/Ketones; avoiding quaternary salt formation. Common Issue: Reduction of the carbonyl before imine formation.



Troubleshooting Guide

Q: I see the alcohol byproduct (reduced aldehyde) instead of the amine. A: This indicates the reducing agent is reacting with the aldehyde before the iminium ion is formed.

- Solution: Use Sodium Triacetoxyborohydride (STAB) instead of Sodium Cyanoborohydride. STAB is less reactive toward neutral aldehydes and selectively reduces the protonated iminium ion.

- **Stepwise Protocol:** Pre-stir the piperidine and aldehyde in solvent (DCM or DCE) with a drying agent (MgSO_4) or molecular sieves for 2 hours before adding the reducing agent. This forces the equilibrium toward the imine/enamine [4].

Q: The reaction is sluggish with a ketone. A: Ketones are sterically hindered and form imines slowly.

- **Catalysis:** Add a Lewis Acid (e.g., $\text{Ti}(\text{O}i\text{Pr})_4$) or a Brønsted acid (Acetic Acid, 1 eq). Titanium(IV) isopropoxide is particularly effective as it acts as both a Lewis acid and a water scavenger, driving imine formation [5].



Standard Protocol: STAB Method

- **Mix:** Dissolve piperidine (1.0 eq) and Aldehyde (1.1 eq) in DCE (0.2 M).
- **Acidify:** Add Acetic Acid (1.0 eq) if the substrate is basic or unreactive.
- **React:** Stir 30 min at RT.
- **Reduce:** Add STAB (1.5 eq) in one portion.
- **Quench:** After 2–4 h, quench with sat. NaHCO_3 .



Module 3: Buchwald-Hartwig Arylation

Best for: Aryl halides (Ar-Cl, Ar-Br, Ar-I). Common Issue: Catalyst poisoning and low yield with hindered amines.



Troubleshooting Guide

Q: My catalyst turns black and precipitates immediately. A: This is "Palladium Black" formation, indicating ligand dissociation and catalyst decomposition.

- **Oxygen Contamination:** Ensure rigorous degassing. Sparging with Argon for 15 mins is often insufficient for sensitive catalysts. Use freeze-pump-thaw cycles if possible.
- **Ligand Choice:** For secondary amines like piperidine, RuPhos or DavePhos are superior. They are bulky, electron-rich phosphines that facilitate the reductive elimination step, which

is often the rate-determining step for hindered amines [6].

Q: Which base should I use for base-sensitive substrates? A: NaOtBu is standard but strong (pKa ~17).

- Alternative: Use Cs₂CO₃ or K₃PO₄ in dioxane or toluene. These are milder but require higher temperatures (80–100°C).

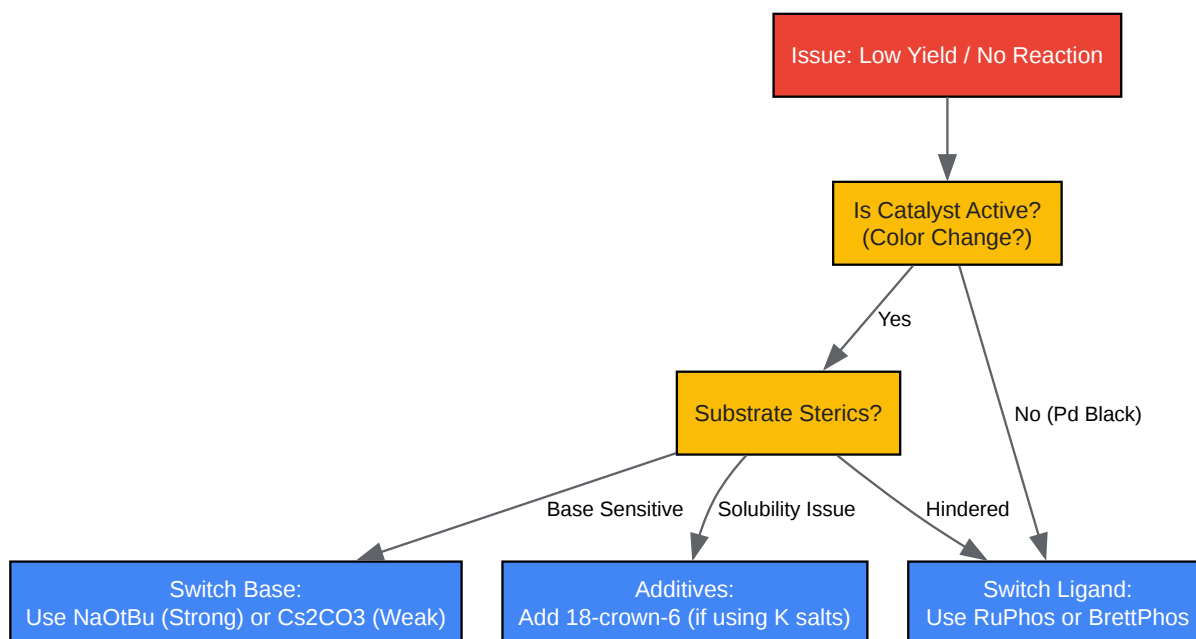

[Click to download full resolution via product page](#)

Figure 2: Troubleshooting logic for Palladium-catalyzed N-arylation.



References

- Salvatore, R. N., et al. (2001). "Synthesis of secondary amines." *Tetrahedron*, 57(37), 7785-7811. [Link](#)
- Flessner, T., & Doye, S. (1999). "Cesium carbonate: A powerful base for the alkylation of amines." *Journal of Practical Chemistry*, 341(2), 186-190. [Link](#)

- Pazio, A., et al. (2015). "Nucleophilic substitution: Finkelstein reaction." Organic Chemistry Portal. [Link](#)
- Abdel-Magid, A. F., et al. (1996).[3] "Reductive Amination of Aldehydes and Ketones with Sodium Triacetoxyborohydride." The Journal of Organic Chemistry, 61(11), 3849-3862. [Link](#)
- Bhattacharyya, S. (1995). "Titanium(IV) isopropoxide mediated reductive amination of carbonyl compounds." Synlett, 1995(10), 1079-1080. [Link](#)
- Surry, D. S., & Buchwald, S. L. (2008). "Biaryl Phosphane Ligands in Palladium-Catalyzed Amination." Angewandte Chemie International Edition, 47(34), 6338-6361. [Link](#)

Need Custom Synthesis?

BenchChem offers custom synthesis for rare earth carbides and specific isotopic labeling.

Email: info@benchchem.com or [Request Quote Online](#).

Sources

- 1. pdf.benchchem.com [pdf.benchchem.com]
- 2. masterorganicchemistry.com [masterorganicchemistry.com]
- 3. [Amine synthesis by reductive amination \(reductive alkylation\)](https://organic-chemistry.org) [organic-chemistry.org]
- To cite this document: BenchChem. [ Technical Support Center: Piperidine N-Alkylation Optimization]. BenchChem, [2026]. [Online PDF]. Available at: [<https://www.benchchem.com/product/b578404/docs#technical-support-center-piperidine-n-alkylation-optimization>]

Disclaimer & Data Validity:

The information provided in this document is for Research Use Only (RUO) and is strictly not intended for diagnostic or therapeutic procedures. While BenchChem strives to provide accurate protocols, we make no warranties, express or implied, regarding the fitness of this product for every specific experimental setup.

Technical Support: The protocols provided are for reference purposes. Unsure if this reagent suits your experiment?

Need Industrial/Bulk Grade? [Request Custom Synthesis Quote](#)

BenchChem

Our mission is to be the trusted global source of essential and advanced chemicals, empowering scientists and researchers to drive progress in science and industry.

Contact

Address: 3281 E Guasti Rd
Ontario, CA 91761, United States
Phone: (601) 213-4426
Email: info@benchchem.com

[Contact our Ph.D. Support Team for a compatibility check](#)