

# Comparative Study of Alkylating Agents for Azetidine Synthesis

**Author:** BenchChem Technical Support Team. **Date:** May 2026

## Compound of Interest

**Compound Name:** 1-Boc-3-iodomethyl-3-methylazetidine

**CAS No.:** 1408074-76-9

**Cat. No.:** B1403465

[Get Quote](#)

## Executive Summary

Azetidines (4-membered nitrogen heterocycles) represent a "Goldilocks" zone in medicinal chemistry: they offer greater metabolic stability than aziridines and distinct vector positioning compared to pyrrolidines.[1] However, their synthesis is thermodynamically disfavored due to significant ring strain (~25.4 kcal/mol).

This guide focuses on the nucleophilic cyclization strategy, where the choice of alkylating agent (electrophile) dictates the reaction kinetics, yield, and impurity profile. We compare three primary classes of alkylating agents: Mixed 1,3-Dihaloalkanes, Symmetric 1,3-Dihaloalkanes, and Sulfonate Esters (derived from Amino Alcohols).

**Key Finding:** While 1,3-dibromopropane offers faster kinetics, 1-bromo-3-chloropropane provides superior process control by minimizing oligomerization through sequential alkylation. For chiral scaffolds, activated amino alcohols (via cyclic sulfates or sulfonates) remain the gold standard despite lower atom economy.

## Mechanistic Underpinnings & Agent Selection

The formation of the azetidine ring via alkylation typically proceeds through an intramolecular reaction.<sup>[2]</sup> The success of this transformation relies on the Thorpe-Ingold Effect (gem-dimethyl effect) and the specific nature of the leaving group (LG).

### The Kinetic Challenge

The rate of cyclization (

) competes with intermolecular polymerization (

).

- High Dilution: Favors cyclization but reduces throughput.
- Leaving Group Ability: A better LG (I > Br > Cl) increases but can also accelerate polymerization if not controlled.

### Decision Matrix: Selecting the Alkylating Agent

Agent Class	Specific Reagent	Mechanism Type	Best For	Primary Drawback
Mixed Dihalo	1-Bromo-3-chloropropane	Sequential Alkylation	Primary Amines, Bulk Synthesis	Slower 2nd step (Cl displacement)
Sym. Dihalo	1,3-Dibromopropane	Simultaneous Activation	Secondary Amines	High oligomerization risk
Sulfonates	Mesyl Chloride /	Intramolecular	Chiral Amino Alcohols	Multi-step; Atom economy
Epoxides	Epichlorohydrin	Ring Opening -> Cyclization	3-Hydroxyazetidines	Regioselectivity issues

## Comparative Performance Analysis

### A. 1-Bromo-3-chloropropane (The "Sequential" Standard)

This reagent exploits the differential reactivity between bromine and chlorine.

- Step 1 (Fast): Intermolecular displacement of Bromine by the amine.
- Step 2 (Slow): Intramolecular displacement of Chlorine (Ring Closure).

Data Profile:

- Typical Yield: 65–85%
- Selectivity: High (favors mono-alkylation first).
- Solvent: Acetonitrile or Toluene.

### B. 1,3-Dibromopropane (The "Hot" Electrophile)

Both ends of the molecule are equally reactive.

- Risk: If a primary amine is used, it can react with two ends of different alkyl chains before closing the ring, leading to "polymer strings."
- Optimization: Requires high dilution (0.05 M) or syringe pump addition.
- Typical Yield: 40–60% (unless optimized).

### C. Activated Amino Alcohols (Sulfonates)

Converting a chiral 1,3-amino alcohol into a leaving group (OMs/OTs) allows for the synthesis of enantiopure azetidines.

- Green Alternative: Cyclic Sulfates. These are generated from 1,3-diols and react with amines to form the ring in one pot with excellent stereoretention.

## Quantitative Comparison Table

Parameter	1-Bromo-3-chloropropane	1,3-Dibromopropane	Amino Alcohol (via Mesylate)
Reaction Kinetics	Biphasic (Fast/Slow)	Fast/Fast	Controlled (Stepwise)
Oligomer Formation	Low (<5%)	High (>15% without dilution)	Negligible
Temp. Requirement	Reflux (80°C+)	RT to 50°C	0°C -> Reflux
Atom Economy	Moderate	Moderate	Low (Stoichiometric sulfonyl waste)
Scalability	High (kg scale)	Medium	Medium

## Visualizing the Reaction Pathways

The following diagram illustrates the competing pathways and the "Sequential Advantage" of using mixed dihalides.

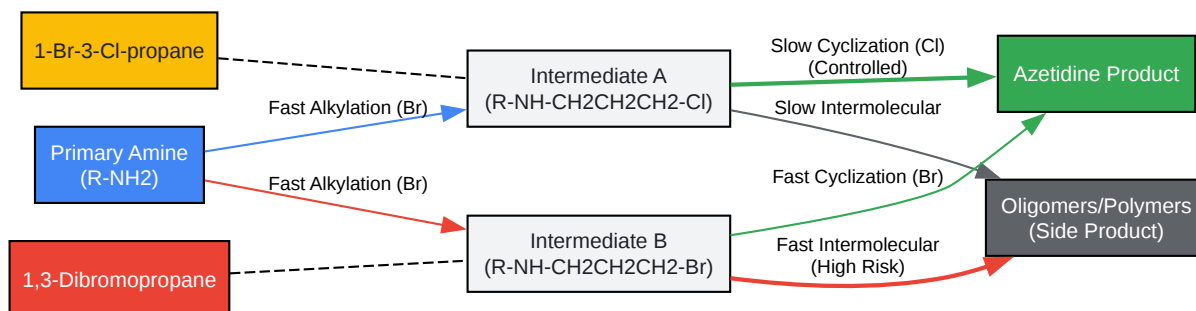

[Click to download full resolution via product page](#)

Caption: Kinetic differentiation between mixed dihalides (top path) and symmetric dihalides (bottom path). The "Slow Cyclization" step in the mixed pathway allows for better thermal control of the ring closure.

## Experimental Protocols

## Protocol A: Synthesis via 1-Bromo-3-chloropropane (Recommended for Scale)

This protocol minimizes dimerization by exploiting the lower reactivity of the chloride leaving group.

Reagents:

- Primary Amine (1.0 equiv)
- 1-Bromo-3-chloropropane (1.1 equiv)
- Base: Potassium Carbonate ( , 3.0 equiv)
- Solvent: Acetonitrile (MeCN) [0.2 M concentration]

Step-by-Step:

- Dissolution: Dissolve the amine and in MeCN.
- Controlled Addition: Add 1-bromo-3-chloropropane dropwise at room temperature (RT) over 30 minutes. Note: The exotherm here is from Br-displacement.
- Intermediate Phase: Stir at RT for 2 hours. TLC should show consumption of starting amine and formation of the mono-alkylated chloro-intermediate.
- Cyclization: Heat the reaction to reflux (80–82°C) for 16–24 hours. This thermal energy is required to drive the displacement of the chloride.
- Workup: Cool to RT. Filter off inorganic salts. Concentrate the filtrate.
- Purification: Acid-base extraction is preferred. Dissolve residue in , extract with 1M HCl. Basify aqueous layer with NaOH to pH 12, extract back into

, dry (  
) , and concentrate.

## Protocol B: Chiral Synthesis via Cyclic Sulfate (Green/High Precision)

Best for synthesizing 2-substituted azetidines from chiral 1,3-diols.

Reagents:

- Chiral 1,3-diol (1.0 equiv)
- Thionyl Chloride (  
, 1.1 equiv) -> followed by Oxidation (  
,  
)
- Primary Amine (1.1 equiv)

Step-by-Step:

- Cyclic Sulfate Formation: Convert the 1,3-diol to the cyclic sulfate using  
then catalytic  
/  
. Isolate the cyclic sulfate (often a crystalline solid).
- Ring Opening: Dissolve cyclic sulfate in THF. Add amine.<sup>[2][3][4][5][6][7]</sup> Stir at RT. The amine attacks the less hindered carbon (regioselective), opening the ring to form the sulfate hemi-ester.
- Cyclization: Hydrolyze the sulfate ester (add 20%  
and heat slightly) or use a base (

in THF) to displace the sulfate group and close the ring.

## Troubleshooting & Optimization

Observation	Root Cause	Corrective Action
Low Yield / Polymer Gum	Concentration too high	Dilute reaction to <0.1 M. Use syringe pump for alkylating agent.
Incomplete Reaction	Chloride LG too slow	Add catalytic Sodium Iodide (Finkelstein condition) to convert -Cl to -I in situ.
Elimination Products (Allylamines)	Base too strong/Temp too high	Switch from to or . Lower temperature.

## References

- Vertex AI Search. (2025). Access to 3-Azetidines via Halogenation of Titanacyclobutanes. National Institutes of Health. [8\[1\]\[7\]\[9\]](#)
- Vertex AI Search. (2023). Azetidine synthesis by La(OTf)<sub>3</sub>-catalyzed intramolecular regioselective aminolysis of cis-3,4-epoxy amines. *Frontiers in Chemistry*. [2\[1\]\[7\]\[9\]](#)
- Vertex AI Search. (2025). A modular synthesis of azetidines from reactive triplet imine intermediates using an intermolecular aza Paternò–Büchi reaction. *Nature Chemistry*. [7\[1\]\[2\]\[6\]\[7\]\[9\]\[10\]\[8\]](#)
- Vertex AI Search. (2021). Recent Advances in the Synthesis and Reactivity of Azetidines: Strain-Driven Character of the Four-Membered Heterocycle. *Royal Society of Chemistry*. [\[3\]\[11\] 1\[1\]\[7\]](#)
- Vertex AI Search. (2021). Intramolecular Ring-Opening Decomposition of Aryl Azetidines. *ACS Medicinal Chemistry Letters*. [12\[1\]\[7\]\[9\]](#)

### Need Custom Synthesis?

BenchChem offers custom synthesis for rare earth carbides and specific isotopic labeling.

Email: [info@benchchem.com](mailto:info@benchchem.com) or [Request Quote Online](#).

## Sources

- [1. pubs.rsc.org \[pubs.rsc.org\]](https://pubs.rsc.org)
- [2. Azetidine synthesis by La\(OTf\)<sub>3</sub>-catalyzed intramolecular regioselective aminolysis of cis-3,4-epoxy amines - PMC \[pmc.ncbi.nlm.nih.gov\]](#)
- [3. Synthesis of azetidines by aza Paternò–Büchi reactions - Chemical Science \(RSC Publishing\) \[pubs.rsc.org\]](#)
- [4. Azetidine synthesis \[organic-chemistry.org\]](https://organic-chemistry.org)
- [5. pnrjournal.com \[pnrjournal.com\]](https://pnrjournal.com)
- [6. Frontiers | Azetidine synthesis by La\(OTf\)<sub>3</sub>-catalyzed intramolecular regioselective aminolysis of cis-3,4-epoxy amines \[frontiersin.org\]](#)
- [7. A modular synthesis of azetidines from reactive triplet imine intermediates using an intermolecular aza Paternò–Büchi reaction - PMC \[pmc.ncbi.nlm.nih.gov\]](#)
- [8. Access to 3-Azetidines via Halogenation of Titanacyclobutanes - PMC \[pmc.ncbi.nlm.nih.gov\]](#)
- [9. researchgate.net \[researchgate.net\]](https://researchgate.net)
- [10. researchgate.net \[researchgate.net\]](https://researchgate.net)
- [11. researchgate.net \[researchgate.net\]](https://researchgate.net)
- [12. Intramolecular Ring-Opening Decomposition of Aryl Azetidines - PMC \[pmc.ncbi.nlm.nih.gov\]](#)
- To cite this document: BenchChem. [Comparative Study of Alkylating Agents for Azetidine Synthesis]. BenchChem, [2026]. [Online PDF]. Available at: [\[https://www.benchchem.com/product/b1403465/docs#comparative-study-of-alkylating-agents-for-azetidine-synthesis\]](https://www.benchchem.com/product/b1403465/docs#comparative-study-of-alkylating-agents-for-azetidine-synthesis)

---

### Disclaimer & Data Validity:

The information provided in this document is for Research Use Only (RUO) and is strictly not intended for diagnostic or therapeutic procedures. While BenchChem strives to provide accurate protocols, we make no warranties, express or implied, regarding the fitness of this product for every specific experimental setup.

**Technical Support:** The protocols provided are for reference purposes. Unsure if this reagent suits your experiment?

**Need Industrial/Bulk Grade?** [Request Custom Synthesis Quote](#)

## BenchChem

Our mission is to be the trusted global source of essential and advanced chemicals, empowering scientists and researchers to drive progress in science and industry.

### Contact

Address: 3281 E Guasti Rd  
Ontario, CA 91761, United States  
Phone: (601) 213-4426  
Email: [info@benchchem.com](mailto:info@benchchem.com)

[Contact our Ph.D. Support Team for a compatibility check](#)