

Application Note: Strategic Isopropylation of Methyl 4-Fluoro-2-Hydroxybenzoate

Author: BenchChem Technical Support Team. **Date:** May 2026

Compound of Interest

Compound Name: *Methyl 4-fluoro-2-isopropoxybenzoate*

Cat. No.: *B14026327*

[Get Quote](#)

Executive Summary & Chemical Context[1][2][3][4][5][6][7][8][9][10]

The O-isopropylation of methyl 4-fluoro-2-hydroxybenzoate (Methyl 4-fluorosalicylate) is a pivotal transformation in the synthesis of active pharmaceutical ingredients (APIs), particularly for modulators of the central nervous system and anti-inflammatory agents.

While theoretically simple, this reaction presents a specific triad of chemoselective challenges:

- **Intramolecular Hydrogen Bonding:** The ortho-phenolic hydroxyl group forms a strong hydrogen bond with the ester carbonyl (interaction energy ~5-7 kcal/mol), significantly reducing the acidity of the phenol and the nucleophilicity of the resulting phenoxide.
- **Steric Impediment:** The isopropyl group is a secondary alkyl center. In nucleophilic substitution (), secondary halides are prone to competing E2 elimination, generating propene rather than the desired ether.

- Ester Stability: The methyl ester is susceptible to hydrolysis (saponification) or transesterification under harsh basic conditions.

This guide provides two validated protocols designed to overcome these barriers, prioritizing yield, purity, and scalability.

Reagent Selection Matrix

The choice of reagent dictates the reaction mechanism and impurity profile. Use the following matrix to select the optimal path for your specific constraints.

Feature	Path A: Williamson Ether Synthesis	Path B: Mitsunobu Coupling
Primary Reagents	2-Iodopropane (or 2-Bromopropane) + Base	Isopropanol + + DIAD/DEAD
Mechanism	Substitution	Redox-Dehydration (inversion)
Key Base	or	None (Betaine intermediate acts as base)
Atom Economy	High	Low (Generates and hydrazine byproduct)
Scalability	Excellent (Kilogram scale)	Moderate (Difficult purification at scale)
Primary Risk	E2 Elimination (Propene formation)	Separation of Triphenylphosphine Oxide
Recommendation	Standard Production	R&D / Small Scale / High Value

Mechanistic Pathways & Decision Logic

The following diagram illustrates the competing pathways and the strategic decision-making process required for this synthesis.

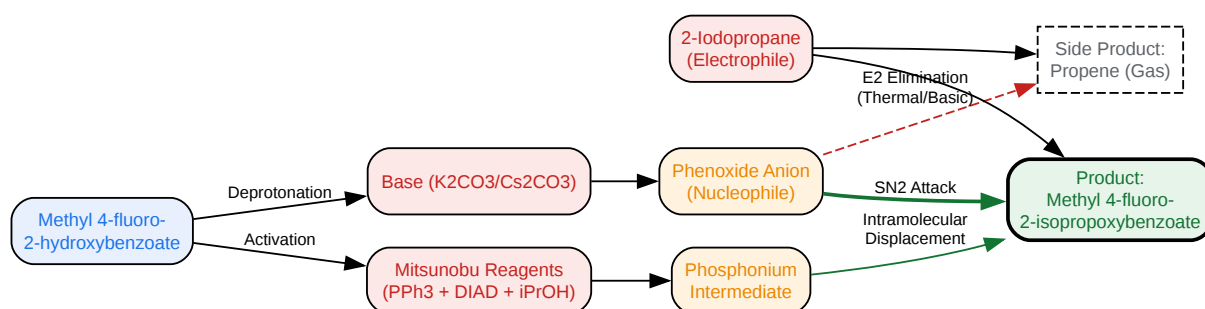

[Click to download full resolution via product page](#)

Caption: Mechanistic bifurcation between Williamson Ether Synthesis (top) and Mitsunobu Coupling (bottom).

Protocol A: Scalable Williamson Ether Synthesis

Best for: Gram-to-Kilogram scale synthesis where cost and purification ease are paramount.

Rationale

Potassium carbonate (

) is used as a mild base to deprotonate the phenol without hydrolyzing the methyl ester. DMF is the solvent of choice; its high dielectric constant dissociates the phenoxide-potassium ion pair, increasing nucleophilicity. 2-Iodopropane is preferred over the bromide for its superior leaving group ability, allowing for lower reaction temperatures that suppress E₂ elimination.

Materials

- Methyl 4-fluoro-2-hydroxybenzoate (1.0 eq)
- 2-Iodopropane (1.5 eq) [Alternative: 2-Bromopropane, requires longer time/higher temp]
- Potassium Carbonate (

), anhydrous, granular (2.0 eq)

- Solvent: N,N-Dimethylformamide (DMF), anhydrous (5 mL per gram of substrate)

Step-by-Step Methodology

- Setup: Flame-dry a round-bottom flask equipped with a magnetic stir bar and a reflux condenser. Flush with Nitrogen () or Argon.
- Dissolution: Charge the flask with Methyl 4-fluoro-2-hydroxybenzoate and anhydrous DMF. Stir until fully dissolved.
- Deprotonation: Add in a single portion. The suspension may turn slightly yellow. Stir at room temperature for 15 minutes to initiate deprotonation and break the intramolecular H-bond.
- Alkylation: Add 2-Iodopropane dropwise via syringe.
 - Critical Control: If using 2-Bromopropane, add sodium iodide (0.1 eq) as a Finkelstein catalyst to accelerate the reaction.
- Reaction: Heat the mixture to 55°C.
 - Note: Do not exceed 65°C. Higher temperatures drastically increase the rate of E2 elimination (propene formation), consuming the alkylating agent.
- Monitoring: Monitor via TLC (Hexanes/EtOAc 4:1) or HPLC.[1] Reaction is typically complete in 4–6 hours.
- Workup:
 - Cool to room temperature.[2][3]
 - Dilute with Ethyl Acetate (EtOAc) and wash with water () to remove DMF.

- Tip: A Lithium Chloride (5% aq) wash helps remove residual DMF more effectively.
- Dry organic layer over

, filter, and concentrate in vacuo.
- Purification: The crude product is often pure enough for subsequent steps. If necessary, purify via silica gel flash chromatography (Gradient: 0-10% EtOAc in Hexanes).

Protocol B: Mitsunobu Coupling (High Precision)

Best for: Small scale, precious substrates, or if elimination is problematic in Protocol A.

Rationale

The Mitsunobu reaction activates the alcohol (isopropanol) rather than the phenol. This avoids the formation of a carbocation or the requirement for high heat, completely eliminating the risk of E2 elimination. It proceeds with inversion of configuration (irrelevant for isopropanol) and forms the ether under neutral conditions.

Materials

- Methyl 4-fluoro-2-hydroxybenzoate (1.0 eq)
- Isopropanol (anhydrous) (1.2 eq)
- Triphenylphosphine (

) (1.5 eq)
- Diisopropyl azodicarboxylate (DIAD) (1.5 eq)
- Solvent: Tetrahydrofuran (THF), anhydrous

Step-by-Step Methodology

- Setup: Use a dry flask under inert atmosphere (

).

- **Mixing:** Dissolve the salicylate substrate, , and Isopropanol in anhydrous THF. Cool the solution to 0°C in an ice bath.
- **Addition:** Add DIAD dropwise over 10–15 minutes.
 - **Visual Cue:** The solution will turn yellow/orange and then fade back to colorless/pale yellow as the DIAD is consumed.
- **Reaction:** Remove the ice bath and allow to stir at room temperature.
- **Monitoring:** Reaction is usually rapid (1–3 hours). Monitor by TLC.[4]
- **Workup:** Concentrate the solvent directly.
- **Purification:** This is the bottleneck. The crude will contain Triphenylphosphine oxide ().
 - **Trituration Method:** Add cold Hexanes/Ether (9:1) to the residue. often precipitates; filter it off.
 - **Chromatography:** Load the filtrate onto a silica column. Elute with Hexanes/EtOAc.

Analytical Quality Control (QC)

Verify the identity of your product using these diagnostic signals.

Technique	Diagnostic Signal	Interpretation
1H NMR	4.5–4.7 ppm (Septet, 1H)	Methine proton of the isopropyl group ().
1H NMR	1.3–1.4 ppm (Doublet, 6H)	Methyl protons of the isopropyl group.
1H NMR	Loss of ~10.5 ppm	Disappearance of the phenolic -OH singlet (H-bonded).
13C NMR	~72 ppm	Carbon of the isopropoxy methine.
IR	Loss of broad band ~3200	Disappearance of O-H stretch.

Troubleshooting Guide

- Issue: Low Conversion (Protocol A).
 - Cause: "Stalling" due to loss of alkyl halide via evaporation or elimination.
 - Fix: Add an additional 0.5 eq of 2-Iodopropane and stir for 2 more hours. Ensure the system is sealed well.
- Issue: Hydrolysis of Ester.
 - Cause: Wet DMF or excessive base heating.
 - Fix: Ensure DMF is anhydrous (store over molecular sieves). Switch to in Acetonitrile (lower boiling point, milder).
- Issue: Product Co-elutes with (Protocol B).

- Fix: Use Polymer-supported

(PS-PPh₃) to allow filtration of the phosphorus byproduct.

References

- Mitsunobu, O. (1981). The Use of Diethyl Azodicarboxylate and Triphenylphosphine in Synthesis and Transformation of Natural Products. *Synthesis*. [Link](#)
- Swamy, K. C. K., et al. (2009). Mitsunobu and Related Reactions: Advances and Applications. *Chemical Reviews*. [Link](#)
- Drauz, K., et al. (2012). Alkylation of Phenols. In *Industrial Organic Chemistry*. Wiley-VCH. (General reference for industrial Williamson synthesis conditions). [Link](#)
- Sigma-Aldrich. (2023).[4] Product Specification: Methyl 4-fluoro-2-hydroxybenzoate. (Substrate properties). [Link](#)

Need Custom Synthesis?

BenchChem offers custom synthesis for rare earth carbides and specific isotopic labeling.

Email: info@benchchem.com or [Request Quote Online](#).

Sources

- [1. A New Alkylation-Elimination Method for Synthesis of Antiviral Fluoromethylenecyclopropane Analogues of Nucleosides - PMC \[pmc.ncbi.nlm.nih.gov\]](#)
- [2. Organic Syntheses Procedure \[orgsyn.org\]](#)
- [3. ijpsonline.com \[ijpsonline.com\]](#)
- [4. preprints.org \[preprints.org\]](#)
- To cite this document: BenchChem. [Application Note: Strategic Isopropylation of Methyl 4-Fluoro-2-Hydroxybenzoate]. BenchChem, [2026]. [Online PDF]. Available at: [<https://www.benchchem.com/product/b14026327/docs#application-note-strategic-isopropylation-of-methyl-4-fluoro-2-hydroxybenzoate>]

Disclaimer & Data Validity:

The information provided in this document is for Research Use Only (RUO) and is strictly not intended for diagnostic or therapeutic procedures. While BenchChem strives to provide accurate protocols, we make no warranties, express or implied, regarding the fitness of this product for every specific experimental setup.

Technical Support: The protocols provided are for reference purposes. Unsure if this reagent suits your experiment?

Need Industrial/Bulk Grade? [Request Custom Synthesis Quote](#)

BenchChem

Our mission is to be the trusted global source of essential and advanced chemicals, empowering scientists and researchers to drive progress in science and industry.

Contact

Address: 3281 E Guasti Rd
Ontario, CA 91761, United States
Phone: (601) 213-4426
Email: info@benchchem.com

[Contact our Ph.D. Support Team for a compatibility check](#)