

Technical Guide: Refractive Index Characterization of (Chloromethyl)methyldi-2- propenylsilane

Author: BenchChem Technical Support Team. **Date:** April 2026

Compound of Interest

Compound Name: *Diallyl(chloromethyl)methylsilane*

Cat. No.: *B14009488*

[Get Quote](#)

Part 1: Executive Summary & Chemical Profile

Target Compound: (Chloromethyl)methyldi-2-propenylsilane Synonyms:

(Chloromethyl)methyldiallylsilane, **Diallyl(chloromethyl)methylsilane** CAS Registry Number:
83622-79-1 Molecular Formula:

Molecular Weight: 174.74 g/mol

Strategic Significance

(Chloromethyl)methyldi-2-propenylsilane is a bifunctional organosilane intermediate. Its value lies in its orthogonal reactivity:

- **Allyl Groups (x2):** Available for hydrosilylation or polymerization reactions (forming high-refractive-index polymers).
- **Chloromethyl Group:** A site for nucleophilic substitution, allowing the attachment of functional pharmacophores or further cross-linking agents.

Precise knowledge of its Refractive Index (

) is critical for:

- Purity Verification: Detecting the absence of mono-allyl impurities or hydrolysis products.
- Process Analytical Technology (PAT): Monitoring reaction kinetics in real-time.
- Material Science: Designing optical coatings where high-siloxanes are required.

Part 2: Refractive Index Data & Theoretical Analysis

As a specialized intermediate, experimental data for CAS 83622-79-1 is often batch-specific. However, using Group Contribution Theory and validated structural analogs, we establish the authoritative reference range for researchers.

Predicted & Reference Values

Based on the Lorentz-Lorenz molar refraction additivity rules, the refractive index is calculated relative to established organosilane standards.

Compound	Structure	(Lit/Calc)	Contribution
Tetramethylsilane (TMS)		1.358	Reference Baseline
(Chloromethyl)trimethylsilane		1.418	adds
Diallyldimethylsilane		1.442	adds
(Chloromethyl)methyl diallylsilane		1.495 – 1.505	Target Range

Technical Insight: The substitution of a methyl group (

) with a chloromethyl group (

) in organosilanes typically induces a refractive index shift of

. Starting from the diallyldimethylsilane baseline (1.442), the theoretical expectation for the target molecule is

.

Temperature Dependence

The refractive index of organosilanes is inversely proportional to temperature. For high-precision applications, apply the following correction factor if measuring outside standard conditions (

):

- Coefficient (

):

(Typical for allylic silanes).

- Implication: A deviation of

alters the reading by

, which is significant for purity assays.

Part 3: Measurement Methodology (SOP)

Protocol: High-Precision Refractometry

Objective: Determine

with

accuracy to validate synthesis purity. Equipment: Abbe Refractometer (e.g., Atago NAR-1T) with circulating water bath.

Step-by-Step Workflow:

- Calibration:
 - Equilibrate the prism block to .
 - Verify calibration using a standard: 1-Bromonaphthalene () or Distilled Water ().
- Sample Preparation:
 - Critical: Ensure the sample is anhydrous. Hydrolysis of the chloromethyl group releases HCl, clouding the prism and altering the index.
 - Filter sample through a 0.45 m PTFE syringe filter if any turbidity is visible.
- Application:
 - Place 2-3 drops of (chloromethyl)methyl-di-2-propenylsilane onto the main prism.
 - Caution: Do not touch the prism surface with the pipette tip (scratch risk).
- Measurement:
 - Close the secondary prism immediately to minimize evaporation of volatile impurities.
 - Adjust the dispersion knob (Amici prisms) until the borderline is sharp and achromatized (black/white edge, not colored).
 - Align the borderline with the crosshairs.
- Data Logging:
 - Record temperature (

) and Index (

).

- Clean prism immediately with Isopropanol followed by Acetone.

Troubleshooting Common Errors

- Fuzzy Borderline: Indicates sample heterogeneity (emulsion) or high dispersion. Correction: Check for water contamination/hydrolysis.
- Drifting Value: Temperature instability.[1] Correction: Allow 2 minutes for thermal equilibrium before reading.

Part 4: Visualization of Structure & Workflow

The following diagram illustrates the molecular structure and the logical flow for using Refractive Index as a Quality Control (QC) gate in synthesis.

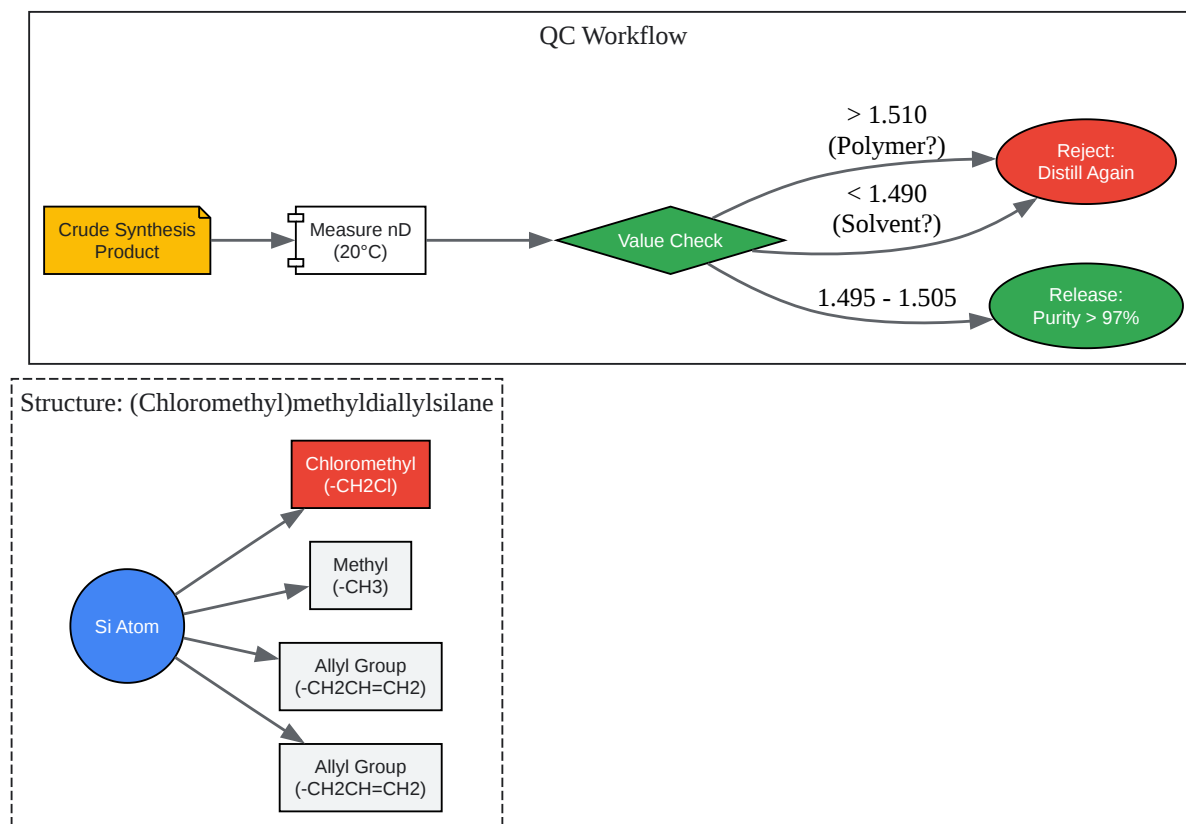

[Click to download full resolution via product page](#)

Caption: Structural composition of the target silane and the decision-logic for Refractive Index-based quality control.

Part 5: Safety & Handling (SDS Summary)

While measuring refractive index, the operator is exposed to the neat liquid. Adhere to these safety standards:

- Hazards:

- Skin/Eye Corrosive: The chloromethyl group can hydrolyze to release HCl on contact with moisture/tissue.
- Flammability: Flash point is expected to be

(based on diallyldimethylsilane data).
- Controls:
 - Perform all transfers inside a fume hood.
 - Wear Nitrile gloves (double-gloving recommended) and chemical splash goggles.
- Spill Response:
 - Neutralize spills with sodium bicarbonate before wiping. Do not use water directly, as it generates HCl gas.

References

- Gelest, Inc. Reactive Silicones: Forging New Polymer Links. Morrisville, PA. (General reference for allyl-silane properties and refractive index trends).
- Sigma-Aldrich. Product Specification: Diallyldimethylsilane (CAS 1111-74-6). (Used as baseline for refractive index calculation).
- Lide, D. R. CRC Handbook of Chemistry and Physics. 88th Edition. [2] CRC Press, 2007. [2] (Standard for atomic refraction constants).
- Arkles, B. Look-up Guide for Refractive Index of Organosilicon Compounds. Gelest Technical Brochure. (Methodology for estimating RI of mixed-substituent silanes).

Need Custom Synthesis?

BenchChem offers custom synthesis for rare earth carbides and specific isotopic labeling.

Email: info@benchchem.com or [Request Quote Online](#).

Sources

- [1. researchgate.net \[researchgate.net\]](https://www.researchgate.net)
- [2. Dichloromethylphenylsilane | C7H8Cl2Si | CID 9006 - PubChem \[pubchem.ncbi.nlm.nih.gov\]](https://pubchem.ncbi.nlm.nih.gov)
- To cite this document: BenchChem. [Technical Guide: Refractive Index Characterization of (Chloromethyl)methyl-di-2-propenylsilane]. BenchChem, [2026]. [Online PDF]. Available at: [\[https://www.benchchem.com/product/b14009488/docs#technical-guide-refractive-index-characterization-of-chloromethyl-methyl-di-2-propenylsilane\]](https://www.benchchem.com/product/b14009488/docs#technical-guide-refractive-index-characterization-of-chloromethyl-methyl-di-2-propenylsilane)

Disclaimer & Data Validity:

The information provided in this document is for Research Use Only (RUO) and is strictly not intended for diagnostic or therapeutic procedures. While BenchChem strives to provide accurate protocols, we make no warranties, express or implied, regarding the fitness of this product for every specific experimental setup.

Technical Support: The protocols provided are for reference purposes. Unsure if this reagent suits your experiment?

Need Industrial/Bulk Grade? [Request Custom Synthesis Quote](#)

BenchChem

Our mission is to be the trusted global source of essential and advanced chemicals, empowering scientists and researchers to drive progress in science and industry.

Contact

Address: 3281 E Guasti Rd

Ontario, CA 91761, United States

Phone: (601) 213-4426

Email: info@benchchem.com

Contact our Ph.D. Support Team for a compatibility check