

Comparative Guide: Metabolic Stability of Fluorinated vs. Non-Fluorinated Amines

Author: BenchChem Technical Support Team. **Date:** April 2026

Compound of Interest

Compound Name: 3,3-Difluoro-N-(propan-2-yl)cyclobutan-1-amine
CAS No.: 1873960-54-3
Cat. No.: B1400612

[Get Quote](#)

Executive Summary

Impact: Fluorination of amine pharmacophores is a cornerstone strategy in medicinal chemistry to extend half-life (

) and reduce intrinsic clearance (

). The Shift: Replacing C-H bonds with C-F bonds adjacent to nitrogen atoms transforms "metabolic liabilities" into stable, orally bioavailable drugs. Key Outcome: Strategic fluorination typically lowers amine

by 1–3 units, reducing lysosomal trapping and phospholipidosis risk while sterically and electronically blocking Cytochrome P450 (CYP) mediated oxidation.

Part 1: Mechanistic Rationale

To engineer stability, one must understand the failure modes of non-fluorinated amines.

The Metabolic Liability of Amines

Non-fluorinated aliphatic amines (e.g., piperidines, pyrrolidines) are prone to rapid oxidative clearance via two primary CYP450 pathways:

- **-Carbon Hydroxylation:** The CYP heme iron abstracts a hydrogen atom from the carbon to the nitrogen. This forms an unstable carbinolamine intermediate, which collapses to release the amine (N-dealkylation).
- **N-Oxidation:** Direct oxidation of the nitrogen lone pair.

The Fluorine Advantage

Fluorine acts as a "metabolic armor" through three distinct physical-organic mechanisms:

- **Electronic Deactivation (The Inductive Effect):** Fluorine is the most electronegative element (). When placed to a nitrogen (e.g., -fluoroamine), it pulls electron density through the -framework. This lowers the electron density of the C-H bonds to the nitrogen, raising the activation energy required for CYP450 to abstract a hydrogen.
- **Modulation:**
 - **Non-Fluorinated:** Typical secondary amines have a . They are fully protonated at physiological pH, leading to high affinity for acidic compartments (lysosomes) and promiscuous binding (high), often correlating with phospholipidosis.
 - **Fluorinated:** -fluorination lowers the by ~1.5 units;

-difluorination by ~3 units. This increases the fraction of uncharged species at pH 7.4, improving membrane permeability and reducing non-specific clearance.

- **Steric & Bond Strength Blockade:** The C-F bond (116 kcal/mol) is significantly stronger than the C-H bond (99 kcal/mol) and chemically inert to CYP oxidation. Placing fluorine directly at a "soft spot" (e.g., 4-position of piperidine) physically blocks the enzyme's access.

Mechanism Visualization

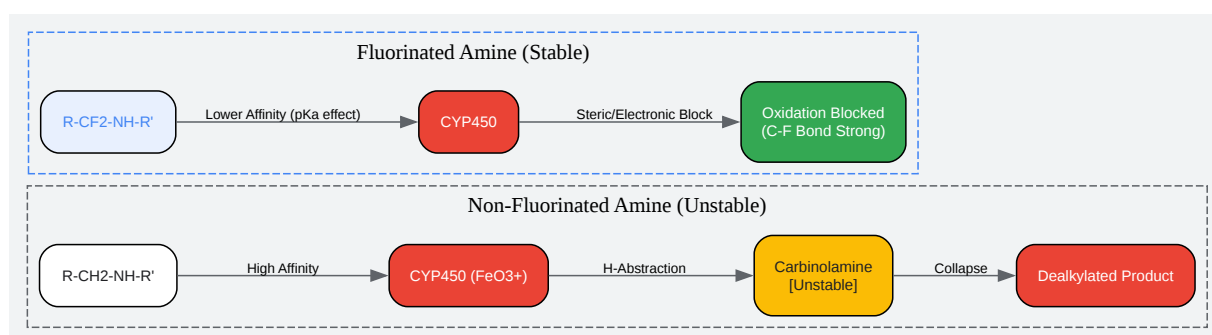

[Click to download full resolution via product page](#)

Caption: Comparison of CYP450-mediated oxidative clearance pathways. Top: Non-fluorinated amines undergo H-abstraction. Bottom: Fluorine substitution prevents abstraction and modulates enzyme affinity.

Part 2: Comparative Performance Analysis

The following data summarizes the impact of fluorination on metabolic stability (

) and basicity (

).

Table 1: Structural Activity Relationship (SAR) – Piperidine Series

Data synthesized from representative medicinal chemistry literature (e.g., Meanwell, 2018).

Compound Structure	Substitution Pattern	(approx)	Relative Metabolic Stability	Mechanism of Improvement
Piperidine	Unsubstituted	~11.0	Low (Baseline)	N/A (Highly vulnerable to oxidation)
4-Fluoropiperidine	Monofluorine ()	~10.0	Moderate (2-5x improvement)	Blocks C4 oxidation; slight reduction.
4,4-Difluoropiperidine	Gem-difluoro ()	~9.0	High (>10x improvement)	Blocks C4 oxidation completely; lowers lipophilicity ().
3,3-Difluoropiperidine	Gem-difluoro ()	~8.5	Very High	Strong inductive effect protects -C-H; significant drop reduces lysosomal trapping.
N-Trifluoroethyl	N-Fluoroalkyl	~5.5	Ultra High	Electron-deficient nitrogen resists oxidation; prevents N-dealkylation.

Case Study: N-Dealkylation Protection

In the optimization of Cathepsin K inhibitors, replacing a standard N-ethyl group with an N-trifluoroethyl (TFE) group resulted in:

- Shift: From 10.2
6.4.
- Metabolic Stability: Human Liver Microsome (HLM) clearance reduced from >100
L/min/mg to <10
L/min/mg.
- Bioavailability: Oral bioavailability () increased from <5% to >60% in rat models.

Part 3: Experimental Protocol

To validate these improvements in your own pipeline, use the standard Microsomal Stability Assay.

Protocol: In Vitro Microsomal Stability (HLM/RLM)

Objective: Determine the Intrinsic Clearance (

) and Half-life (

) of fluorinated vs. non-fluorinated analogs.

Reagents

- Liver Microsomes: Human (HLM) or Rat (RLM) at 20 mg/mL protein conc.
- Buffer: 100 mM Potassium Phosphate (pH 7.4).
- Cofactor: NADPH Regenerating System (or 10 mM NADPH solution).
- Test Compounds: 10 mM DMSO stocks.
- Quench Solution: Acetonitrile (ACN) containing Internal Standard (e.g., Tolbutamide).

Step-by-Step Workflow

- Preparation: Dilute microsomes to 0.5 mg/mL in Phosphate Buffer.
- Pre-Incubation: Add test compound (final conc. 1 M, <0.1% DMSO). Incubate at 37°C for 5 minutes.
- Initiation: Add NADPH (final conc. 1 mM) to start the reaction.
- Sampling: At min, remove 50 L aliquots.
- Quenching: Immediately transfer aliquot into 150 L ice-cold Quench Solution. Vortex.
- Processing: Centrifuge at 4,000 rpm for 15 min to pellet proteins.
- Analysis: Inject supernatant into LC-MS/MS (MRM mode).

Calculation

Plot

vs. Time. The slope is

.

Workflow Visualization

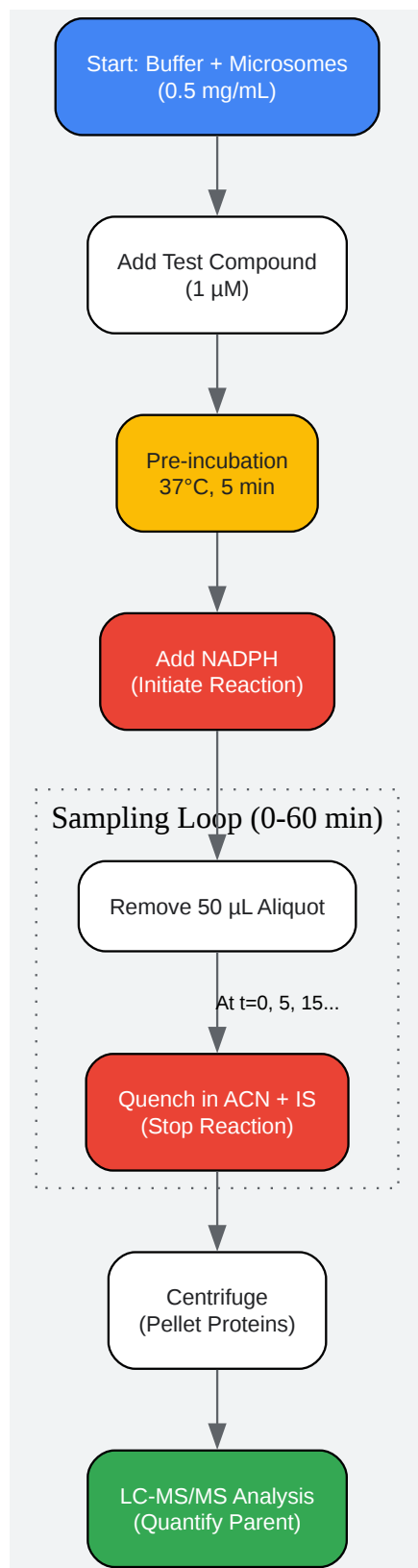

[Click to download full resolution via product page](#)

Caption: Standard operating procedure for determining metabolic stability using liver microsomes.[1]

References

- Meanwell, N. A. (2018). Fluorine in Medicinal Chemistry.[2][3][4][5][6][7] Journal of Medicinal Chemistry, 61(14), 5822–5880. [Link](#)
- Purser, S., Moore, P. R., Swallow, S., & Gouverneur, V. (2008). Fluorine in medicinal chemistry.[2][3][4][5][6][7][8] Chemical Society Reviews, 37(2), 320-330. [Link](#)
- Gillis, E. P., et al. (2015).[9] Applications of Fluorine in Medicinal Chemistry.[2][3][4][5][6][7][10][11] Journal of Medicinal Chemistry, 58(21), 8315–8359. [Link](#)
- Müller, K., Faeh, C., & Diederich, F. (2007). Fluorine in Pharmaceuticals: Looking Beyond Intuition. Science, 317(5846), 1881-1886. [Link](#)

Need Custom Synthesis?

BenchChem offers custom synthesis for rare earth carbides and specific isotopic labeling.

Email: info@benchchem.com or [Request Quote Online](#).

Sources

- 1. [Microsomal Clearance/Stability Assay | Domainex \[domainex.co.uk\]](#)
- 2. [blumberginstitute.org \[blumberginstitute.org\]](#)
- 3. [researchgate.net \[researchgate.net\]](#)
- 4. [pharmacyjournal.org \[pharmacyjournal.org\]](#)
- 5. [chemrxiv.org \[chemrxiv.org\]](#)
- 6. [Metabolic Stability of Fluorinated Small Molecules: A Physical Organic Chemistry Perspective - PubMed \[pubmed.ncbi.nlm.nih.gov\]](#)
- 7. [chemrxiv.org \[chemrxiv.org\]](#)
- 8. [Synthesis and Biological Characterization of 4,4-Difluoro-3-\(phenoxymethyl\)piperidine Scaffold as Dopamine 4 Receptor \(D4R\) Antagonist in vitro Tool compounds - PMC](#)

[\[pmc.ncbi.nlm.nih.gov\]](https://pubmed.ncbi.nlm.nih.gov/)

- [9. Methods to Increase the Metabolic Stability of 18F-Radiotracers \[mdpi.com\]](#)
- [10. tandfonline.com \[tandfonline.com\]](#)
- [11. Comparative Analysis of the Structure and Pharmacological Properties of Some Piperidines and Host–Guest Complexes of \$\beta\$ -Cyclodextrin | MDPI \[mdpi.com\]](#)
- To cite this document: BenchChem. [Comparative Guide: Metabolic Stability of Fluorinated vs. Non-Fluorinated Amines]. BenchChem, [2026]. [Online PDF]. Available at: [\[https://www.benchchem.com/product/b1400612/docs#comparative-guide-metabolic-stability-of-fluorinated-vs-non-fluorinated-amines\]](https://www.benchchem.com/product/b1400612/docs#comparative-guide-metabolic-stability-of-fluorinated-vs-non-fluorinated-amines)

Disclaimer & Data Validity:

The information provided in this document is for Research Use Only (RUO) and is strictly not intended for diagnostic or therapeutic procedures. While BenchChem strives to provide accurate protocols, we make no warranties, express or implied, regarding the fitness of this product for every specific experimental setup.

Technical Support: The protocols provided are for reference purposes. Unsure if this reagent suits your experiment?

Need Industrial/Bulk Grade? [Request Custom Synthesis Quote](#)

BenchChem

Our mission is to be the trusted global source of essential and advanced chemicals, empowering scientists and researchers to drive progress in science and industry.

Contact

Address: 3281 E Guasti Rd

Ontario, CA 91761, United States

Phone: (601) 213-4426

Email: info@benchchem.com

Contact our Ph.D. Support Team for a compatibility check