

Validating the Biological Activity of Synthesized Tetrahydropyrimidines: A Comparative Guide

Author: BenchChem Technical Support Team. **Date:** May 2026

Compound of Interest

Compound Name:	2-Amino-1,4,5,6-tetrahydropyrimidine Hydrochloride
CAS No.:	26893-39-0
Cat. No.:	B140947

[Get Quote](#)

For Researchers, Scientists, and Drug Development Professionals

This guide provides a comparative overview of the biological activities of various synthesized tetrahydropyrimidine (THPM) derivatives. It is designed to assist researchers in validating the biological activity of their own synthesized compounds by offering a compilation of experimental data from published studies, detailed methodologies for key biological assays, and visualizations of relevant signaling pathways.

I. Comparison of Biological Activities

Tetrahydropyrimidines are a class of heterocyclic compounds that have garnered significant interest in medicinal chemistry due to their broad spectrum of biological activities. This section summarizes the quantitative data from various studies, showcasing the potential of THPMs as antimicrobial, anticancer, α -glucosidase inhibitory, and anti-HIV agents.

Table 1: Antimicrobial Activity of Tetrahydropyrimidine Derivatives

The antimicrobial efficacy of THPMs is typically evaluated by determining the Minimum Inhibitory Concentration (MIC), which is the lowest concentration of a compound that prevents visible growth of a microorganism.

Compound ID	Test Organism	MIC ($\mu\text{g/mL}$)	Reference
Series 1	Staphylococcus aureus	1.56 - 12.5	[1]
Bacillus subtilis	1.56 - >50	[1]	
Escherichia coli	3.12 - 25	[1]	
Series 2	Staphylococcus aureus	128	[1]
Pseudomonas aeruginosa	128	[1]	
Candida albicans	32 - 128	[1]	
Aspergillus niger	32 - 128	[1]	
Series 3	Staphylococcus aureus	21.7 - 40.6	[2]
Escherichia coli	17.8 - 101.4	[2]	
Compound 4e, 4f, 4k	Trichophyton mentagrophytes	200	[3]
Compound 8, 10	Various Bacteria	Good to significant activity	[4]

Note: MIC values can vary depending on the specific derivative and the microbial strain tested.

Table 2: Cytotoxic Activity of Tetrahydropyrimidine Derivatives Against Cancer Cell Lines

The anticancer potential of THPMs is often assessed by determining the half-maximal inhibitory concentration (IC50) against various cancer cell lines. A lower IC50 value indicates greater potency.

Compound ID	Cancer Cell Line	IC50 (μM)	Reference
Compound 4b	HeLa	52.59	[5]
Compound 4k	HeLa	43.63	[5]
Compound 4a, 4b, 4h, 4j	K562	67.97 - 79.94	
Compound 4k	MDA-MB-231	74.12	
Compound 4c	MCF-7	45-80 $\mu\text{g}/\text{mL}$	[2]
Compound 4e	HeLa	15-100 $\mu\text{g}/\text{mL}$	[2]
Compound 4j	MCF-7	45-80 $\mu\text{g}/\text{mL}$	[2]
Compound 4k	MCF-7	45-80 $\mu\text{g}/\text{mL}$	[2]

Table 3: α -Glucosidase Inhibitory Activity of Tetrahydropyrimidine Derivatives

Certain THPMs have shown promise as α -glucosidase inhibitors, which is a therapeutic target for type 2 diabetes.

Compound ID	α -Glucosidase Inhibition	IC50 (μM)	Reference
Compound 4g	Stronger than acarbose	Not specified	[5]
Compound 4a, 4b, 4i	Similar to acarbose	Not specified	[5]

Table 4: Anti-HIV Activity of Tetrahydropyrimidine Derivatives

Some THPM derivatives have been investigated for their ability to inhibit the replication of the Human Immunodeficiency Virus (HIV).

Compound ID	Anti-HIV-1 Activity (% Inhibition at 100 μ M)	Reference
Compound 4a	61.43	[2]
Compound 4l	71.65	[2]

II. Experimental Protocols

This section provides detailed methodologies for the synthesis of tetrahydropyrimidines and the key biological assays cited in this guide.

Synthesis of Tetrahydropyrimidines via the Biginelli Reaction

The Biginelli reaction is a one-pot, three-component reaction widely used for the synthesis of dihydropyrimidinones and their derivatives, including tetrahydropyrimidines.[4][6][7]

General Procedure:

- A mixture of an aldehyde (1 mmol), a β -ketoester (e.g., ethyl acetoacetate, 1 mmol), and urea or thiourea (1.5 mmol) is prepared.[4]
- A catalytic amount of an acid (e.g., HCl, p-toluenesulfonic acid) is added to the mixture.[4][6]
- The reaction mixture is typically refluxed in a suitable solvent (e.g., ethanol) for several hours.[4]
- The progress of the reaction is monitored by thin-layer chromatography (TLC).
- Upon completion, the reaction mixture is cooled, and the product is isolated by filtration.
- The crude product is then purified by recrystallization from an appropriate solvent.

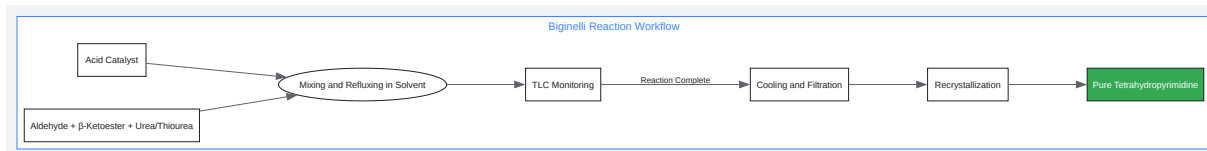

[Click to download full resolution via product page](#)

Biginelli Reaction Workflow

Antimicrobial Activity Assay: Broth Microdilution Method for MIC Determination

This method is used to determine the minimum inhibitory concentration (MIC) of a substance against a specific microorganism.^{[8][9][10][11]}

Procedure:

- Preparation of Compound Dilutions: A serial two-fold dilution of the test compound is prepared in a suitable broth medium in a 96-well microtiter plate.
- Inoculum Preparation: A standardized suspension of the test microorganism (e.g., adjusted to 0.5 McFarland standard) is prepared.
- Inoculation: Each well of the microtiter plate is inoculated with the microbial suspension.
- Controls: Positive (broth with inoculum, no compound) and negative (broth only) controls are included.
- Incubation: The plate is incubated at an appropriate temperature (e.g., 37°C) for 16-20 hours.

- Reading Results: The MIC is determined as the lowest concentration of the compound at which there is no visible growth (turbidity) of the microorganism.

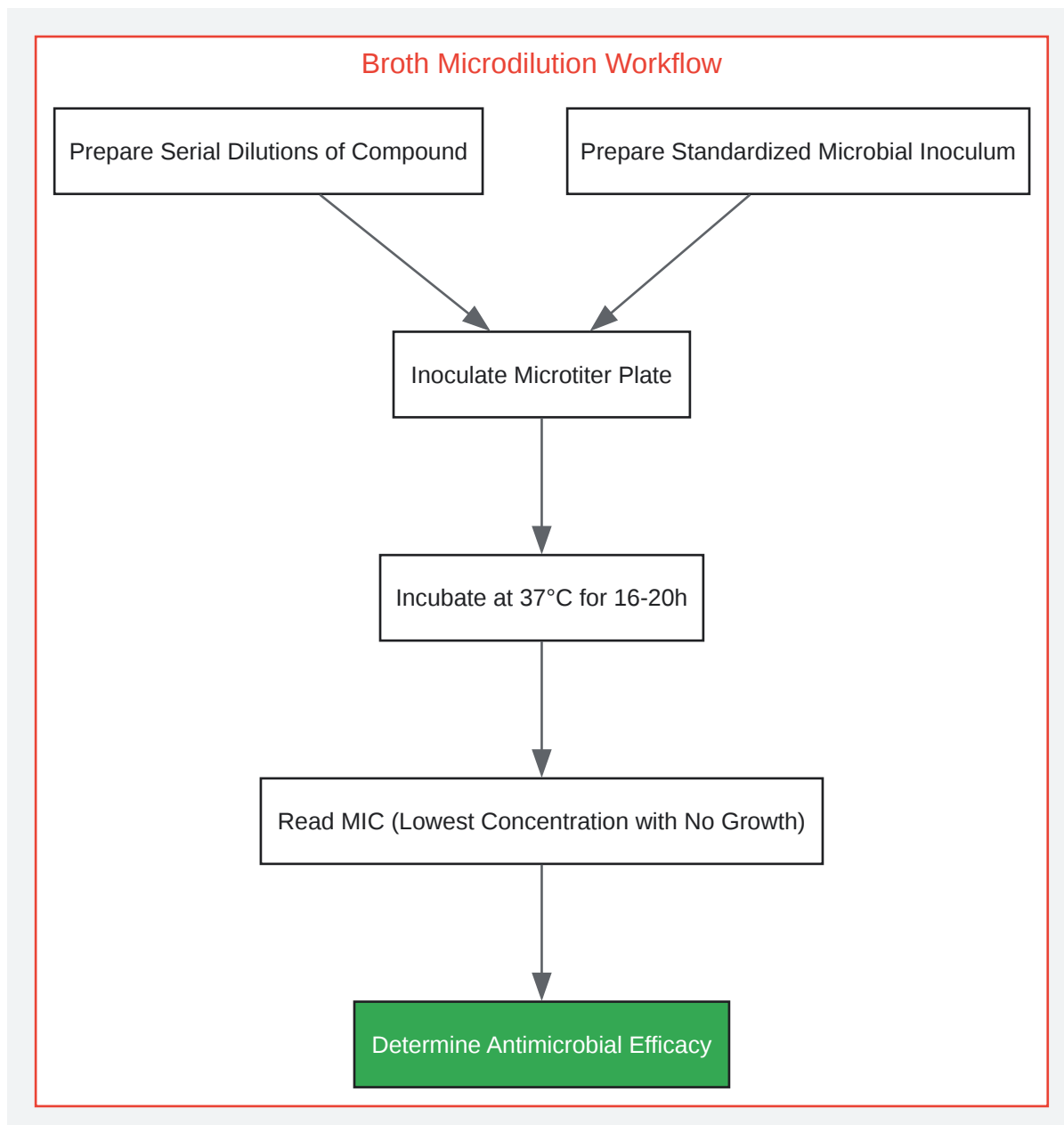

[Click to download full resolution via product page](#)

Broth Microdilution Workflow

Cytotoxicity Assay: MTT Assay

The MTT assay is a colorimetric assay used to assess cell metabolic activity, which serves as an indicator of cell viability, proliferation, and cytotoxicity.^{[12][13][14][15]}

Procedure:

- **Cell Seeding:** Cells are seeded into a 96-well plate at a specific density and allowed to adhere overnight.
- **Compound Treatment:** The cells are treated with various concentrations of the test compound and incubated for a specified period (e.g., 24, 48, or 72 hours).
- **MTT Addition:** MTT (3-(4,5-dimethylthiazol-2-yl)-2,5-diphenyltetrazolium bromide) solution is added to each well and incubated for 2-4 hours. Metabolically active cells reduce the yellow MTT to purple formazan crystals.
- **Solubilization:** A solubilizing agent (e.g., DMSO, isopropanol) is added to dissolve the formazan crystals.
- **Absorbance Measurement:** The absorbance is measured at a wavelength of 570 nm using a microplate reader.
- **Data Analysis:** The percentage of cell viability is calculated relative to untreated control cells, and the IC50 value is determined.

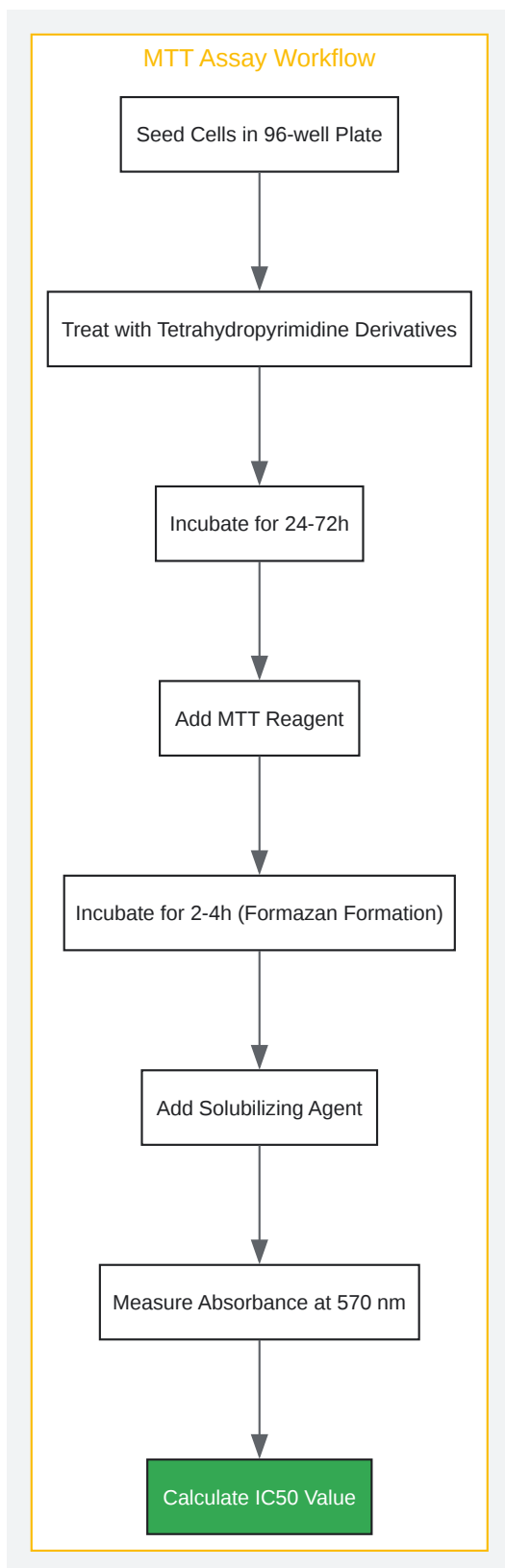

[Click to download full resolution via product page](#)

MTT Assay Workflow

α -Glucosidase Inhibitory Assay

This assay is used to screen for compounds that inhibit the activity of α -glucosidase, an enzyme involved in carbohydrate digestion.[\[16\]](#)[\[17\]](#)

Procedure:

- **Reaction Mixture:** A reaction mixture is prepared containing the α -glucosidase enzyme, a buffer solution (e.g., phosphate buffer, pH 6.8), and the test compound at various concentrations.
- **Pre-incubation:** The mixture is pre-incubated for a short period (e.g., 10 minutes) at 37°C.
- **Substrate Addition:** The substrate, p-nitrophenyl- α -D-glucopyranoside (pNPG), is added to initiate the reaction.
- **Incubation:** The reaction is incubated for a specific time (e.g., 20 minutes) at 37°C. The enzyme hydrolyzes pNPG to p-nitrophenol, which is a yellow-colored product.
- **Stopping the Reaction:** The reaction is stopped by adding a solution of sodium carbonate.
- **Absorbance Measurement:** The absorbance of the p-nitrophenol produced is measured at 405 nm.
- **Data Analysis:** The percentage of inhibition is calculated, and the IC50 value is determined. Acarbose is commonly used as a positive control.

Anti-HIV-1 Assay

This assay evaluates the ability of a compound to inhibit the replication of HIV-1 in cell culture.[\[2\]](#)[\[18\]](#)

Procedure:

- **Cell Culture:** A suitable cell line (e.g., HEK293T) is cultured and seeded in a multi-well plate.
- **Transfection:** The cells are co-transfected with an HIV-1 proviral DNA plasmid and a reporter plasmid (e.g., expressing luciferase).

- **Compound Treatment:** The transfected cells are treated with different concentrations of the test compound.
- **Incubation:** The cells are incubated for a period (e.g., 48 hours) to allow for viral replication.
- **Lysis and Reporter Assay:** The cells are lysed, and the activity of the reporter enzyme (e.g., luciferase) is measured. A decrease in reporter activity indicates inhibition of viral replication.
- **Data Analysis:** The percentage of inhibition is calculated, and the IC50 value is determined.

III. Signaling Pathways Modulated by Tetrahydropyrimidines

Tetrahydropyrimidines exert their biological effects by interacting with various cellular targets and signaling pathways. This section provides a visual representation of some of the key pathways modulated by these compounds.

Inhibition of Mitotic Kinesin Eg5

Monastrol, a well-studied tetrahydropyrimidine, is a specific and allosteric inhibitor of Eg5, a motor protein essential for the formation of the bipolar spindle during mitosis.^{[8][10][12][16]} Inhibition of Eg5 leads to mitotic arrest and subsequent apoptosis in cancer cells.

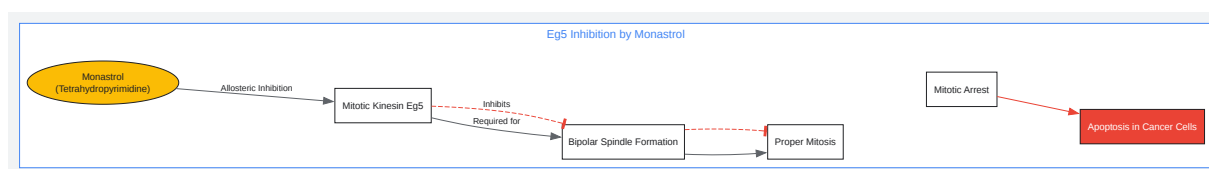

[Click to download full resolution via product page](#)

Eg5 Inhibition by Monastrol

Blockade of L-type Calcium Channels

Certain tetrahydropyrimidine derivatives have been identified as L-type calcium channel blockers.[2][5][13][19] By blocking the influx of calcium ions into vascular smooth muscle cells, these compounds can induce vasodilation, making them potential therapeutic agents for conditions like hypertension.

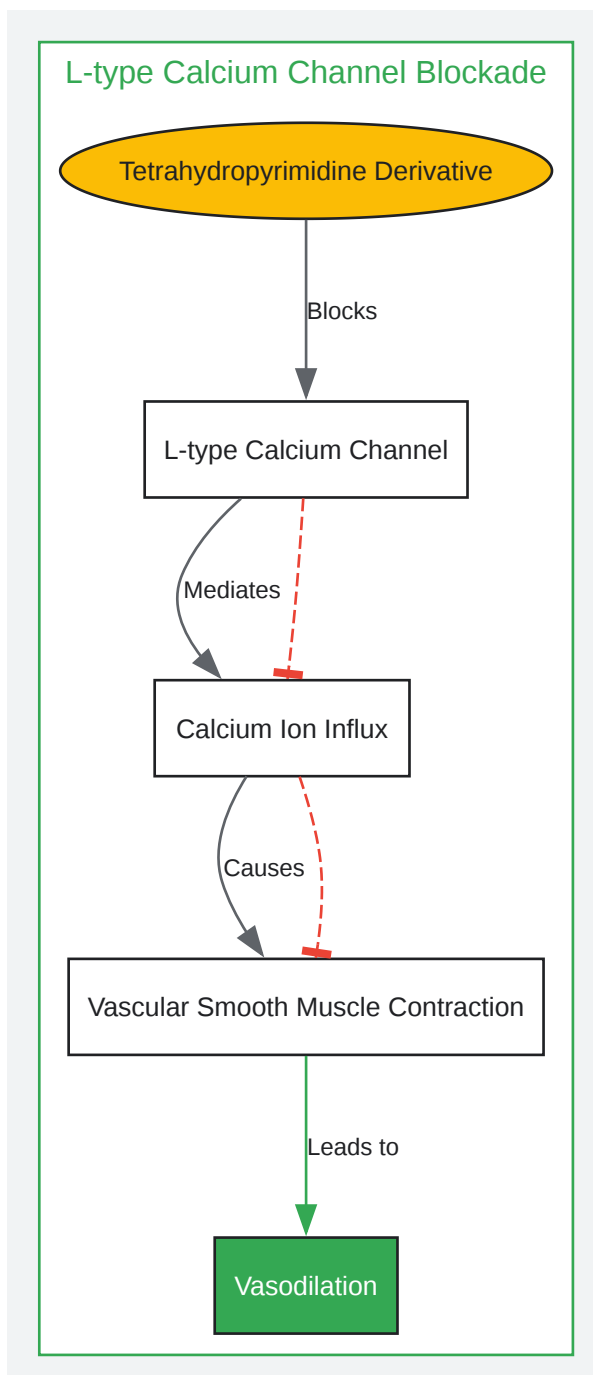

[Click to download full resolution via product page](#)

L-type Calcium Channel Blockade

Modulation of the Hedgehog Signaling Pathway

The Hedgehog (Hh) signaling pathway plays a crucial role in embryonic development and has been implicated in the development of several cancers.^{[4][14][15][18]} While the direct interaction of most tetrahydropyrimidines with this pathway is still under investigation, some small molecule inhibitors targeting components of the Hh pathway, such as Smoothed (SMO), share structural similarities with heterocyclic compounds.

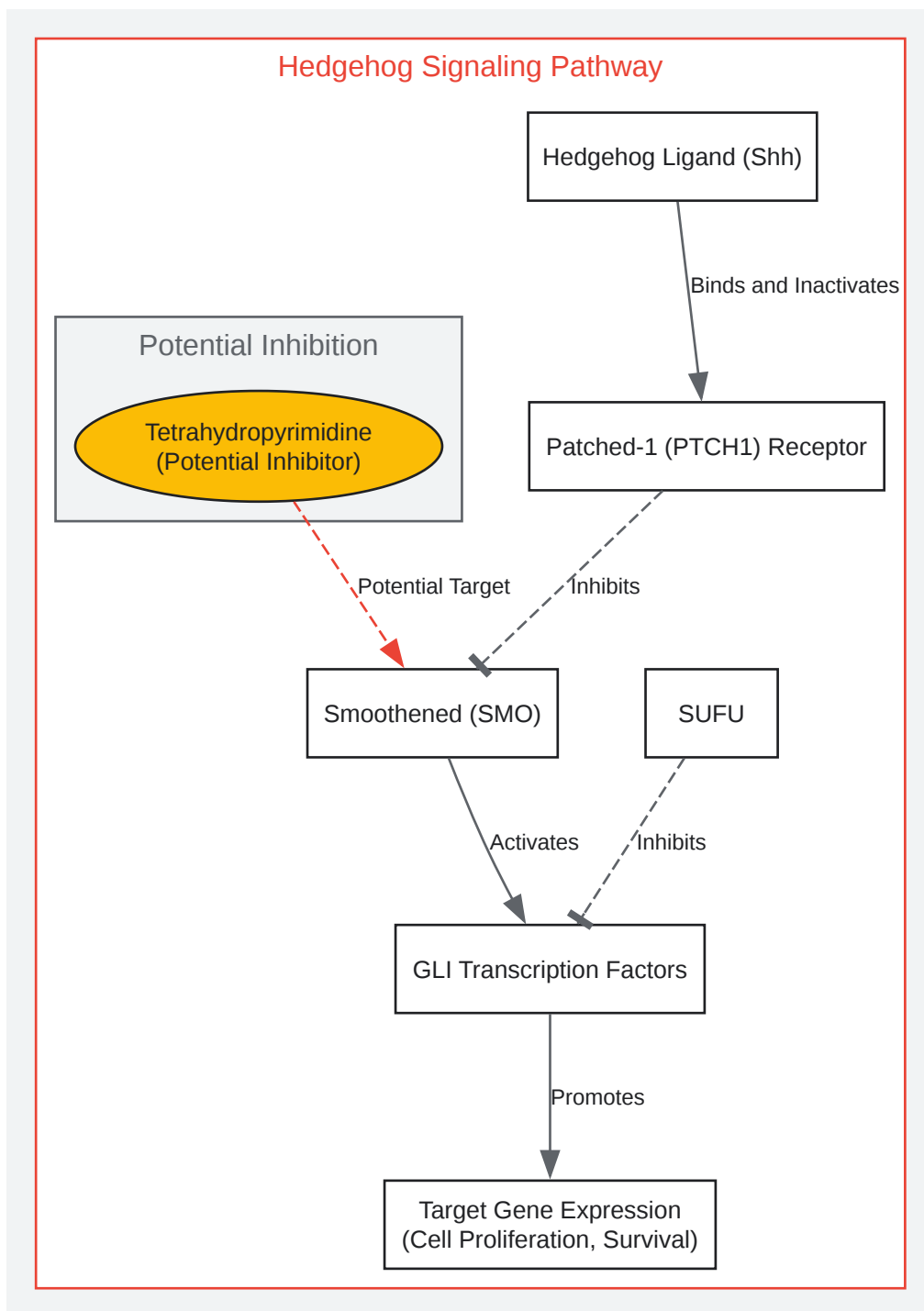

[Click to download full resolution via product page](#)

Hedgehog Signaling Pathway

Agonism of Nicotinic Acetylcholine Receptors

Some tetrahydropyrimidine derivatives have been shown to act as agonists of nicotinic acetylcholine receptors (nAChRs).^{[17][20][21][22]} These receptors are ligand-gated ion channels that play a role in various physiological processes in the central and peripheral nervous systems.

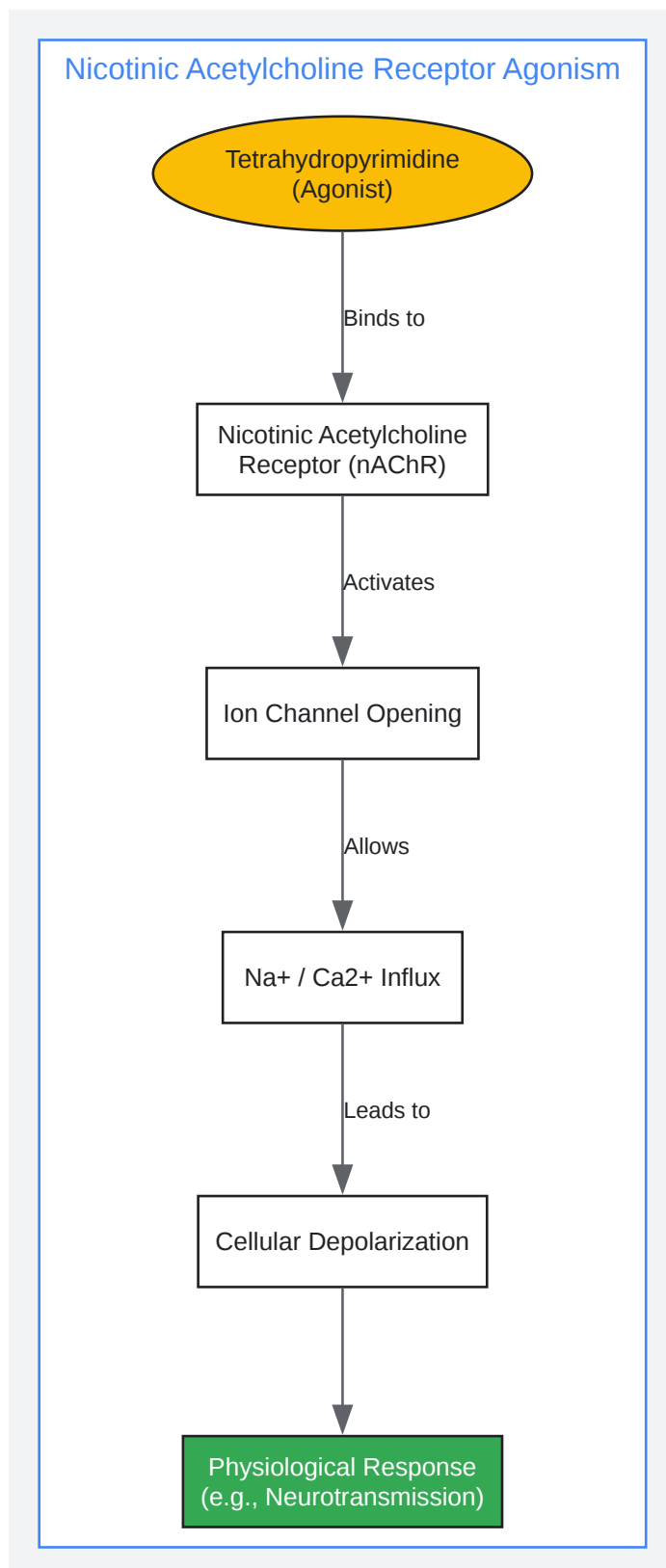

[Click to download full resolution via product page](#)

Nicotinic Receptor Agonism

Need Custom Synthesis?

BenchChem offers custom synthesis for rare earth carbides and specific isotopic labeling.

Email: info@benchchem.com or [Request Quote Online](#).

References

- [1. researchgate.net \[researchgate.net\]](https://www.researchgate.net)
- [2. alliedacademies.org \[alliedacademies.org\]](https://www.alliedacademies.org)
- [3. Recent findings and future directions for interpolar mitotic kinesin inhibitors in cancer therapy - PMC \[pmc.ncbi.nlm.nih.gov\]](#)
- [4. The Utility of Hedgehog Signaling Pathway Inhibition for Cancer - PMC \[pmc.ncbi.nlm.nih.gov\]](#)
- [5. Dihydropyrimidine calcium channel blockers. 4. Basic 3-substituted-4-aryl-1,4-dihydropyrimidine-5-carboxylic acid esters. Potent antihypertensive agents - PubMed \[pubmed.ncbi.nlm.nih.gov\]](#)
- [6. researchgate.net \[researchgate.net\]](https://www.researchgate.net)
- [7. biorxiv.org \[biorxiv.org\]](https://www.biorxiv.org)
- [8. Evidence that monastrol is an allosteric inhibitor of the mitotic kinesin Eg5 - PubMed \[pubmed.ncbi.nlm.nih.gov\]](#)
- [9. selleckchem.com \[selleckchem.com\]](https://www.selleckchem.com)
- [10. Small-molecule and mutational analysis of allosteric Eg5 inhibition by monastrol - PMC \[pmc.ncbi.nlm.nih.gov\]](#)
- [11. Eg5 inhibitor YL001 induces mitotic arrest and inhibits tumor proliferation - PMC \[pmc.ncbi.nlm.nih.gov\]](#)
- [12. Probing Spindle Assembly Mechanisms with Monastrol, a Small Molecule Inhibitor of the Mitotic Kinesin, Eg5 - PMC \[pmc.ncbi.nlm.nih.gov\]](#)
- [13. Calcium Channel Blockers - StatPearls - NCBI Bookshelf \[ncbi.nlm.nih.gov\]](#)
- [14. Inhibitors of the Hedgehog Signaling Pathway | Hadden Research Lab \[hadden.lab.uconn.edu\]](#)
- [15. Hedgehog pathway inhibitor - Wikipedia \[en.wikipedia.org\]](https://en.wikipedia.org)
- [16. Monastrol inhibition of the mitotic kinesin Eg5 - PubMed \[pubmed.ncbi.nlm.nih.gov\]](#)

- [17. Agonist Activation of a Nicotinic Acetylcholine Receptor - PMC \[pmc.ncbi.nlm.nih.gov\]](#)
- [18. Hedgehog pathway inhibitors – current status and future prospects - PMC \[pmc.ncbi.nlm.nih.gov\]](#)
- [19. Discovery and Development of Calcium Channel Blockers - PMC \[pmc.ncbi.nlm.nih.gov\]](#)
- [20. Nicotinic agonist - Wikipedia \[en.wikipedia.org\]](#)
- [21. Overview - Nicotinic Acetylcholine Receptor Signaling in Neuroprotection - NCBI Bookshelf \[ncbi.nlm.nih.gov\]](#)
- [22. Nicotinic acetylcholine receptor - Wikipedia \[en.wikipedia.org\]](#)
- [To cite this document: BenchChem. \[Validating the Biological Activity of Synthesized Tetrahydropyrimidines: A Comparative Guide\]. BenchChem, \[2026\]. \[Online PDF\]. Available at: \[https://www.benchchem.com/product/b140947/docs#validating-the-biological-activity-of-synthesized-tetrahydropyrimidines-a-comparative-guide\]](#)

Disclaimer & Data Validity:

The information provided in this document is for Research Use Only (RUO) and is strictly not intended for diagnostic or therapeutic procedures. While BenchChem strives to provide accurate protocols, we make no warranties, express or implied, regarding the fitness of this product for every specific experimental setup.

Technical Support: The protocols provided are for reference purposes. Unsure if this reagent suits your experiment?

Need Industrial/Bulk Grade? [Request Custom Synthesis Quote](#)

BenchChem

Our mission is to be the trusted global source of essential and advanced chemicals, empowering scientists and researchers to drive progress in science and industry.

Contact

Address: 3281 E Guasti Rd
Ontario, CA 91761, United States
Phone: (601) 213-4426
Email: info@benchchem.com

Contact our Ph.D. Support Team for a compatibility check