

# Measuring Adenosine Concentration In Vivo Using Microdialysis: Application Notes and Protocols

**Author:** BenchChem Technical Support Team. **Date:** May 2026

## Compound of Interest

Compound Name:	Adenosine
CAS No.:	133248-01-8
Cat. No.:	B140876

[Get Quote](#)

## Introduction: The Significance of In Vivo Adenosine Monitoring

**Adenosine** is a ubiquitous purine nucleoside that plays a critical role as a neuromodulator and homeostatic regulator in a vast array of physiological and pathophysiological processes.[1] It is a key signaling molecule in the cardiovascular system, influencing coronary blood flow and mitigating ischemia-reperfusion injury.[1][2][3] In the central nervous system, **adenosine** is implicated in the regulation of sleep-wake cycles, synaptic transmission, and neuroprotection.[4][5] Given its profound and widespread effects, the ability to accurately measure real-time changes in extracellular **adenosine** concentrations in vivo is of paramount importance for researchers in neuroscience, pharmacology, and drug development.

Microdialysis is a powerful and minimally invasive sampling technique that allows for the continuous monitoring of endogenous substances in the extracellular fluid of living tissues.[6][7] [8] When coupled with sensitive analytical methods, microdialysis provides an unparalleled window into the dynamic neurochemical and metabolic environment of specific tissue regions.

This guide provides a comprehensive overview of the principles, protocols, and practical considerations for measuring **adenosine** concentration in vivo using microdialysis, tailored for researchers, scientists, and drug development professionals.

## Adenosine Signaling Pathways: A Brief Overview

Extracellular **adenosine** exerts its effects by binding to four subtypes of G protein-coupled receptors: A1, A2A, A2B, and A3.[9][10] These receptors are widely distributed throughout the body and are coupled to different intracellular signaling cascades.[9][11] The A1 and A3 receptors typically couple to inhibitory G proteins (Gi/o), leading to a decrease in cyclic AMP (cAMP) levels.[9][10] Conversely, the A2A and A2B receptors are generally coupled to stimulatory G proteins (Gs), resulting in an increase in cAMP production.[9][11] This differential receptor coupling allows **adenosine** to elicit a wide range of cellular responses, from neuro-inhibition to vasodilation.

Diagram: **Adenosine** Receptor Signaling Pathways

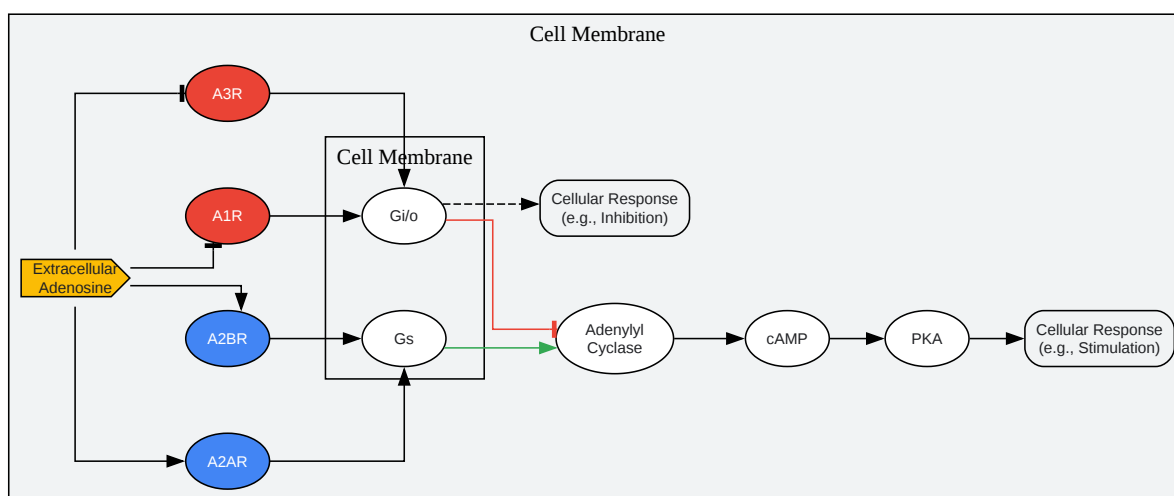

[Click to download full resolution via product page](#)

Caption: Simplified overview of **adenosine** receptor signaling pathways.

## Principles of In Vivo Microdialysis for Adenosine Measurement

Microdialysis operates on the principle of passive diffusion across a semi-permeable membrane.[7][12] A small, specialized probe is implanted into the target tissue, and a physiological solution, termed the perfusate, is slowly and continuously pumped through the probe.[6] Analytes present in the extracellular fluid, such as **adenosine**, diffuse across the membrane into the perfusate, creating a sample known as the dialysate. The dialysate is then collected at regular intervals and analyzed to determine the concentration of the analyte of interest.

Diagram: In Vivo Microdialysis Workflow

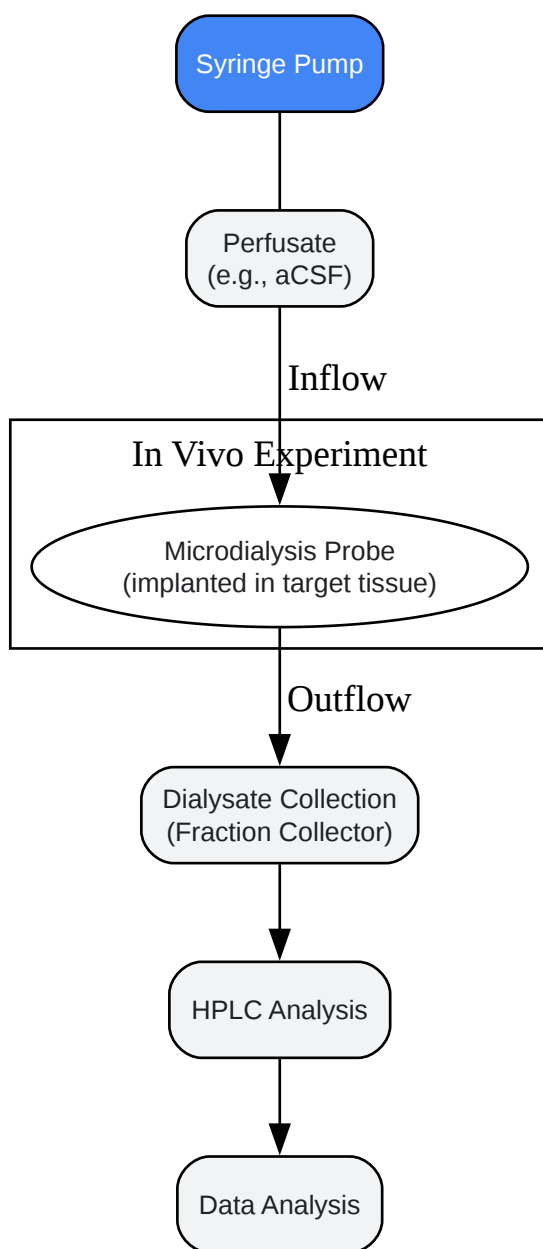

[Click to download full resolution via product page](#)

### Need Custom Synthesis?

BenchChem offers custom synthesis for rare earth carbides and specific isotopic labeling.

Email: [info@benchchem.com](mailto:info@benchchem.com) or [Request Quote Online](#).

## Sources

- [1. Adenosine: physiology, pharmacology, and clinical applications - PubMed \[pubmed.ncbi.nlm.nih.gov\]](#)
- [2. researchgate.net \[researchgate.net\]](#)
- [3. mdpi.com \[mdpi.com\]](#)
- [4. Microdialysis Elevation of Adenosine in the Basal Forebrain Produces Vigilance Impairments in the Rat Psychomotor Vigilance Task - PMC \[pmc.ncbi.nlm.nih.gov\]](#)
- [5. researchgate.net \[researchgate.net\]](#)
- [6. Microdialysis - In Vivo System for Neurotransmitter Recovery \[amuzainc.com\]](#)
- [7. Overview of Microdialysis - PMC \[pmc.ncbi.nlm.nih.gov\]](#)
- [8. criver.com \[criver.com\]](#)
- [9. researchgate.net \[researchgate.net\]](#)
- [10. journals.physiology.org \[journals.physiology.org\]](#)
- [11. Signaling pathways involving adenosine A2A and A2B receptors in wound healing and fibrosis - PMC \[pmc.ncbi.nlm.nih.gov\]](#)
- [12. Intracerebral microdialysis of adenosine and adenosine monophosphate – a systematic review and meta-regression analysis of baseline concentrations - PMC \[pmc.ncbi.nlm.nih.gov\]](#)
- [To cite this document: BenchChem. \[Measuring Adenosine Concentration In Vivo Using Microdialysis: Application Notes and Protocols\]. BenchChem, \[2026\]. \[Online PDF\]. Available at: \[https://www.benchchem.com/product/b140876/docs#measuring-adenosine-concentration-in-vivo-using-microdialysis-application-notes-and-protocols\]](#)

---

### Disclaimer & Data Validity:

The information provided in this document is for Research Use Only (RUO) and is strictly not intended for diagnostic or therapeutic procedures. While BenchChem strives to provide accurate protocols, we make no warranties, express or implied, regarding the fitness of this product for every specific experimental setup.

**Technical Support:** The protocols provided are for reference purposes. Unsure if this reagent suits your experiment?

**Need Industrial/Bulk Grade?** [Request Custom Synthesis Quote](#)

# BenchChem

Our mission is to be the trusted global source of essential and advanced chemicals, empowering scientists and researchers to drive progress in science and industry.

## Contact

Address: 3281 E Guasti Rd

Ontario, CA 91761, United States

Phone: (601) 213-4426

Email: [info@benchchem.com](mailto:info@benchchem.com)

[Contact our Ph.D. Support Team for a compatibility check](#)