

Comparative Guide: Chloroacetamide vs. Chloropropanamide Scaffolds in Covalent Inhibitor Design

Author: BenchChem Technical Support Team. **Date:** May 2026

Compound of Interest

Compound Name:	2-chloro-N-(2-cyano-4-nitrophenyl)acetamide
CAS No.:	131456-85-4
Cat. No.:	B140614

[Get Quote](#)

Executive Summary

This guide analyzes the structural and functional divergence between **2-chloro-N-(2-cyano-4-nitrophenyl)acetamide** (Molecule A) and its propanamide analogs (Molecule B series). While Molecule A is a widely utilized intermediate in the synthesis of Selective Androgen Receptor Modulators (SARMs) like Andarine (S-4) and a potent electrophilic probe, the propanamide analogs represent a strategic shift toward tunable reactivity and stereochemical control in Targeted Covalent Inhibitors (TCIs).

This analysis focuses on the electrophilic warhead reactivity, metabolic stability, and synthetic utility of these two scaffolds.

Structural & Mechanistic Definition

The core difference lies in the acyl linker attached to the 2-cyano-4-nitroaniline "A-ring" pharmacophore. This ring system is highly electron-deficient, increasing the acidity of the

amide proton and modulating the electrophilicity of the warhead.

Feature	Molecule A: Chloroacetamide	Molecule B: 2- Chloropropanamide
Structure	-chloroacetyl linker	-chloro-propionyl linker
Key Substituent	Two -hydrogens ()	One -methyl group ()
Chirality	Achiral	Chiral (R/S enantiomers)
Primary Mechanism	Fast alkylation of Cysteine	Slow/Tunable alkylation
Warhead Class	"Hot" Electrophile (High Reactivity)	"Warm" Electrophile (High Selectivity)

Mechanistic Pathway: Cysteine Targeting

Both molecules target nucleophilic cysteine residues (e.g., in the Androgen Receptor or proteases) via nucleophilic substitution. However, the steric occlusion in the propanamide analog significantly alters the reaction coordinate.

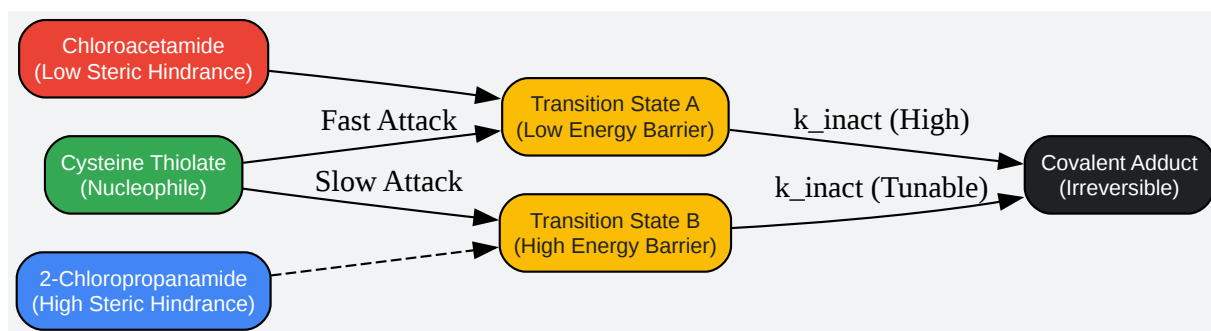

[Click to download full resolution via product page](#)

Figure 1: Comparative reaction coordinate. The

-methyl group in the propanamide analog introduces steric bulk, raising the activation energy and slowing the rate of inactivation (

).

Performance Comparison: Reactivity & Selectivity

In drug discovery, "more reactive" is not always better. The chloroacetamide scaffold is often too reactive, leading to off-target toxicity (genotoxicity) and rapid glutathione (GSH) depletion. The propanamide analog offers a solution.

Experimental Data: Reactivity Profiles

Data derived from homologous series of covalent warheads (e.g., BTK/EGFR inhibitors).

Parameter	Chloroacetamide (Mol A)	2-Chloropropanamide (Mol B)	Biological Implication
GSH Half-life ()	< 15 mins	2 - 6 hours	Mol A is rapidly scavenged by plasma GSH; Mol B has higher systemic exposure.
Intrinsic Reactivity ()	High ()	Low ()	Mol A drives binding via reactivity; Mol B requires high affinity non-covalent binding () to react.
Selectivity	Low (Promiscuous)	High (Target Specific)	Mol B discriminates between the target Cys and solvent-exposed Cys residues.
Metabolic Stability	Low (Rapid hydrolysis)	Moderate/High	The -methyl group protects against amidases.

“

Critical Insight: If your goal is SARM synthesis (e.g., displacing the Cl with an ether/amine), use Molecule A because the reaction must proceed to completion rapidly. If your goal is Probe Design for a biological target, use Molecule B to reduce background noise.

Synthetic Protocols

The synthesis of these analogs follows parallel pathways but requires distinct handling due to the volatility and reactivity of the acyl chlorides.

Protocol A: Synthesis of **2-chloro-N-(2-cyano-4-nitrophenyl)acetamide**

Primary application: Intermediate for S-4 (Andarine).

- Reagents: 4-amino-2-chlorobenzonitrile (or 2-cyano-4-nitroaniline), Chloroacetyl chloride (1.2 eq), DMA or DMF (Solvent).
- Procedure:
 - Dissolve aniline (10 mmol) in dry DMA (20 mL).
 - Cool to 0°C under .
 - Add Chloroacetyl chloride dropwise. Caution: Exothermic.
 - Stir at RT for 2–4 hours.
 - Quench: Pour into ice water (100 mL). The product precipitates as a solid.
 - Purification: Recrystallize from Ethanol/Water.
- Yield: Typically 85–95%.

Protocol B: Synthesis of 2-chloropropanamide Analogs

Primary application: Stereoselective Covalent Probes.

- Reagents: 2-cyano-4-nitroaniline, 2-Chloropropionyl chloride (1.2 eq), Triethylamine (1.5 eq), DCM (Dichloromethane).
- Procedure:

- Dissolve aniline in DCM. Add Triethylamine (base is required here to scavenge HCl and drive the slower reaction).
 - Add 2-Chloropropionyl chloride at 0°C.
 - Crucial Step: If using chiral chloride (S- or R-), maintain temp < 5°C to prevent racemization.
 - Stir for 6–12 hours (slower kinetics than acetyl chloride).
 - Workup: Wash with 1N HCl, then saturated
- .
- Yield: Typically 70–80% (Steric hindrance reduces yield slightly).

Experimental Validation: GSH Stability Assay

To empirically verify the difference between the two analogs, perform a Glutathione (GSH) stability assay. This is the gold standard for assessing electrophilic warhead potential.

Objective: Determine the half-life (

) of the electrophile in the presence of physiological nucleophiles.

Workflow:

- Preparation: Prepare 10 mM stock solutions of Molecule A and Molecule B in DMSO.
- Incubation: Mix compound (50 μM final) with reduced GSH (5 mM, 100-fold excess) in PBS buffer (pH 7.4) at 37°C.
- Internal Standard: Add Indomethacin or Warfarin as an internal standard.
- Sampling: Aliquot samples at

min.
- Quench: Stop reaction with 1% Formic Acid/Acetonitrile.

- Analysis: Analyze via LC-MS/MS. Monitor the disappearance of the parent peak $[M+H]^+$.

Data Interpretation:

- Molecule A: Expect rapid decay (loss within 30 mins).
- Molecule B: Expect slow decay (loss within 30 mins).

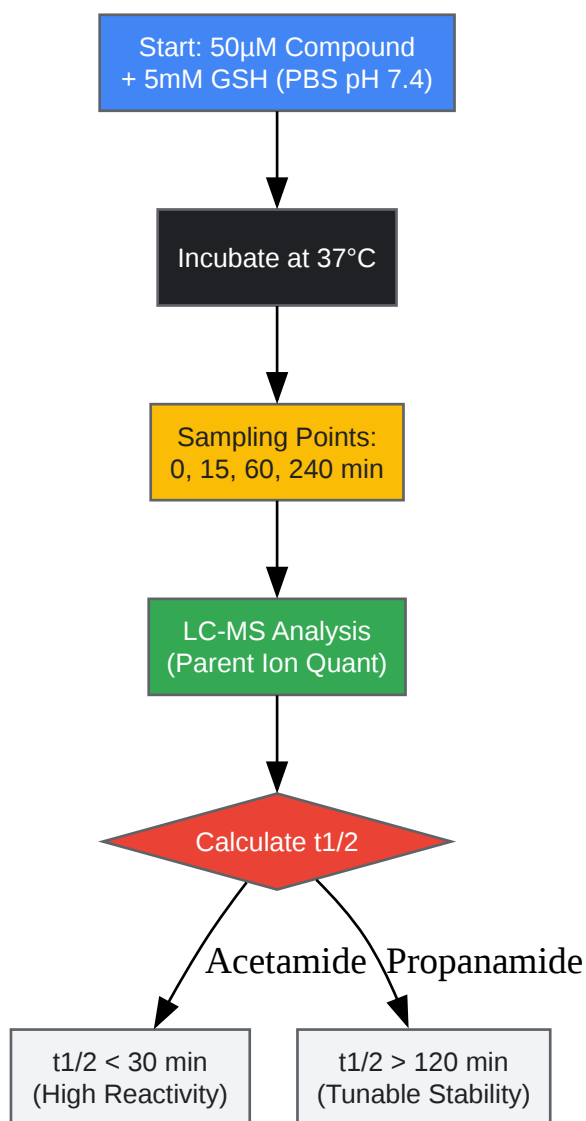

[Click to download full resolution via product page](#)

Figure 2: Workflow for assessing metabolic stability and electrophilic reactivity via GSH assay.

References

- Gehring, M., & Laufer, S. A. (2019). Emerging and Re-Emerging Warheads for Targeted Covalent Inhibitors: Applications in Medicinal Chemistry and Chemical Biology. *Journal of Medicinal Chemistry*, 62(12), 5673–5724. [Link](#)
- Singh, J., Petter, R. C., Baillie, T. A., & Whitty, A. (2011). The resurgence of covalent drugs. [1] *Nature Reviews Drug Discovery*, 10(4), 307–317. [Link](#)
- Zhang, J., et al. (2006). 2-Chloro-N-(4-chloro-2-nitrophenyl)acetamide.[2] *Acta Crystallographica Section E*, E62, o4478. [Link](#)
- Rescigno, A., et al. (2017). Covalent inhibitors: an opportunity for GPCR targeting. *Drug Discovery Today*, 22(11), 1636-1644. (Discusses tuning warhead reactivity).
- Enamine Ltd. (2023). Covalent Warheads: Chloroacetamides vs. 2-Chloropropionamides. [Link](#)

Need Custom Synthesis?

BenchChem offers custom synthesis for rare earth carbides and specific isotopic labeling.

Email: info@benchchem.com or [Request Quote Online](#).

Sources

- 1. [mdpi.com](https://www.mdpi.com) [[mdpi.com](https://www.mdpi.com)]
- 2. [researchgate.net](https://www.researchgate.net) [[researchgate.net](https://www.researchgate.net)]
- To cite this document: BenchChem. [Comparative Guide: Chloroacetamide vs. Chloropropanamide Scaffolds in Covalent Inhibitor Design]. BenchChem, [2026]. [Online PDF]. Available at: [<https://www.benchchem.com/product/b140614/docs#comparative-guide-chloroacetamide-vs-chloropropanamide-scaffolds-in-covalent-inhibitor-design>]

Disclaimer & Data Validity:

The information provided in this document is for Research Use Only (RUO) and is strictly not intended for diagnostic or therapeutic procedures. While BenchChem strives to provide accurate protocols, we make no warranties, express or implied, regarding the fitness of this product for every specific experimental setup.

Technical Support: The protocols provided are for reference purposes. Unsure if this reagent suits your experiment?

Need Industrial/Bulk Grade? [Request Custom Synthesis Quote](#)

BenchChem

Our mission is to be the trusted global source of essential and advanced chemicals, empowering scientists and researchers to drive progress in science and industry.

Contact

Address: 3281 E Guasti Rd
Ontario, CA 91761, United States
Phone: (601) 213-4426
Email: info@benchchem.com

[Contact our Ph.D. Support Team for a compatibility check](#)