

Application Notes & Protocols: A Guide to Sol-Gel Synthesis with Diamino-Functional Silanes

Author: BenchChem Technical Support Team. **Date:** April 2026

Compound of Interest

Compound Name: 3-(2-Aminoethylamino)propyldimethoxymethyl silane

Cat. No.: B13999592

[Get Quote](#)

For Researchers, Scientists, and Drug Development Professionals

Introduction: The Power of Diamino-Functionalization in Sol-Gel Science

The sol-gel process, a versatile wet-chemical technique, provides a powerful platform for synthesizing inorganic and hybrid organic-inorganic materials with tailored properties.^{[1][2]} At its core, the process involves the hydrolysis and condensation of molecular precursors, typically metal alkoxides, to form a colloidal suspension (sol) that subsequently evolves into a continuous solid network (gel).^{[1][3]} The ability to incorporate organic functionalities into this inorganic matrix opens up a vast design space for materials with specific chemical and physical characteristics.

Among the various functional groups, diamino-silanes, such as N-(2-aminoethyl)-3-aminopropyltrimethoxysilane (AEAPTMS), are of particular interest, especially in the realms of drug delivery, catalysis, and biomaterials.^{[4][5][6]} The presence of two amine groups offers enhanced reactivity and a higher density of functional sites compared to their monoamino

counterparts.[5] These amine groups act as internal base catalysts for the sol-gel reaction, accelerating the hydrolysis and condensation of the silica precursors.[7][8] This self-catalysis not only simplifies the synthesis but also influences the final structure and porosity of the material.[9] Furthermore, the amine groups provide reactive handles for the covalent attachment of therapeutic agents, targeting moieties, or other functional molecules, making these materials highly adaptable for advanced applications.[10][11]

This guide provides an in-depth exploration of the sol-gel synthesis procedures involving diamino-functional silanes. It is designed to equip researchers with the foundational knowledge and practical protocols necessary to design and fabricate amino-functionalized silica materials for a range of applications, with a particular focus on their relevance to drug development.

The Underlying Chemistry: Hydrolysis and Condensation

The sol-gel process is fundamentally a polymerization reaction. It begins with the hydrolysis of the silicon alkoxide precursors, where the alkoxy groups (-OR) are replaced with hydroxyl groups (-OH). This is followed by a condensation reaction, where siloxane bridges (Si-O-Si) are formed, leading to the growth of the silica network.[12][13]

Hydrolysis: $\text{Si}(\text{OR})_4 + \text{H}_2\text{O} \rightleftharpoons (\text{HO})\text{Si}(\text{OR})_3 + \text{ROH}$

Condensation (Water-producing): $(\text{OR})_3\text{Si-OH} + \text{HO-Si}(\text{OR})_3 \rightleftharpoons (\text{OR})_3\text{Si-O-Si}(\text{OR})_3 + \text{H}_2\text{O}$

Condensation (Alcohol-producing): $(\text{OR})_3\text{Si-OR} + \text{HO-Si}(\text{OR})_3 \rightleftharpoons (\text{OR})_3\text{Si-O-Si}(\text{OR})_3 + \text{ROH}$

The rates of these reactions are highly dependent on factors such as pH, water-to-alkoxide ratio, solvent, and temperature.[1] Diamino-functional silanes introduce a unique variable: the amine groups themselves act as base catalysts, accelerating the hydrolysis and condensation steps.[7] This is due to the lone pair of electrons on the nitrogen atom, which can deprotonate water, making it a more effective nucleophile for attacking the silicon center.

Diagram: The Catalytic Role of Diamino-Silanes in Sol-Gel Formation

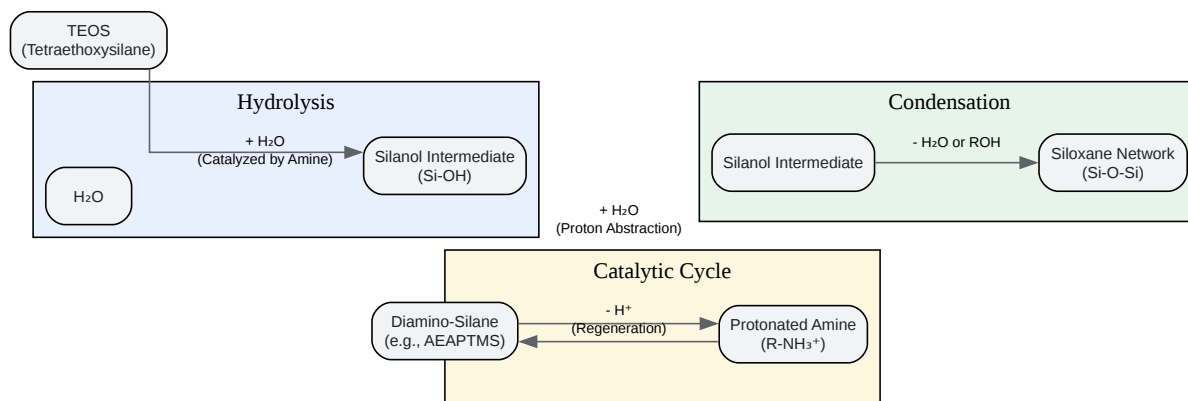

[Click to download full resolution via product page](#)

Caption: Catalytic cycle of diamino-silanes in the sol-gel process.

Synthetic Strategies: Co-condensation vs. Post-synthesis Grafting

There are two primary methods for incorporating diamino-functional silanes into a silica matrix: co-condensation and post-synthesis grafting. The choice between these methods significantly impacts the distribution of the amino groups and the final material properties.^{[10][14]}

- **Co-condensation:** In this one-pot synthesis, the diamino-functional silane is mixed with the primary silica precursor (e.g., tetraethoxysilane, TEOS) from the beginning of the reaction. ^{[10][14]} This approach generally leads to a more homogeneous distribution of amino groups throughout the silica framework.^{[10][14]} However, the presence of the aminosilane can influence the particle size and morphology.^[15]
- **Post-synthesis Grafting:** This two-step method involves first synthesizing the silica particles or monolith and then reacting the surface silanol groups with the diamino-functional silane. ^{[14][16]} This method allows for better control over the silica particle's initial size and shape.

However, the functionalization is limited to the surface, and achieving a high density of amino groups can be challenging.

Parameter	Co-condensation	Post-synthesis Grafting
Amino Group Distribution	Homogeneous throughout the matrix[10][14]	Primarily on the surface[14][16]
Process Complexity	Simpler, one-pot synthesis[14]	More complex, multi-step process[16]
Control over Particle Size	Can be influenced by the aminosilane[15]	Better control over initial particle size
Potential for Pore Blockage	Less likely	Can lead to pore blockage if not optimized
Typical Application	Materials requiring bulk functionalization	Surface-specific modifications

Experimental Protocols

The following protocols provide a starting point for the synthesis of diamino-functionalized silica nanoparticles. It is crucial to note that these are generalized procedures, and optimization of parameters such as precursor concentrations, reaction time, and temperature may be necessary for specific applications.

This protocol is adapted from the Stöber method for synthesizing monodisperse silica nanoparticles.[15][16]

Materials:

- Tetraethoxysilane (TEOS)
- N-(2-aminoethyl)-3-aminopropyltrimethoxysilane (AEAPTMS)[4][6]
- Ethanol (absolute)
- Ammonium hydroxide solution (28-30%)

- Deionized water

Procedure:

- In a flask, combine ethanol, deionized water, and ammonium hydroxide solution. Stir the mixture vigorously at room temperature.
- In a separate container, prepare a mixture of TEOS and AEAPTMS at the desired molar ratio.
- Add the TEOS/AEAPTMS mixture dropwise to the stirred ethanol/water/ammonia solution.
- Allow the reaction to proceed for a specified time (e.g., 2-24 hours) with continuous stirring. The solution will become turbid as the silica nanoparticles form.
- Collect the nanoparticles by centrifugation.
- Wash the nanoparticles several times with ethanol and then with deionized water to remove any unreacted precursors and ammonia.
- Dry the nanoparticles in an oven or by lyophilization.

Key Considerations:

- The ratio of water to TEOS and the concentration of ammonia will significantly influence the size of the resulting nanoparticles.[\[17\]](#)
- The molar ratio of AEAPTMS to TEOS will determine the density of amino groups in the final material.[\[15\]](#)

This protocol assumes you have pre-synthesized silica nanoparticles.

Materials:

- Pre-synthesized silica nanoparticles
- N-(2-aminoethyl)-3-aminopropyltrimethoxysilane (AEAPTMS)

- Toluene (anhydrous)

Procedure:

- Disperse the pre-synthesized silica nanoparticles in anhydrous toluene via sonication.
- Add AEAPTMS to the nanoparticle suspension.
- Reflux the mixture under an inert atmosphere (e.g., nitrogen or argon) for a specified time (e.g., 12-24 hours) with stirring.
- Allow the mixture to cool to room temperature.
- Collect the functionalized nanoparticles by centrifugation.
- Wash the nanoparticles extensively with toluene and then with ethanol to remove any unreacted AEAPTMS.
- Dry the functionalized nanoparticles under vacuum.

Key Considerations:

- The surface of the silica nanoparticles should have a high density of silanol groups for efficient grafting. This can sometimes be achieved by an acid or base treatment prior to the grafting step.
- The reaction must be carried out under anhydrous conditions to prevent self-condensation of the AEAPTMS in solution.^[7]

Diagram: Experimental Workflow for Synthesis Methods

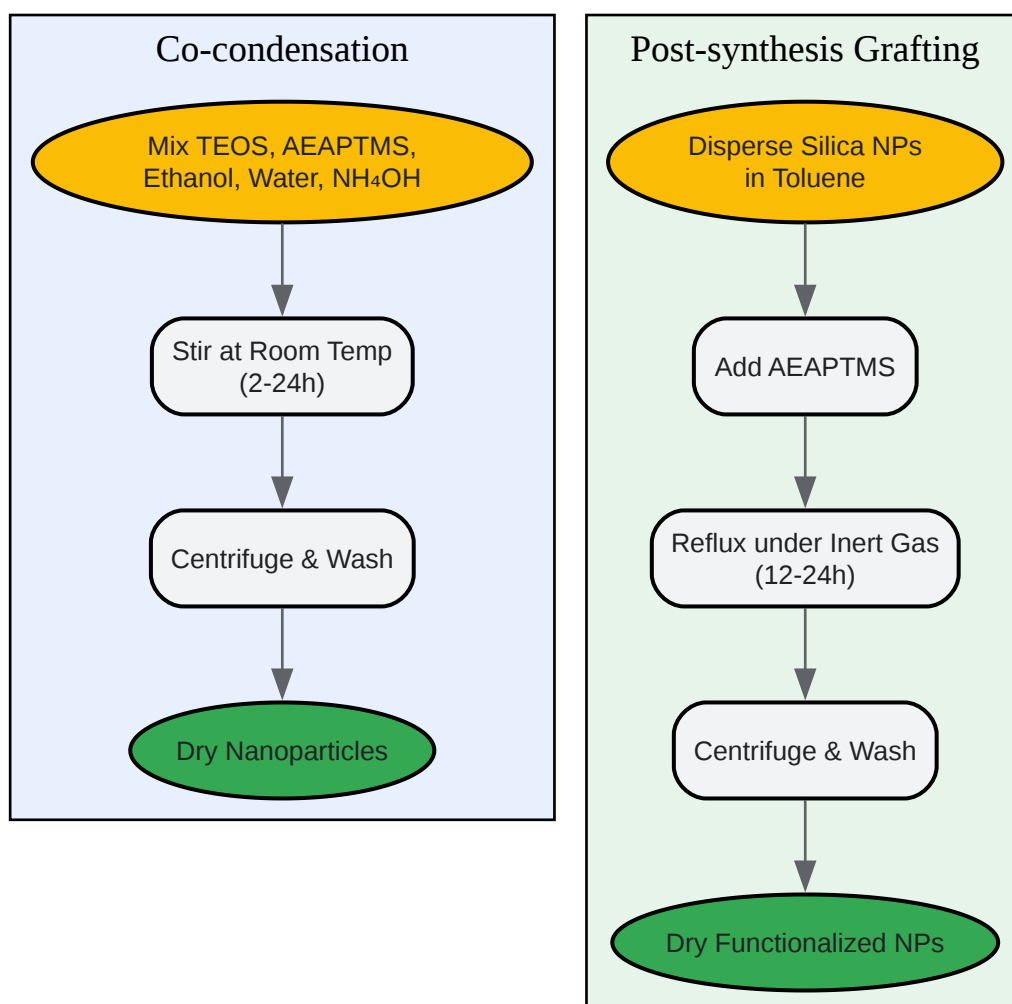

[Click to download full resolution via product page](#)

Caption: Workflow for co-condensation and post-synthesis grafting.

Characterization of Diamino-Functionalized Silica

A thorough characterization of the synthesized materials is essential to confirm successful functionalization and to understand their properties.

Technique	Information Obtained
Fourier-Transform Infrared Spectroscopy (FTIR)	Confirmation of the presence of amino groups (N-H stretching and bending vibrations) and siloxane bonds (Si-O-Si).[9]
Solid-State ²⁹ Si Nuclear Magnetic Resonance (NMR)	Provides information about the degree of condensation of the silica network (Q species) and the incorporation of the aminosilane (T species).[8]
Thermogravimetric Analysis (TGA)	Quantifies the amount of organic functional groups by measuring the weight loss upon heating.
Elemental Analysis (CHN)	Determines the nitrogen content, which can be used to calculate the concentration of amino groups.[18]
Zeta Potential Measurement	Indicates the surface charge of the particles. Amino-functionalized particles will have a positive zeta potential at neutral or acidic pH. [17]
Transmission Electron Microscopy (TEM) / Scanning Electron Microscopy (SEM)	Visualizes the morphology, size, and dispersity of the nanoparticles.[16]
Nitrogen Adsorption-Desorption (BET Analysis)	Determines the specific surface area, pore volume, and pore size distribution.[9]

Applications in Drug Development

The unique properties of diamino-functionalized silica materials make them highly attractive for various applications in drug development.

- **Drug Delivery:** The amino groups can be used to electrostatically or covalently bind drug molecules.[11][19] The positive surface charge can also enhance interaction with negatively charged cell membranes. The pH-responsive nature of the amino groups can be exploited for controlled drug release in specific microenvironments, such as tumors.[19]

- **Gene Delivery:** The positively charged surface can effectively complex with negatively charged nucleic acids (DNA, siRNA), protecting them from degradation and facilitating their cellular uptake.
- **Biocatalysis:** Enzymes can be immobilized onto the amino-functionalized silica surface, providing a stable and reusable biocatalyst system.[9]
- **Scavengers:** These materials can be used to scavenge residual heavy metal catalysts from pharmaceutical synthesis processes.[20]

Conclusion

Sol-gel synthesis involving diamino-functional silanes offers a robust and versatile platform for creating advanced materials with a wide range of applications, particularly in the pharmaceutical and biomedical fields. By understanding the underlying chemistry and carefully selecting the synthetic strategy, researchers can tailor the properties of these materials to meet the specific demands of their application. The protocols and characterization techniques outlined in this guide provide a solid foundation for the successful design and fabrication of these promising materials.

References

- Mesoporous Silica Nanoparticles Functionalized with Amino Groups for Biomedical Applications - PMC. (URL: [\[Link\]](#))
- Synthesis and characterization of amino-functionalized silica nanoparticles - ResearchGate. (URL: [\[Link\]](#))
- Mesoporous Silica Nanoparticles Functionalized with Amino Groups for Biomedical Applications. (URL: [\[Link\]](#))
- Amino-functionalized low density silica xerogels seen by different characterization methods. (URL: [\[Link\]](#))
- Synthesis and Rapid Characterization of Amine-Functionalized Silica - ACS Publications. (URL: [\[Link\]](#))

- One-pot synthesis and application of novel amino-functionalized silica nanoparticles using guanidine as amino group - New Journal of Chemistry (RSC Publishing). (URL: [\[Link\]](#))
- Covalently functionalized uniform amino-silica nanoparticles. Synthesis and validation of amine group accessibility and stability - Nanoscale Advances (RSC Publishing). (URL: [\[Link\]](#))
- Facile Fabrication and Characterization of Amine-Functional Silica Coated Magnetic Iron Oxide Nanoparticles for Aqueous Carbon Dioxide Adsorption | ACS Omega - ACS Publications. (URL: [\[Link\]](#))
- Controllable Synthesis of Amino-Functionalized Silica Particles via Co-condensation of Tetraethoxysilane and (3-Aminopropyl)triethoxysilane | Langmuir - ACS Publications. (URL: [\[Link\]](#))
- Fig.S2 Probable hydrolysis and condensation reactions of aminosilane... - ResearchGate. (URL: [\[Link\]](#))
- Controlled Interphases in Glass Fiber and Particulate Reinforced Polymers: Structure of Silane Coupling Agents in Solutions and - DTIC. (URL: [\[Link\]](#))
- Polymer-amino-functionalized silica composites for multiparticulate systems. (URL: [\[Link\]](#))
- Hydrolysis and condensation reactions associated with an amino alkyl... - ResearchGate. (URL: [\[Link\]](#))
- Sol-Gel Synthesis and Physicochemical Properties of Organosilicon Materials Functionalized by Amino Groups | Request PDF - ResearchGate. (URL: [\[Link\]](#))
- N-(2-AMINOETHYL)-3-AMINOPROPYLTRIMETHOXYSILANE, tech - Gelest, Inc. (URL: [\[Link\]](#))
- Silane Coupling Agents - Shin-Etsu. (URL: [\[Link\]](#))
- Amino functionalized chiral mesoporous silica nanoparticles for improved loading and release of poorly water-soluble drug - NIH. (URL: [\[Link\]](#))

- Factors contributing to the stability of alkoxy silanes in aqueous solution - Gelest, Inc. (URL: [\[Link\]](#))
- Schematic illustration of drug loading of silica and amine-modified samples - ResearchGate. (URL: [\[Link\]](#))
- Amine Functionalization of Silica Sol–Gel Thin Films via Kinetic Doping: A Novel, Green Approach - PMC - NIH. (URL: [\[Link\]](#))
- Amino-functionalized Mesoporous Silica Nanoparticles as Efficient Carriers for Anticancer Drug Delivery - PubMed. (URL: [\[Link\]](#))
- The Design of Anionic Surfactant-Based Amino-Functionalized Mesoporous Silica Nanoparticles and their Application in Transdermal Drug Delivery - PMC. (URL: [\[Link\]](#))
- Amino Silica Gel | Sorbent Technologies, Inc. (URL: [\[Link\]](#))
- Amine Functionalization of Silica Sol–Gel Thin Films via Kinetic Doping: A Novel, Green Approach | ACS Omega - ACS Publications. (URL: [\[Link\]](#))
- Recent advances in mesoporous silica nanoparticle: synthesis, drug loading, release mechanisms, and diverse applications - Frontiers. (URL: [\[Link\]](#))
- Supplier of N-2-(AMINOETHYL)-3-AMINOPROPYLTRIMETHOXYSILANE | Bulk Manufacturer & Distributor - Silsource. (URL: [\[Link\]](#))
- Impact of Mesoporous Silica Functionalization Fine-Tuning on Antibiotic Uptake/Delivery and Bactericidal Activity | ACS Omega. (URL: [\[Link\]](#))
- N-(2-aminoethyl)- 3-aminopropyltrimethoxysilane CAS 1760-24-3 - Silico. (URL: [\[Link\]](#))
- Sol–gel process - Wikipedia. (URL: [\[Link\]](#))
- Amino-Alcohol Organic-Inorganic Hybrid Sol-Gel Materials Based on an Epoxy Bicyclic Silane: Synthesis and Characterization - MDPI. (URL: [\[Link\]](#))
- The evolution of 'sol–gel' chemistry as a technique for materials synthesis - RSC Publishing. (URL: [\[Link\]](#))

- 1. Organo-Functional Silanes. (URL: [\[Link\]](#))
- Biomimetic Sol–Gel Chemistry to Tailor Structure, Properties, and Functionality of Bionanocomposites by Biopolymers and Cells - MDPI. (URL: [\[Link\]](#))
- Advances in the Modification of Silane-Based Sol-Gel Coating to Improve the Corrosion Resistance of Magnesium Alloys - MDPI. (URL: [\[Link\]](#))
- (PDF) Advances in the Modification of Silane-Based Sol-Gel Coating to Improve the Corrosion Resistance of Magnesium Alloys - ResearchGate. (URL: [\[Link\]](#))
- Using Sugar and Amino Acid Additives to Stabilize Enzymes within Sol–Gel Derived Silica | Chemistry of Materials - ACS Publications. (URL: [\[Link\]](#))
- Sol-gel synthesis and microstructure analysis of amino-modified hybrid silica nanoparticles from aminopropyltriethoxysilane and tetraethoxysilane - Kyushu University Pure Portal Site. (URL: [\[Link\]](#))
- Sol-gel Coating Processes. (URL: [\[Link\]](#))
- One-pot synthesis of silane-modified hyaluronic acid hydrogels for effective antibacterial drug delivery via sol-gel stabilization - PubMed. (URL: [\[Link\]](#))
- (PDF) The Role of Silane Sol-Gel Coatings on the Corrosion Protection of Magnesium Alloys. (URL: [\[Link\]](#))
- Development of a Tailored Sol-Gel Immobilized Biocatalyst for Sustainable Synthesis of the Food Aroma Ester n-Amyl Caproate in Continuous Solventless System - PMC. (URL: [\[Link\]](#))

Need Custom Synthesis?

BenchChem offers custom synthesis for rare earth carbides and specific isotopic labeling.

Email: info@benchchem.com or [Request Quote Online](#).

Sources

- 1. Sol–gel process - Wikipedia [\[en.wikipedia.org\]](https://en.wikipedia.org)

- [2. The evolution of 'sol-gel' chemistry as a technique for materials synthesis - Materials Horizons \(RSC Publishing\) \[pubs.rsc.org\]](#)
- [3. uobabylon.edu.iq \[uobabylon.edu.iq\]](#)
- [4. N-\(2-AMINOETHYL\)-3-AMINOPROPYLTRIMETHOXYSILANE, tech - Gelest, Inc. \[gelest.com\]](#)
- [5. unitedchem.com \[unitedchem.com\]](#)
- [6. Supplier of N-2-\(AMINOETHYL\)-3-AMINOPROPYLTRIMETHOXYSILANE | Bulk Manufacturer & Distributor \[silsource.com\]](#)
- [7. apps.dtic.mil \[apps.dtic.mil\]](#)
- [8. kyushu-u.elsevierpure.com \[kyushu-u.elsevierpure.com\]](#)
- [9. Redirecting \[linkinghub.elsevier.com\]](#)
- [10. d-nb.info \[d-nb.info\]](#)
- [11. The Design of Anionic Surfactant-Based Amino-Functionalized Mesoporous Silica Nanoparticles and their Application in Transdermal Drug Delivery - PMC \[pmc.ncbi.nlm.nih.gov\]](#)
- [12. Frontiers | Recent advances in mesoporous silica nanoparticle: synthesis, drug loading, release mechanisms, and diverse applications \[frontiersin.org\]](#)
- [13. mdpi.com \[mdpi.com\]](#)
- [14. Mesoporous Silica Nanoparticles Functionalized with Amino Groups for Biomedical Applications - PMC \[pmc.ncbi.nlm.nih.gov\]](#)
- [15. pubs.acs.org \[pubs.acs.org\]](#)
- [16. researchgate.net \[researchgate.net\]](#)
- [17. pubs.acs.org \[pubs.acs.org\]](#)
- [18. One-pot synthesis and application of novel amino-functionalized silica nanoparticles using guanidine as amino group - New Journal of Chemistry \(RSC Publishing\) \[pubs.rsc.org\]](#)
- [19. Amino-functionalized mesoporous silica nanoparticles as efficient carriers for anticancer drug delivery - PubMed \[pubmed.ncbi.nlm.nih.gov\]](#)
- [20. sorbtech.com \[sorbtech.com\]](#)
- [To cite this document: BenchChem. \[Application Notes & Protocols: A Guide to Sol-Gel Synthesis with Diamino-Functional Silanes\]. BenchChem, \[2026\]. \[Online PDF\]. Available at: \[https://www.benchchem.com/product/b13999592/docs#application-notes-protocols-a-guide-to-sol-gel-synthesis-with-diamino-functional-silanes\]](#)

Disclaimer & Data Validity:

The information provided in this document is for Research Use Only (RUO) and is strictly not intended for diagnostic or therapeutic procedures. While BenchChem strives to provide accurate protocols, we make no warranties, express or implied, regarding the fitness of this product for every specific experimental setup.

Technical Support: The protocols provided are for reference purposes. Unsure if this reagent suits your experiment?

Need Industrial/Bulk Grade? [Request Custom Synthesis Quote](#)

BenchChem

Our mission is to be the trusted global source of essential and advanced chemicals, empowering scientists and researchers to drive progress in science and industry.

Contact

Address: 3281 E Guasti Rd
Ontario, CA 91761, United States
Phone: (601) 213-4426
Email: info@benchchem.com

[Contact our Ph.D. Support Team for a compatibility check](#)