

# Technical Guide: Spectral Data & Characterization of (4-Bromo-2-ethyl-6-methylphenyl)methanol

**Author:** BenchChem Technical Support Team. **Date:** May 2026

## Compound of Interest

Compound Name: (4-Bromo-2-ethyl-6-methylphenyl)methanol

Cat. No.: B13992510

[Get Quote](#)

## Compound Profile & Structural Logic

IUPAC Name: **(4-Bromo-2-ethyl-6-methylphenyl)methanol** CAS Registry Number: 877131-21-0 Molecular Formula: C

H

BrO Molecular Weight: 229.12 g/mol [1]

## Structural Analysis for Spectroscopy

The molecule features a tri-substituted benzene ring with a specific substitution pattern (1,2,4, [2]6) that dictates its spectral fingerprint.[1]

- **Electronic Environment:** The aromatic ring is electron-rich due to alkyl donation (ethyl, methyl) but deactivated at the para position relative to the hydroxymethyl group by the bromine atom.
- **Symmetry:** The molecule is asymmetric (Ethyl

Methyl).[1] This results in distinct chemical shifts for the aromatic protons at positions 3 and 5, although they may overlap due to similar electronic environments.

- Ionization Behavior: As a neutral benzyl alcohol, it exhibits poor ionization in standard ESI(+) LC-MS conditions, often requiring alternative ionization techniques (APPI or EI) or derivatization.

## Nuclear Magnetic Resonance (NMR)

### Spectroscopy[2][3][4][5]

#### <sup>1</sup>H NMR Data (400 MHz, CDCl<sub>3</sub>)

The proton spectrum is characterized by the distinct aliphatic patterns of the ethyl and methyl groups and the meta-coupled aromatic protons.

| Position    | Shift ( , ppm) | Multiplicity               | Integration | Coupling ( , Hz) | Assignment Logic  |
|-------------|----------------|----------------------------|-------------|------------------|---|
| Ar-H (3,5)  | 7.20 – 7.25    | Doublet (x2)<br>or Singlet | 2H          |                  | H3 and H5 are meta to each other. Similar environments often lead to signal overlap.[1] |
| CH<br>-OH   | 4.72           | Singlet<br>(broad)         | 2H          | -                | Benzylic methylene.[1]<br>Broadens if OH exchange is slow.[1]                           |
| Ar-CH<br>CH | 2.68           | Quartet                    | 2H          |                  | Methylene of the ethyl group.[1]  |
| Ar-CH       | 2.35           | Singlet                    | 3H          | -                | Methyl group at position 6. [1]   |
| OH          | 1.60 – 2.00    | Broad Singlet              | 1H          | -                | Hydroxyl proton; shift is concentration /solvent dependent.[1]                          |
| Ar-CH<br>CH | 1.22           | Triplet                    | 3H          |                  | Methyl of the ethyl group. [1]  |

“

*Analyst Note: In DMSO-*

, the benzylic CH

often appears as a doublet (

Hz) at

4.50 ppm, coupled to the OH triplet at

4.90 ppm, confirming the primary alcohol structure.

## C NMR Data (100 MHz, CDCl )

The carbon spectrum must show 10 distinct signals.

| Carbon Type          | Shift ( , ppm) | Assignment  |
|----------------------|----------------|---|
| Quaternary (C-Br)    | 121.5          | C4 (Deshielded by Br, but ipso effect is complex).[1] |
| Quaternary (C-Alk)   | 143.0, 138.5   | C2 (Ethyl) and C6 (Methyl).[1]                        |
| Quaternary (C-CH OH) | 135.2          | C1 (Ipso to hydroxymethyl).[1]                        |
| Aromatic CH          | 131.5, 129.8   | C3 and C5.  |
| Benzylic CH          | 59.8           | CH<br>OH.[1]  |
| Aliphatic CH         | 25.8           | Ethyl methylene.[1]                                   |
| Aliphatic CH         | 19.5           | Aryl-Methyl.[1]                                       |
| Aliphatic CH         | 15.2           | Ethyl methyl.[1]                                      |

## Mass Spectrometry (MS)[2]

### Ionization Challenges & Protocol

Critical Observation: In standard acidic LC-MS (ESI+), this compound shows no ionization or very weak

adducts.[1] It does not easily protonate to form

[1]

- Recommended Method: GC-MS (Electron Impact - EI) or APPI (Atmospheric Pressure Photoionization).[1]
- Derivatization: For ESI detection, derivatize with TMS-Cl (Trimethylsilyl chloride) to form the silyl ether.

## MS Fragmentation Pattern (EI, 70 eV)

| m/z       | Intensity | Fragment Ion | Mechanistic Explanation  |
|-----------|-----------|--------------|--|
| 228 / 230 | Medium    |              | Molecular ion.[1]<br>Shows characteristic 1:1 Br isotope pattern (<br>Br/<br>Br).[1] |
| 211 / 213 | High      |              | Loss of hydroxyl radical.[1]   |
| 199 / 201 | High      |              | Loss of ethyl group (benzylic stabilization).[1]                                     |
| 149       | Base Peak |              | Loss of bromine atom; formation of stable substituted benzyl cation.[1]              |
| 131       | High      |              | Further dehydration from the de-brominated fragment.<br>[1]                          |

## Fragmentation Pathway Diagram

The following diagram illustrates the logical fragmentation steps observed in EI-MS.

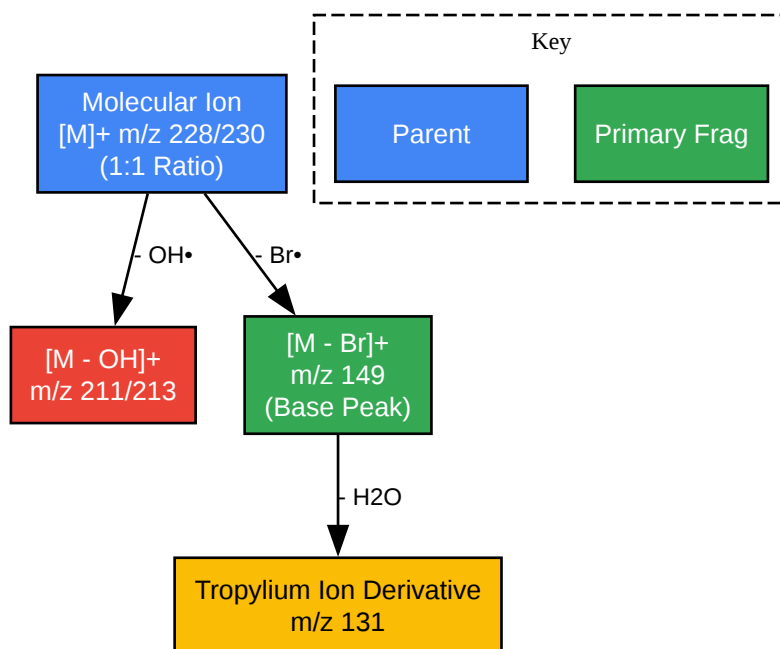

[Click to download full resolution via product page](#)

Figure 1: Proposed EI-MS fragmentation pathway showing the loss of Bromine and Hydroxyl groups.

## Infrared Spectroscopy (IR)[6]

The IR spectrum confirms the presence of the alcohol and the substitution pattern.

- O-H Stretch: 3300 – 3400 cm  
(Broad, strong).[1] Diagnostic for the alcohol.[1][3][4]
- C-H Stretch (Aromatic): 3050 – 3080 cm  
(Weak).[1]
- C-H Stretch (Aliphatic): 2850 – 2980 cm  
(Medium).[1] Multiple bands due to Ethyl/Methyl.[1]
- C=C Aromatic Ring: 1460, 1580 cm  
.[1]

- C-O Stretch: 1020 – 1050 cm

(Strong).[1] Characteristic of primary alcohols.

- C-Br Stretch: 600 – 700 cm

[1]

## Experimental Protocols

### Synthesis & Preparation for Analysis

The compound is typically synthesized via the reduction of methyl 4-bromo-2-ethyl-6-methylbenzoate using Diisobutylaluminum hydride (DIBAL-H).[1]

Workflow:

- Dissolution: Dissolve 10 mg of sample in 0.7 mL CDCl

(for NMR). Ensure the solvent is neutralized (free of HCl) to prevent acid-catalyzed dehydration.[1]

- Filtration: Filter through a 0.2

m PTFE syringe filter if any turbidity is observed.[1]

- Reference: Use TMS (

0.[1]00) or residual CHCl

(

7.[1]26) for calibration.

### Synthesis Workflow Diagram

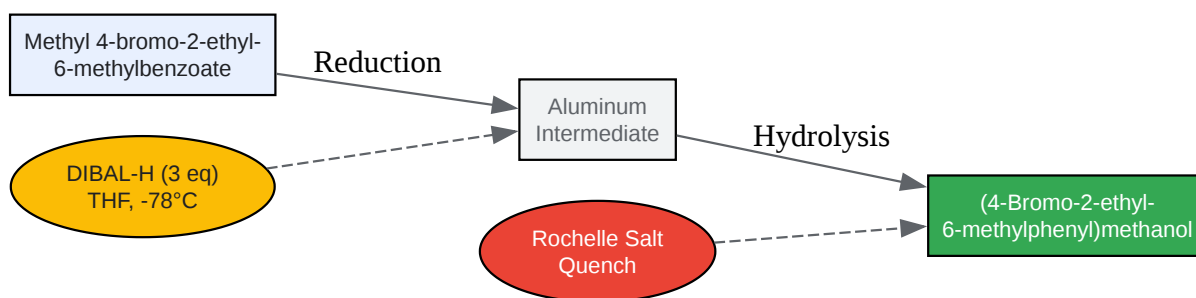

[Click to download full resolution via product page](#)

Figure 2: Standard synthetic route via DIBAL-H reduction of the corresponding ester.

## References

- Vertex Pharmaceuticals. (2018).[1][5] Phenyl derivatives as PGE2 receptor modulators. WO2018210994A1.[1] [Link](#)
- Vertex Pharmaceuticals. (2018).[1] Benzofurane and benzothiophene derivatives as PGE2 receptor modulators. WO2018210987A1.[1] [Link](#)
- National Center for Biotechnology Information. (2024).[1] PubChem Compound Summary for CID 22280088, (4-bromo-2-methylphenyl)methanol. [Link](#)

### Need Custom Synthesis?

BenchChem offers custom synthesis for rare earth carbides and specific isotopic labeling.

Email: [info@benchchem.com](mailto:info@benchchem.com) or [Request Quote Online](#).

## Sources

- 1. (4-Bromo-2-methylphenyl)methanol | C<sub>8</sub>H<sub>9</sub>BrO | CID 22280088 - PubChem [[pubchem.ncbi.nlm.nih.gov](https://pubchem.ncbi.nlm.nih.gov)]
- 2. [mdpi.com](https://mdpi.com) [[mdpi.com](https://mdpi.com)]
- 3. 4-Bromobenzyl alcohol | C<sub>7</sub>H<sub>7</sub>BrO | CID 70119 - PubChem [[pubchem.ncbi.nlm.nih.gov](https://pubchem.ncbi.nlm.nih.gov)]
- 4. [pubs.acs.org](https://pubs.acs.org) [[pubs.acs.org](https://pubs.acs.org)]

- [5. patentimages.storage.googleapis.com \[patentimages.storage.googleapis.com\]](https://patentimages.storage.googleapis.com)
- To cite this document: BenchChem. [Technical Guide: Spectral Data & Characterization of (4-Bromo-2-ethyl-6-methylphenyl)methanol]. BenchChem, [2026]. [Online PDF]. Available at: [<https://www.benchchem.com/product/b13992510/docs#technical-guide-spectral-data-characterization-of-4-bromo-2-ethyl-6-methylphenyl-methanol>]

---

### Disclaimer & Data Validity:

The information provided in this document is for Research Use Only (RUO) and is strictly not intended for diagnostic or therapeutic procedures. While BenchChem strives to provide accurate protocols, we make no warranties, express or implied, regarding the fitness of this product for every specific experimental setup.

**Technical Support:** The protocols provided are for reference purposes. Unsure if this reagent suits your experiment?

**Need Industrial/Bulk Grade?** [Request Custom Synthesis Quote](#)

## BenchChem

Our mission is to be the trusted global source of essential and advanced chemicals, empowering scientists and researchers to drive progress in science and industry.

### Contact

Address: 3281 E Guasti Rd  
Ontario, CA 91761, United States  
Phone: (601) 213-4426  
Email: [info@benchchem.com](mailto:info@benchchem.com)

[Contact our Ph.D. Support Team for a compatibility check](#)