

Optimized Synthesis Protocols for 2-Bromo-5-(2-chlorophenyl)pyrimidine

Author: BenchChem Technical Support Team. **Date:** April 2026

Compound of Interest

Compound Name: 2-Bromo-5-(2-chlorophenyl)pyrimidine

Cat. No.: B13981060

[Get Quote](#)

Application Note: Strategies for Regioselectivity and Scale-Up

Executive Summary

The synthesis of **2-Bromo-5-(2-chlorophenyl)pyrimidine** presents a classic chemoselectivity challenge in heterocyclic chemistry. The target molecule contains two halogenated sites: a chemically labile bromine at the 2-position (activated for nucleophilic aromatic substitution,

) and a sterically crowded 2-chlorophenyl group at the 5-position.

Direct Suzuki-Miyaura coupling of 2,5-dibromopyrimidine often leads to mixtures of regioisomers or over-coupled products (bis-arylation). Furthermore, the ortho-chloro substituent on the boronic acid introduces steric hindrance, requiring catalytically active palladium species.

This guide details two optimized protocols designed to bypass these pitfalls:

- The "Late-Stage Bromination" Route (Recommended for High Purity): Utilizes an amino group as a masked halide, coupling first and converting to bromine via a non-aqueous

Sandmeyer reaction.

- The "Halogen Exchange" Route (Recommended for Cost-Efficiency): Utilizes the cheaper 5-bromo-2-chloropyrimidine, coupling at C5, followed by a robust Cl

Br exchange.

Strategic Analysis & Retrosynthesis

The pyrimidine ring possesses distinct electronic environments at C2 and C5.^[1]

- C2 Position (Between Nitrogens): Highly electron-deficient. Prone to oxidative addition with electron-rich metal centers.
- C5 Position: Resembles a standard aryl halide.
- Reactivity Order (Pd-Catalyzed): Generally C5-Br > C2-Cl. However, C2-Br is highly reactive and unstable during basic coupling conditions (prone to hydrolysis to the pyrimidone).

Therefore, introducing the sensitive C2-Bromine after the carbon-carbon bond formation is the most reliable strategy.

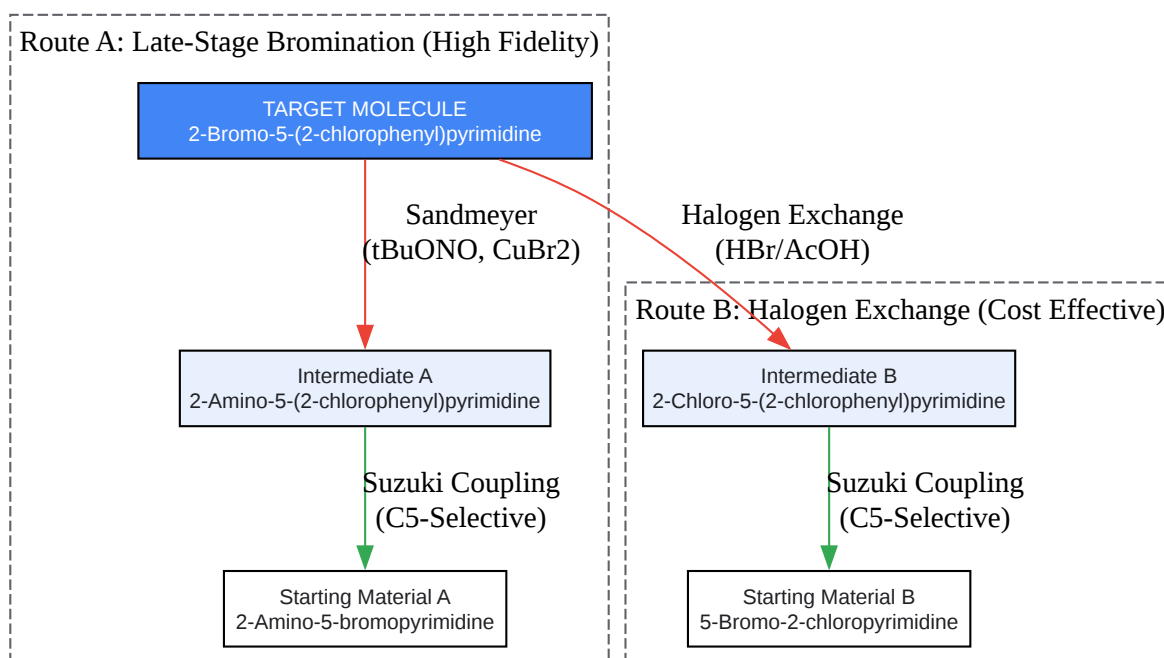

[Click to download full resolution via product page](#)

Figure 1: Retrosynthetic disconnection showing two viable pathways to the target.

Protocol A: The "Late-Stage Bromination" Route

Objective: Synthesize high-purity product by masking the C2-bromide as an amine during the coupling step.

Step 1: Suzuki-Miyaura Coupling

- Reaction: 2-Amino-5-bromopyrimidine + (2-Chlorophenyl)boronic acid

2-Amino-5-(2-chlorophenyl)pyrimidine.

- Rationale: The free amine at C2 poisons the catalyst less than a halide and is inert to the coupling conditions. The coupling occurs exclusively at the C5-Br.

Materials:

- 2-Amino-5-bromopyrimidine (1.0 equiv)
- (2-Chlorophenyl)boronic acid (1.2 equiv)
- Catalyst: Pd(dppf)Cl
·DCM (3-5 mol%) - Selected for stability and ability to handle steric bulk.
- Base: K
CO
(2.5 equiv)
- Solvent: 1,4-Dioxane / Water (4:1 ratio)

Procedure:

- Charge a reaction flask with 2-amino-5-bromopyrimidine (10.0 mmol, 1.74 g), boronic acid (12.0 mmol, 1.88 g), and K
CO
(25.0 mmol, 3.45 g).
- Add 1,4-Dioxane (40 mL) and Water (10 mL). Degas by sparging with Nitrogen for 15 minutes.
- Add Pd(dppf)Cl
·DCM (0.3 mmol, 245 mg).
- Heat to 90°C for 12-16 hours under Nitrogen.
- Workup: Cool to RT. Dilute with EtOAc and water. Separate layers. Wash organic layer with brine, dry over Na
SO
, and concentrate.

- Purification: Recrystallize from Ethanol or flash chromatography (EtOAc/Hexane gradient).
 - Expected Yield: 80-90%.[\[2\]](#)

Step 2: Non-Aqueous Sandmeyer (Bromo-deamination)

- Reaction: 2-Amino-5-(2-chlorophenyl)pyrimidine

2-Bromo-5-(2-chlorophenyl)pyrimidine.

- Rationale: Standard aqueous Sandmeyer conditions (NaNO

/HBr) often fail with heterocyclic amines due to solubility issues and side reactions. The Doyle method (Alkyl nitrite + CuBr

) in organic solvent is superior for pyrimidines.

Materials:

- Intermediate from Step 1 (1.0 equiv)[\[3\]](#)[\[4\]](#)
- Reagent: tert-Butyl Nitrite (tBuONO) (1.5 equiv)
- Bromine Source: CuBr
(1.2 equiv)
- Solvent: Acetonitrile (Anhydrous)

Procedure:

- Suspend CuBr
(1.2 equiv) in anhydrous Acetonitrile (0.2 M concentration relative to substrate) in a dry flask under Nitrogen.
- Add tert-Butyl Nitrite (1.5 equiv) dropwise. The mixture may turn dark.
- Add the 2-Amino-5-(2-chlorophenyl)pyrimidine (1.0 equiv) portion-wise or as a solution in minimal Acetonitrile.

- Caution: Nitrogen gas evolution will occur.
- Stir at Room Temperature for 2 hours, then heat to 60°C for 1 hour to ensure completion.
- Workup: Quench with 10% HCl (aq) to solubilize copper salts. Extract with DCM.[5] Wash organic layer with saturated NaHCO₃ (to remove acid) and brine.
- Purification: Flash chromatography (0-20% EtOAc in Hexanes).
 - Target Yield: 65-75%.

Protocol B: The "Halogen Exchange" Route

Objective: Utilize cost-effective starting materials for larger scale synthesis.

Step 1: Regioselective Suzuki Coupling

- Reaction: 5-Bromo-2-chloropyrimidine + (2-Chlorophenyl)boronic acid
2-Chloro-5-(2-chlorophenyl)pyrimidine.
- Rationale: The C5-Br bond is more reactive towards oxidative addition than the C2-Cl bond under standard Suzuki conditions, despite the electron deficiency of C2.

Materials:

- 5-Bromo-2-chloropyrimidine (1.0 equiv)[1][6]
- (2-Chlorophenyl)boronic acid (1.05 equiv) - Keep stoichiometry tight to prevent bis-coupling.
- Catalyst: Pd(PPh₃)₄ (2 mol%)
- Base: Na₂CO₃

CO

(2.0 equiv)

- Solvent: Toluene / Ethanol / Water (2:1:1)

Procedure:

- Dissolve 5-bromo-2-chloropyrimidine (20 mmol) and boronic acid (21 mmol) in Toluene (40 mL) and Ethanol (20 mL).

- Add aqueous Na

CO

(2M, 20 mL). Degas thoroughly.

- Add Pd(PPh

)

(0.4 mmol).

- Heat at 80°C for 4-6 hours. Monitor closely by TLC/LCMS to stop before C2-coupling occurs.
- Workup: Standard extraction with EtOAc.
- Purification: The product (2-Chloro intermediate) is less polar than the starting material. Purify by short silica plug.

Step 2: Halogen Exchange (Finkelstein-like)

- Reaction: 2-Chloro-5-(2-chlorophenyl)pyrimidine

2-Bromo-5-(2-chlorophenyl)pyrimidine.

- Rationale: HBr in Acetic Acid forces the equilibrium towards the bromide due to the higher nucleophilicity of bromide in this medium and the volatility of HCl.

Materials:

- 2-Chloro intermediate (1.0 equiv)[7]
- Reagent: HBr (33% wt in Glacial Acetic Acid) - Excess (10-20 equiv).

Procedure:

- Dissolve the 2-Chloro intermediate in HBr/AcOH solution (concentration ~0.5 M).
- Seal the vessel (pressure tube recommended) and heat to 80-90°C for 4-8 hours.
- Monitoring: Monitor by LCMS. The mass shift is +44 amu (Cl to Br).
- Workup: Pour onto ice/water. Neutralize carefully with solid Na

CO

or NaOH (exothermic!).

- Extract with DCM or EtOAc.
- Purification: Recrystallization from Hexanes/EtOAc.

Comparative Data & Troubleshooting

Feature	Protocol A (Amino/Sandmeyer)	Protocol B (Exchange)
Overall Yield	50-65%	40-55%
Purity Profile	High (Avoids regio-isomers)	Moderate (Risk of bis-coupling)
Cost	Moderate (Reagents)	Low (Starting Materials)
Scalability	Good (No pressure vessels)	Excellent (Fewer steps if optimized)
Key Risk	Diazo intermediate stability	HBr corrosivity / Pressure

Experimental Workflow Diagram

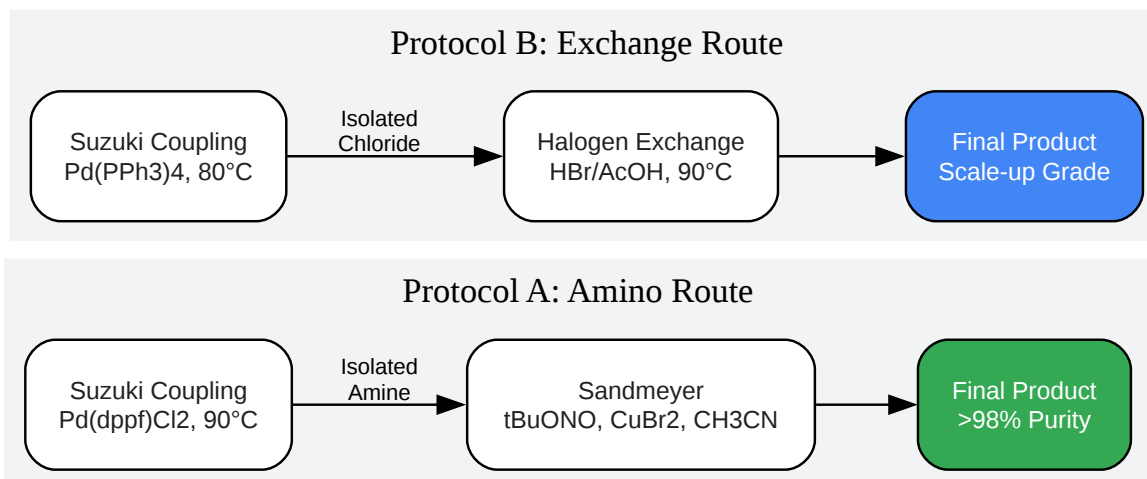

[Click to download full resolution via product page](#)

Figure 2: Operational workflow for both synthesis protocols.

References

- BenchChem. Application Notes: Suzuki-Miyaura Coupling of 5-Bromo-2-chloropyrimidine for Drug Discovery. Retrieved from
- GuideChem. How can 2-CHLORO-5-PHENYL-PYRIMIDINE be synthesized? Retrieved from
- Google Patents. EP1411048A1 - Preparation of 2-bromo-pyrimidines and 2-iodo-pyrimidines. (Describes HBr/AcOH exchange method). Retrieved from
- Heterocyclic Letters. A convenient and scalable process for preparation of 2,5-dibromopyridine.[2] (Describes Sandmeyer conditions). Retrieved from
- ResearchGate. Regioselective Suzuki-Miyaura cross-coupling reactions of heteroaryl halides. Retrieved from

Need Custom Synthesis?

BenchChem offers custom synthesis for rare earth carbides and specific isotopic labeling.

Email: info@benchchem.com or [Request Quote Online](#).

Sources

- [1. pdf.benchchem.com \[pdf.benchchem.com\]](https://pdf.benchchem.com)
- [2. heteroletters.org \[heteroletters.org\]](https://heteroletters.org)
- [3. pdfs.semanticscholar.org \[pdfs.semanticscholar.org\]](https://pdfs.semanticscholar.org)
- [4. beaudry.chem.oregonstate.edu \[beaudry.chem.oregonstate.edu\]](https://beaudry.chem.oregonstate.edu)
- [5. Regioselective palladium-catalyzed Suzuki–Miyaura coupling reaction of 2,4,6-trihalogenopyrido\[2,3-d\]pyrimidines \[comptes-rendus.academie-sciences.fr\]](https://comptes-rendus.academie-sciences.fr)
- [6. One-step synthesis method of 5-bromo-2-chloropyrimidine - Eureka | Patsnap \[eureka.patsnap.com\]](https://eureka.patsnap.com)
- [7. pdf.benchchem.com \[pdf.benchchem.com\]](https://pdf.benchchem.com)
- To cite this document: BenchChem. [Optimized Synthesis Protocols for 2-Bromo-5-(2-chlorophenyl)pyrimidine]. BenchChem, [2026]. [Online PDF]. Available at: [\[https://www.benchchem.com/product/b13981060/docs#optimized-synthesis-protocols-for-2-bromo-5-2-chlorophenyl-pyrimidine\]](https://www.benchchem.com/product/b13981060/docs#optimized-synthesis-protocols-for-2-bromo-5-2-chlorophenyl-pyrimidine)

Disclaimer & Data Validity:

The information provided in this document is for Research Use Only (RUO) and is strictly not intended for diagnostic or therapeutic procedures. While BenchChem strives to provide accurate protocols, we make no warranties, express or implied, regarding the fitness of this product for every specific experimental setup.

Technical Support: The protocols provided are for reference purposes. Unsure if this reagent suits your experiment?

Need Industrial/Bulk Grade? [Request Custom Synthesis Quote](#)

BenchChem

Our mission is to be the trusted global source of essential and advanced chemicals, empowering scientists and researchers to drive progress in science and industry.

Contact

Address: 3281 E Guasti Rd
Ontario, CA 91761, United States
Phone: (601) 213-4426
Email: info@benchchem.com

[Contact our Ph.D. Support Team for a compatibility check](#)