

Process Development Guide: Large-Scale Synthesis of Methyl 4-(2-methoxyacetyl)benzoate

Author: BenchChem Technical Support Team. **Date:** April 2026

Compound of Interest

Compound Name: *Methyl 4-(2-methoxyacetyl)benzoate*

Cat. No.: *B13980998*

[Get Quote](#)

Part 1: Executive Summary & Strategic Analysis[1] Scope and Application

This application note details a robust, scalable protocol for the synthesis of **Methyl 4-(2-methoxyacetyl)benzoate**, a critical intermediate in the manufacturing of p38 MAP kinase inhibitors and various antineoplastic agents.

While laboratory-scale methods often utilize diverse reagents, large-scale production requires a balance of atom economy, cost-efficiency, and safety.[1] This guide focuses on the industrial standard two-step sequence: alpha-bromination of methyl 4-acetylbenzoate followed by nucleophilic substitution with methanol.[1]

Retrosynthetic Logic

The synthesis is designed to avoid the use of expensive transition metal catalysts (e.g., Pd-catalyzed coupling) and highly reactive organolithium reagents that are incompatible with the ester moiety.

- **Route Selection:** Friedel-Crafts acylation of methyl benzoate is deactivated and regioselective poor.[1] Therefore, functionalization of the commercially available Methyl 4-acetylbenzoate is the preferred starting point.
- **Critical Challenge:** The primary impurity risk is the formation of the dibromo species during Step 1, which is difficult to separate from the monobromo intermediate.
- **Safety Critical:** The intermediate, Methyl 4-(2-bromoacetyl)benzoate, is a potent lachrymator (tear gas agent).[1] Engineering controls are mandatory.

Part 2: Detailed Experimental Protocols

Step 1: Alpha-Bromination of Methyl 4-acetylbenzoate[1]

Objective: Selective monobromination of the acetyl group. Reaction Type: Acid-catalyzed electrophilic halogenation.[1]

Reagents & Materials

Component	Equiv.	Role
Methyl 4-acetylbenzoate	1.0	Starting Material
Bromine ()	1.05	Brominating Agent
Acetic Acid (Glacial)	Solvent	Solvent/Catalyst
HBr (48% aq)	0.05	Initiator

Process Protocol

- **Dissolution:** Charge a glass-lined reactor with Methyl 4-acetylbenzoate (1.0 equiv) and Glacial Acetic Acid (5-8 volumes).
 - **Note:** Acetic acid promotes the enolization of the ketone, which is the active nucleophile reacting with bromine.
- **Initiation:** Add catalytic HBr (0.05 equiv) to shorten the induction period. Adjust jacket temperature to 20°C.

- Controlled Addition: Add Bromine (1.05 equiv) dropwise over 2–4 hours.
 - Critical Control: Maintain internal temperature between 20–25°C. Temperatures >30°C significantly increase the rate of dibromination (impurity).
 - Visual Check: The reaction is self-indicating; the deep red bromine color should dissipate as it reacts. If color accumulates, stop addition and wait for consumption.
- Quench & Isolation:
 - Cool the mixture to 10°C.
 - Add water (10 volumes) slowly to precipitate the product.
 - Filter the solid slurry.[\[2\]](#)[\[3\]](#)[\[4\]](#)
 - Wash the cake with cold water (2x) followed by cold 1:1 water/methanol to remove residual acid and colored impurities.
- Drying: Dry under vacuum at 40°C.
 - Target Yield: 85–90%
 - Intermediate: Methyl 4-(2-bromoacetyl)benzoate (CAS: 56893-25-5).[\[1\]](#)[\[5\]](#)

Step 2: Methanolysis (Nucleophilic Substitution)[\[1\]](#)

Objective: Displacement of the bromide by methoxide without hydrolyzing the benzoate ester.

Reaction Type:

Substitution.

Reagents & Materials

Component	Equiv.	Role
Bromo-Intermediate	1.0	Substrate
Methanol (Anhydrous)	10 Vol	Solvent/Reactant
Potassium Carbonate ()	1.5	Base / Acid Scavenger

Rationale: Using Sodium Methoxide (

) is risky as it is a strong enough base to cause transesterification or the Darzens reaction (epoxide formation). Potassium Carbonate is mild enough to buffer the HBr formed but weak enough to leave the ester and alpha-protons largely undisturbed.

Process Protocol

- Slurry Preparation: In a reactor, suspend Methyl 4-(2-bromoacetyl)benzoate (1.0 equiv) in Methanol (10 volumes).
- Base Addition: Add anhydrous Potassium Carbonate (1.5 equiv) powder.
 - Note: Use powder, not granules, to ensure rapid neutralization of HBr.
- Reaction: Heat the mixture to reflux (65°C) for 2–4 hours.
 - Monitor: HPLC should show <1% remaining bromide.
- Work-up:
 - Cool to room temperature.[\[6\]](#)
 - Filter off the inorganic salts (, excess).
 - Concentrate the filtrate under reduced pressure to ~20% volume.

- Crystallization/Isolation:
 - Add Ethyl Acetate and wash with water to remove residual salts.
 - Dry organic layer over

, filter, and concentrate.
 - Recrystallize from minimal hot Methanol or Hexane/Ethyl Acetate if high purity (>99%) is required.

Part 3: Process Safety & Engineering Controls[1]

Hazard Analysis: Phenacyl Bromides

The intermediate Methyl 4-(2-bromoacetyl)benzoate is a structural analog to phenacyl bromide, a historic chemical warfare agent (tear gas).[1]

- Engineering Control: All solids handling (weighing, charging, filtration) must occur within a HEPA-filtered isolator or a high-velocity fume hood.[1]
- Decontamination: Spills should be neutralized immediately with a solution of 10% Sodium Thiosulfate and dilute alkali, which cleaves the carbon-halogen bond.[1]
- PPE: Double nitrile gloves, full-face respirator (organic vapor/acid gas cartridge), and Tyvek suit are mandatory during Step 1 work-up.[1]

Part 4: Visualization of Workflows

Synthetic Pathway

The following diagram illustrates the chemical transformation and the critical decision nodes.

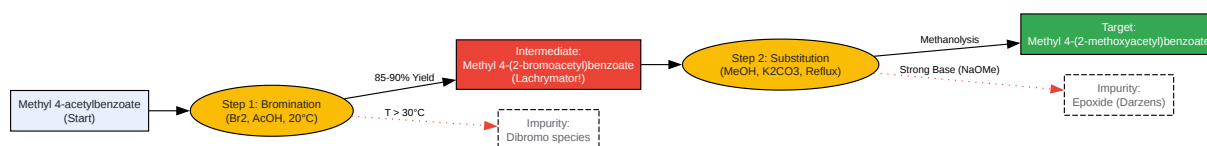

[Click to download full resolution via product page](#)

Caption: Figure 1. Reaction scheme highlighting critical process parameters (Temperature, Base Strength) to avoid impurities.

Process Flow Diagram (Unit Operations)

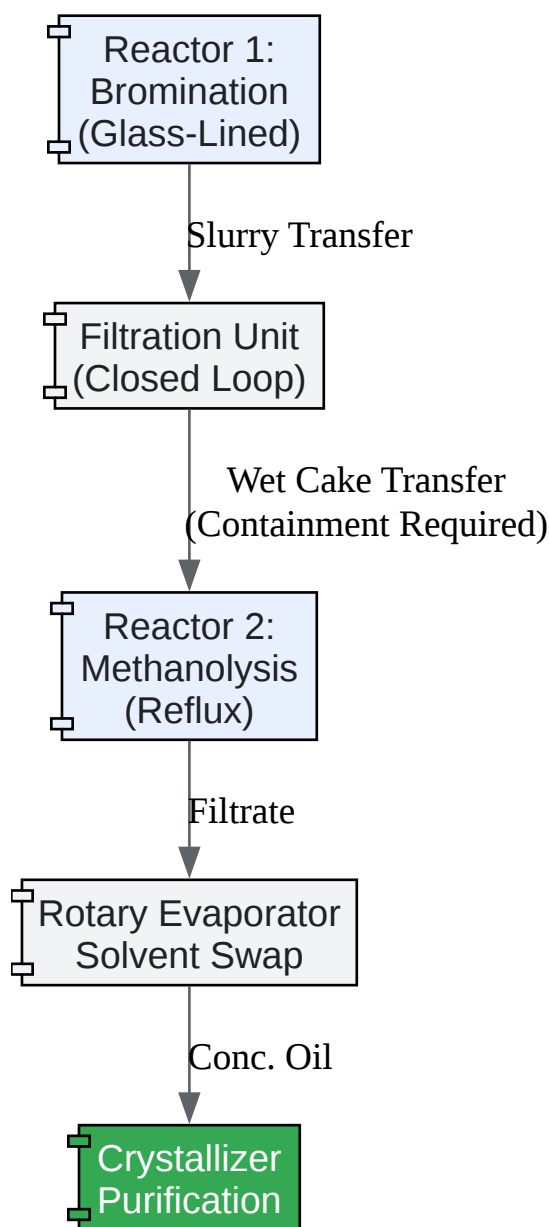

[Click to download full resolution via product page](#)

Caption: Figure 2. Unit operation flow emphasizing containment during the transfer of the lachrymatory intermediate.

Part 5: Analytical Specifications

To validate the process, the following quality attributes must be met:

Test	Method	Acceptance Criteria
Appearance	Visual	White to off-white crystalline solid
Assay	HPLC (C18, ACN/H2O)	> 98.0% (Area %)
Bromo-Intermediate	HPLC	< 0.5% (Process Safety Limit)
Identification	1H-NMR (CDCl3)	Distinct Singlet at 3.5 (OCH3), Singlet at 4.7 (CH2)

Part 6: References

- Vertex AI Search. (2025). Preparation of Methyl 4-(2-bromoacetyl)benzoate from methyl 4-acetylbenzoate. Retrieved from [7](#)
- Thermo Fisher Scientific. (2025).[8] Safety Data Sheet: Methyl 4-(bromomethyl)benzoate. Retrieved from [9](#)
- BenchChem. (2025). A Comparative Guide to the Synthesis of Substituted Phenacyl Bromides. Retrieved from [10](#)
- PubChem. (2025).[5][11][12] Methyl 4-(2-bromoacetyl)benzoate Compound Summary. Retrieved from [5](#)
- PrepChem. (2025). Synthesis of methyl 4-(2-bromoethoxy)benzoate (Analogous Methodology). Retrieved from [13](#)

Need Custom Synthesis?

BenchChem offers custom synthesis for rare earth carbides and specific isotopic labeling.

Email: info@benchchem.com or [Request Quote Online](#).

Sources

- [1. Methyl 4-acetamido-2-methoxybenzoate | lookchem \[lookchem.com\]](#)
- [2. Organic Syntheses Procedure \[orgsyn.org\]](#)
- [3. pdf.benchchem.com \[pdf.benchchem.com\]](#)
- [4. CN105418420A - Synthetic method of methyl 4-methoxyacetoacetate - Google Patents \[patents.google.com\]](#)
- [5. Methyl 4-\(2-bromoacetyl\)benzoate | C10H9BrO3 | CID 13612771 - PubChem \[pubchem.ncbi.nlm.nih.gov\]](#)
- [6. uomustansiriyah.edu.iq \[uomustansiriyah.edu.iq\]](#)
- [7. echemi.com \[echemi.com\]](#)
- [8. assets.thermofisher.com \[assets.thermofisher.com\]](#)
- [9. fishersci.com \[fishersci.com\]](#)
- [10. pdf.benchchem.com \[pdf.benchchem.com\]](#)
- [11. Methyl 4-\(acetylamino\)-2-methoxybenzoate | C11H13NO4 | CID 77720 - PubChem \[pubchem.ncbi.nlm.nih.gov\]](#)
- [12. 2-甲氧基-4-氨基苯甲酸甲酯 97% | Sigma-Aldrich \[sigmaaldrich.com\]](#)
- [13. prepchem.com \[prepchem.com\]](#)
- To cite this document: BenchChem. [Process Development Guide: Large-Scale Synthesis of Methyl 4-(2-methoxyacetyl)benzoate]. BenchChem, [2026]. [Online PDF]. Available at: [\[https://www.benchchem.com/product/b13980998/docs#process-development-guide-large-scale-synthesis-of-methyl-4-2-methoxyacetyl-benzoate\]](https://www.benchchem.com/product/b13980998/docs#process-development-guide-large-scale-synthesis-of-methyl-4-2-methoxyacetyl-benzoate)

Disclaimer & Data Validity:

The information provided in this document is for Research Use Only (RUO) and is strictly not intended for diagnostic or therapeutic procedures. While BenchChem strives to provide accurate protocols, we make no warranties, express or implied, regarding the fitness of this product for every specific experimental setup.

Technical Support: The protocols provided are for reference purposes. Unsure if this reagent suits your experiment?

Need Industrial/Bulk Grade? [Request Custom Synthesis Quote](#)

BenchChem

Our mission is to be the trusted global source of essential and advanced chemicals, empowering scientists and researchers to drive progress in science and industry.

Contact

Address: 3281 E Guasti Rd

Ontario, CA 91761, United States

Phone: (601) 213-4426

Email: info@benchchem.com

[Contact our Ph.D. Support Team for a compatibility check](#)