

# Introduction: A Trifunctional Scaffold for Advanced Drug Discovery

**Author:** BenchChem Technical Support Team. **Date:** May 2026

## Compound of Interest

Compound Name:	2,4-Dichloropyrimidine-5-sulfonyl chloride
CAS No.:	23920-08-3
Cat. No.:	B1368790

[Get Quote](#)

**2,4-Dichloropyrimidine-5-sulfonyl chloride** (CAS No. 23920-08-3) is a highly reactive, multi-functional building block of significant interest to researchers in medicinal chemistry and drug development. Possessing three distinct electrophilic sites—two chlorine atoms on the pyrimidine ring at positions 2 and 4, and a sulfonyl chloride moiety at position 5—this compound offers a versatile platform for the synthesis of complex molecular architectures. Its strategic importance lies in the differential reactivity of these sites, which enables chemists to perform sequential, site-selective modifications to build diverse compound libraries. The pyrimidine core is a well-established "privileged scaffold" in pharmacology, frequently found in FDA-approved drugs, particularly kinase inhibitors, due to its ability to form critical hydrogen bond interactions with enzyme active sites.<sup>[1][2]</sup> This guide provides an in-depth analysis of the synthesis, reactivity, and application of this potent synthetic intermediate.

## Physicochemical Properties

A summary of the key properties of **2,4-Dichloropyrimidine-5-sulfonyl chloride** is provided below. It is important to note that while basic identifiers are well-documented, specific

experimental physical data such as melting and boiling points are not readily available in reviewed literature. For context, data for the parent scaffold, 2,4-dichloropyrimidine, is included.

Property	Value	Source
CAS Number	23920-08-3	[3]
Molecular Formula	C <sub>4</sub> HCl <sub>2</sub> N <sub>2</sub> O <sub>2</sub> S	[4]
Molecular Weight	247.49 g/mol	[4]
Appearance	Presumed to be a solid, sensitive to moisture.	Inferred
Reference Melting Point	56-62 °C (for 2,4-Dichloropyrimidine)	[5]
Reference Boiling Point	101 °C at 23 mmHg (for 2,4-Dichloropyrimidine)	[5]

## Synthesis and Purification

The synthesis of **2,4-Dichloropyrimidine-5-sulfonyl chloride** is not commonly detailed in standard literature but can be logically derived from established chlorination procedures for analogous pyrimidine structures.[6][7] The most plausible route involves the exhaustive chlorination of a suitable precursor, such as uracil-5-sulfonic acid. This transformation converts the hydroxyl groups of the uracil tautomer into chlorides and the sulfonic acid into the target sulfonyl chloride. A combination of phosphorus oxychloride (POCl<sub>3</sub>) and phosphorus pentachloride (PCl<sub>5</sub>) is a robust and effective reagent system for this type of transformation.[8]

## Proposed Synthetic Workflow

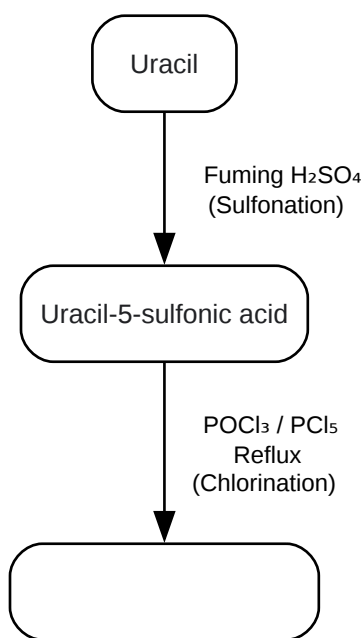

[Click to download full resolution via product page](#)

Caption: Proposed two-step synthesis of the title compound from uracil.

## Detailed Experimental Protocol (Chlorination Step)

Causality: This protocol utilizes a powerful chlorinating mixture ( $\text{POCl}_3/\text{PCl}_5$ ) capable of converting all three acidic functional groups (two enolic hydroxyls and one sulfonic acid) to their corresponding chlorides in a single operation.[6][8] The procedure must be conducted under strictly anhydrous conditions as all reagents and the product are highly sensitive to moisture.

- **Reactor Setup:** In a fume hood, equip a three-neck round-bottom flask with a reflux condenser, a nitrogen inlet, and a dropping funnel. Ensure all glassware is flame-dried and assembled under a positive pressure of inert gas (Nitrogen or Argon).
- **Reagent Charging:** To the flask, add uracil-5-sulfonic acid (1.0 eq) followed by phosphorus oxychloride ( $\text{POCl}_3$ , ~5-10 vol). Begin stirring to create a suspension.
- **Addition of  $\text{PCl}_5$ :** Carefully add phosphorus pentachloride ( $\text{PCl}_5$ , ~2.5-3.0 eq) portion-wise to the stirred suspension. The addition may be exothermic.
- **Reaction:** Heat the reaction mixture to reflux (approx. 105-110 °C) and maintain for 4-6 hours. The reaction progress can be monitored by quenching a small aliquot and analyzing

via LC-MS or  $^1\text{H}$  NMR to observe the disappearance of the starting material. The reaction mixture should become a clearer, homogenous solution.

- Work-up:
  - Cool the reaction mixture to room temperature. Carefully remove the excess  $\text{POCl}_3$  under reduced pressure using a rotary evaporator equipped with a base trap (e.g., NaOH solution) to neutralize the corrosive vapors.
  - Critical Step: Cool the viscous residue in an ice bath. Very slowly and cautiously, pour the residue onto crushed ice with vigorous stirring. This quenching step is highly exothermic and releases HCl gas. Perform this in a well-ventilated fume hood.
  - The product should precipitate as a solid or oil. Extract the aqueous mixture three times with a suitable organic solvent (e.g., dichloromethane or ethyl acetate).
- Purification:
  - Combine the organic layers, wash with cold brine, and dry over anhydrous sodium sulfate ( $\text{Na}_2\text{SO}_4$ ).
  - Filter the drying agent and concentrate the solvent in vacuo.
  - The crude product can be purified by vacuum distillation or flash column chromatography on silica gel, though care must be taken to minimize exposure to moisture.

## Reactivity and Mechanistic Insights: A Hierarchy of Electrophiles

The synthetic power of **2,4-Dichloropyrimidine-5-sulfonyl chloride** stems from the predictable, differential reactivity of its three electrophilic centers. Understanding this hierarchy is crucial for designing selective synthetic sequences.

- Sulfonyl Chloride ( $-\text{SO}_2\text{Cl}$ ): This is the most electrophilic and reactive site on the molecule. It will react rapidly with a wide range of nucleophiles, particularly primary and secondary amines, to form stable sulfonamides. This reaction can typically be performed at low

temperatures (e.g., 0 °C to room temperature) in the presence of a non-nucleophilic base (like triethylamine or DIPEA) to neutralize the HCl byproduct.

- C4-Chloride: The chlorine at the C4 position is highly activated towards nucleophilic aromatic substitution ( $S_NAr$ ). The pyrimidine nitrogens and the potent electron-withdrawing sulfonyl group at C5 work in concert to lower the electron density at C4, making it highly susceptible to attack.[9][10]  $S_NAr$  reactions at this position generally require more forcing conditions (e.g., elevated temperatures) than the sulfonamide formation.
- C2-Chloride: The chlorine at the C2 position is the least reactive of the three sites. While still activated by the ring nitrogens, it is less so than the C4-Cl.[11] Substitution at this position typically requires harsh conditions (high temperatures, strong nucleophiles) and often occurs only after the C4 position has been functionalized.

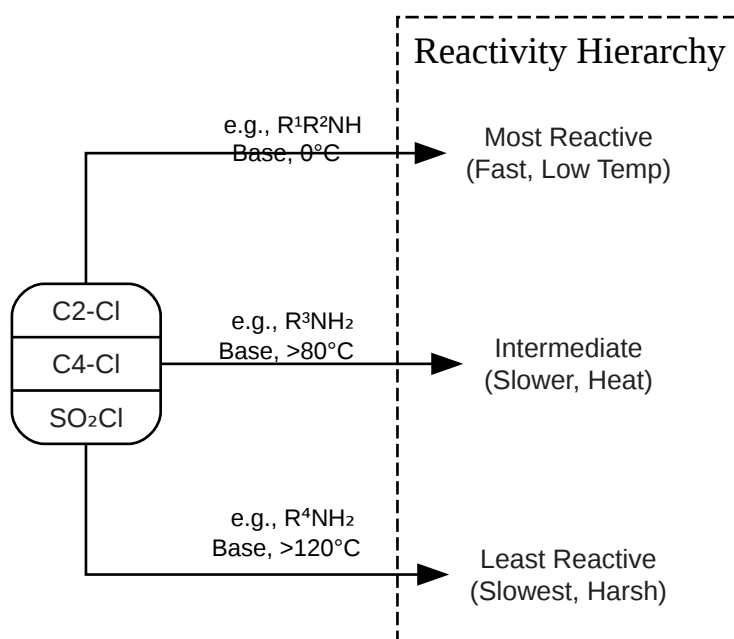

[Click to download full resolution via product page](#)

Caption: Reactivity hierarchy of the three electrophilic sites.

This predictable selectivity allows for a stepwise functionalization, which is a cornerstone of modern library synthesis for drug discovery.

## Core Applications in Drug Discovery: Building Kinase Inhibitors

The 2,4-disubstituted pyrimidine scaffold is a quintessential "hinge-binding" motif found in a vast number of ATP-competitive kinase inhibitors.[1] The nitrogen atoms of the pyrimidine ring act as hydrogen bond acceptors, mimicking the adenine portion of ATP and anchoring the inhibitor in the enzyme's active site. **2,4-Dichloropyrimidine-5-sulfonyl chloride** is an ideal starting material for rapidly accessing libraries of such inhibitors.

### General Workflow for Kinase Inhibitor Synthesis

The following workflow demonstrates how the differential reactivity can be exploited to build a molecule with three points of diversity ( $R^1$ ,  $R^2$ ,  $R^3$ ).

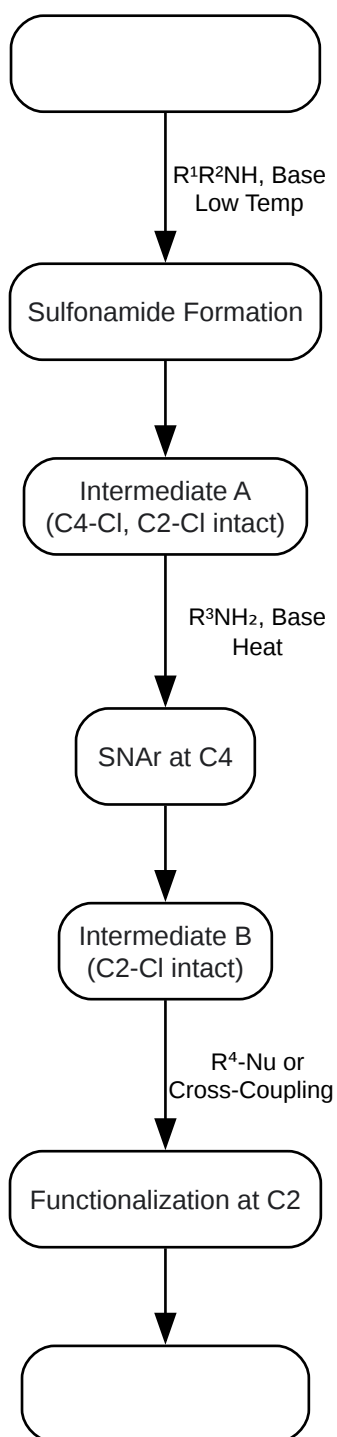

[Click to download full resolution via product page](#)

Caption: Stepwise workflow for synthesizing a kinase inhibitor library.

## Representative Protocol: Sequential Amination

- Sulfonamide Synthesis (Step 1):

- Dissolve **2,4-Dichloropyrimidine-5-sulfonyl chloride** (1.0 eq) in an anhydrous aprotic solvent like dichloromethane (DCM) or tetrahydrofuran (THF) under a nitrogen atmosphere.
- Cool the solution to 0 °C in an ice bath.
- Add a non-nucleophilic base (e.g., triethylamine, 1.5 eq).
- Slowly add a solution of the desired primary or secondary amine ( $R^1R^2NH$ , 1.1 eq) in the same solvent.
- Allow the reaction to warm to room temperature and stir for 2-4 hours, monitoring by TLC or LC-MS.
- Upon completion, perform a standard aqueous work-up to isolate the monosubstituted sulfonamide (Intermediate A).
- C4-Amine Substitution (Step 2):
  - Dissolve Intermediate A (1.0 eq) in a high-boiling point solvent such as n-butanol or N,N-dimethylformamide (DMF).
  - Add the second amine ( $R^3NH_2$ , 1.2 eq) and a base (e.g., DIPEA, 2.0 eq).
  - Heat the reaction mixture to 80-120 °C and stir for 6-24 hours. Monitor the reaction for the consumption of Intermediate A.
  - After cooling, the product (Intermediate B) is typically isolated by precipitation upon addition of water or by extraction and purification via column chromatography.

## Safety, Handling, and Storage

As a reactive chemical, **2,4-Dichloropyrimidine-5-sulfonyl chloride** must be handled with appropriate precautions. While a specific safety data sheet (SDS) is not widely available, the hazards can be reliably inferred from its functional groups and data on analogous compounds.

[12][13]

Hazard Class	Classification	Notes
Acute Toxicity, Oral	Warning (Harmful if swallowed)	Inferred from[13]
Skin Corrosion/Irritation	Warning (Causes skin irritation)	Inferred from[12]
Eye Damage/Irritation	Warning (Causes serious eye irritation)	Inferred from[12][13]
Reactivity	Reacts with water	Sulfonyl chlorides hydrolyze to the corresponding sulfonic acid, releasing corrosive HCl gas.

- Personal Protective Equipment (PPE): Always wear a lab coat, chemical-resistant gloves (e.g., nitrile), and chemical safety goggles. All manipulations should be performed in a certified chemical fume hood.
- Handling Procedures: Use spark-proof tools and maintain an inert atmosphere (nitrogen or argon) to prevent hydrolysis.[14] Avoid inhalation of dust or vapors. Avoid contact with skin and eyes.
- Storage: Store in a tightly sealed container under an inert atmosphere.[14] Keep in a cool, dry, and well-ventilated place away from water, bases, and alcohols.
- Disposal: Dispose of contents and container in accordance with local, state, and federal regulations. Unused material should be carefully quenched with a suitable nucleophile (e.g., a solution of sodium sulfite or an alcohol) before disposal.

## Conclusion

**2,4-Dichloropyrimidine-5-sulfonyl chloride** is a powerful and versatile synthetic intermediate that provides an efficient entry point to novel and complex heterocyclic compounds. Its well-defined hierarchy of reactivity enables chemists to execute controlled, sequential reactions, making it an invaluable tool in the construction of compound libraries for drug discovery, particularly in the field of kinase inhibitors. A thorough understanding of its reactivity, combined

with strict adherence to safety and handling protocols, allows researchers to fully exploit the synthetic potential of this potent building block.

## References

- XiXisys. (n.d.). GHS 11 (Rev.11) SDS Word 下载CAS: 23920-08-3 Name:. Retrieved January 18, 2026, from [\[Link\]](#)
- Wai, J. S., et al. (n.d.). Understanding the highly variable Regioselectivity in SNAr reaction of Dichloropyrimidines. CompuChem. Retrieved January 18, 2026, from [\[Link\]](#)
- Lu, Y., et al. (n.d.). Dichotomy in Regioselectivity of SNAr Reactions with 2-MeSO<sub>2</sub>-4-Chloropyrimidine. CompuChem. Retrieved January 18, 2026, from [\[Link\]](#)
- Chemsrvc. (2025). CAS#:23920-08-3 | **2,4-dichloropyrimidine-5-sulfonyl chloride**. Retrieved January 18, 2026, from [\[Link\]](#)
- St. John-Campbell, S., et al. (2024). Inverting the Conventional Site Selectivity of Cross-Coupling of 2,4-Dichloropyrimidines. Synlett.
- Lee, M., et al. (2015). Regioselective Control of the SNAr Amination of 5-Substituted-2,4-Dichloropyrimidines Using Tertiary Amine Nucleophiles. *The Journal of Organic Chemistry*, 80(15), 7757–7763.
- Google Patents. (n.d.). CN108117523B - Preparation method of halogenated uracil compound.
- Covestro. (n.d.). SAFETY DATA SHEET. Retrieved January 18, 2026, from [\[Link\]](#)
- Chen, L., et al. (2009). 2,4-Dichloropyrimidine. *Acta Crystallographica Section E: Structure Reports Online*, 65(7), o1438.
- Google Patents. (n.d.). US3561005A - Process for the production of 2,4-dichloropyrimidine-5-carboxylic acid chloride.
- Amin, S., et al. (2020). A review on synthetic procedures and applications of phosphorus oxychloride (POCl<sub>3</sub>) in the last biennial period (2018–19).
- Wai, J. S., et al. (n.d.). Understanding the highly variable Regioselectivity in SNAr reaction of Dichloropyrimidines. CompuChem. Retrieved January 18, 2026, from [\[Link\]](#)

- ResearchGate. (n.d.). Highly Regioselective Organocatalytic SNAr Amination of 2,4-Dichloropyrimidine and Related Heteroaryl Chlorides. Retrieved January 18, 2026, from [\[Link\]](#)
- MDPI. (2021). Synthesis of Novel 2-Thiouracil-5-Sulfonamide Derivatives as Potent Inducers of Cell Cycle Arrest and CDK2A Inhibition Supported by Molecular Docking. Retrieved January 18, 2026, from [\[Link\]](#)
- Scott, J. S., et al. (2022). Discovery and Characterization of a Novel Series of Chloropyrimidines as Covalent Inhibitors of the Kinase MSK1. ACS Medicinal Chemistry Letters, 13(6), 947-953.
- Ted Pella, Inc. (2017). Safety Data Sheet Product No. 19920 PELCO® Pro Cyanoacrylate Debonder. Retrieved January 18, 2026, from [\[Link\]](#)
- National Center for Biotechnology Information. (n.d.). 2,4-Dichloropyrimidine. PubChem. Retrieved January 18, 2026, from [\[Link\]](#)
- National Center for Biotechnology Information. (n.d.). 2,4-Dichloropyrimidine-5-carboxamide. PubChem. Retrieved January 18, 2026, from [\[Link\]](#)
- Wang, Y., et al. (2023). Design, synthesis and biological evaluation of 2-((4-sulfamoylphenyl)amino)-pyrrolo[2,3-d]pyrimidine derivatives as CDK inhibitors. Bioorganic & Medicinal Chemistry Letters, 79, 129088.
- Studylib. (n.d.). 2,4-Dichloropyrimidine: Reactions & Applications in Organic Chemistry. Retrieved January 18, 2026, from [\[Link\]](#)...
- Trilleras, J., et al. (2022). SNAr Reactions on 2-Amino-4,6-dichloropyrimidine-5-carbaldehyde. Molbank, 2022(3), M1453.
- Google Patents. (n.d.). ES2203361T3 - PROCEDURE FOR THE PREPARATION OF CHLORINE PRIRIDINSULPHONIC ACID CHLORIDES.
- Britton, T. C., et al. (2018). Aqueous Process Chemistry: The Preparation of Aryl Sulfonyl Chlorides. Organic Process Research & Development, 22(9), 1275-1280.
- Indian Chemical Society. (n.d.). POCl<sub>3</sub>-PCl<sub>5</sub> mixture: A robust chlorinating agent. Retrieved January 18, 2026, from [\[Link\]](#)

- Marchetti, F., et al. (n.d.). Revisitation of the  $\text{PCl}_5$ -Chlorination Reaction of  $\alpha$ -Amino Acids: Spectroscopic and DFT Insights, and Synthesis of the L-Proline. University of Pisa. Retrieved January 18, 2026, from [\[Link\]](#)

### Need Custom Synthesis?

BenchChem offers custom synthesis for rare earth carbides and specific isotopic labeling.

Email: [info@benchchem.com](mailto:info@benchchem.com) or [Request Quote Online](#).

## Sources

- 1. Inverting the Conventional Site Selectivity of Cross-Coupling of 2,4-Dichloropyrimidines - PMC [[pmc.ncbi.nlm.nih.gov](https://pubmed.ncbi.nlm.nih.gov)]
- 2. [pdf.benchchem.com](https://pdf.benchchem.com) [[pdf.benchchem.com](https://pdf.benchchem.com)]
- 3. CAS#:23920-08-3 | 2,4-dichloropyrimidine-5-sulfonyl chloride | Chemsrvc [[chemsrc.com](https://chemsrc.com)]
- 4. 2,4-DICHLOROPYRIMIDINE-5-SULFONYL CHLORIDE CAS#: 23920-08-3 [[m.chemicalbook.com](https://m.chemicalbook.com)]
- 5. [chemimpex.com](https://chemimpex.com) [[chemimpex.com](https://chemimpex.com)]
- 6. US3561005A - Process for the production of 2,4-dichloropyrimidine - 5-carboxylic acid chloride - Google Patents [[patents.google.com](https://patents.google.com)]
- 7. Synthesis of Novel 2-Thiouracil-5-Sulfonamide Derivatives as Potent Inducers of Cell Cycle Arrest and CDK2A Inhibition Supported by Molecular Docking | MDPI [[mdpi.com](https://mdpi.com)]
- 8. [indianchemicalsociety.com](https://indianchemicalsociety.com) [[indianchemicalsociety.com](https://indianchemicalsociety.com)]
- 9. Regioselective Control of the  $\text{S}_{\text{N}}\text{Ar}$  Amination of 5-Substituted-2,4-Dichloropyrimidines Using Tertiary Amine Nucleophiles - PubMed [[pubmed.ncbi.nlm.nih.gov](https://pubmed.ncbi.nlm.nih.gov)]
- 10. [pdf.benchchem.com](https://pdf.benchchem.com) [[pdf.benchchem.com](https://pdf.benchchem.com)]
- 11. [wuxibiology.com](https://wuxibiology.com) [[wuxibiology.com](https://wuxibiology.com)]
- 12. 2,4-Dichloropyrimidine |  $\text{C}_4\text{H}_2\text{Cl}_2\text{N}_2$  | CID 77531 - PubChem [[pubchem.ncbi.nlm.nih.gov](https://pubchem.ncbi.nlm.nih.gov)]
- 13. 2,4-Dichloropyrimidine-5-carboxamide |  $\text{C}_5\text{H}_3\text{Cl}_2\text{N}_3\text{O}$  | CID 21223080 - PubChem [[pubchem.ncbi.nlm.nih.gov](https://pubchem.ncbi.nlm.nih.gov)]
- 14. [tedpella.com](https://tedpella.com) [[tedpella.com](https://tedpella.com)]

- To cite this document: BenchChem. [Introduction: A Trifunctional Scaffold for Advanced Drug Discovery]. BenchChem, [2026]. [Online PDF]. Available at: [<https://www.benchchem.com/product/b1368790/docs#introduction-a-trifunctional-scaffold-for-advanced-drug-discovery>]

---

### Disclaimer & Data Validity:

The information provided in this document is for Research Use Only (RUO) and is strictly not intended for diagnostic or therapeutic procedures. While BenchChem strives to provide accurate protocols, we make no warranties, express or implied, regarding the fitness of this product for every specific experimental setup.

**Technical Support:** The protocols provided are for reference purposes. Unsure if this reagent suits your experiment?

**Need Industrial/Bulk Grade?** [Request Custom Synthesis Quote](#)

## BenchChem

Our mission is to be the trusted global source of essential and advanced chemicals, empowering scientists and researchers to drive progress in science and industry.

### Contact

Address: 3281 E Guasti Rd  
Ontario, CA 91761, United States  
Phone: (601) 213-4426  
Email: [info@benchchem.com](mailto:info@benchchem.com)

[Contact our Ph.D. Support Team for a compatibility check](#)