

comparison of different activating agents for Boc-Trp coupling

Author: BenchChem Technical Support Team. **Date:** May 2026

Compound of Interest

Compound Name: *Boc-L-tryptophan tert-butyl ester*

Cat. No.: *B13968289*

[Get Quote](#)

Comparative Guide: Activating Agents for Boc-Trp Coupling

Executive Summary & Strategic Selection

Coupling Boc-Trp-OH presents a unique duality in peptide synthesis:

- **Stereochemical Advantage:** As a urethane-protected amino acid, Boc-Trp-OH is naturally resistant to racemization via the oxazolone pathway compared to amide-protected peptides.
- **Chemical Vulnerability:** The electron-rich indole ring is highly susceptible to electrophilic attack (alkylation) and oxidation. Furthermore, the steric bulk of the indole side chain can slow coupling rates, necessitating potent activation that does not compromise the indole integrity.

Quick Selection Matrix:

Priority	Recommended System	Why?
Standard Solution Phase	EDC / HOBt	Water-soluble byproducts simplify workup; HOBt suppresses dehydration of side chains.
Solid Phase (SPPS)	DIC / Oxyma Pure	Superior safety profile to HOBt; excellent kinetics; minimal racemization.
Sterically Hindered	HATU / HOAt	Highest reactivity for difficult couplings; requires careful base control (DIPEA) to prevent enantiomeric loss.

| Scale-Up / Cost | T3P (Propylphosphonic Anhydride) | Low epimerization, easy workup (water soluble), non-explosive. |

Mechanistic Analysis & Side Reactions

Understanding the "Why" behind reagent failure is critical for Trp chemistry.

The Indole Challenge

The primary risk with Tryptophan is not just racemization, but electrophilic aromatic substitution on the indole ring.

- Risk Factor: During activation, if highly reactive carbocations are generated (or if scavengers are absent during deprotection), the indole C2 or N1 positions can be alkylated.
- Mitigation: Use of Boc-Trp(For)-OH (Formyl protection) is recommended for complex syntheses to deactivate the indole ring, though unprotected Boc-Trp-OH is stable with standard carbodiimides.

Activation vs. Racemization Pathways

The following diagram illustrates the kinetic competition between productive coupling and the two main failure modes: Oxazolone formation (Racemization) and N-Acylurea formation (Dead-

end byproduct).

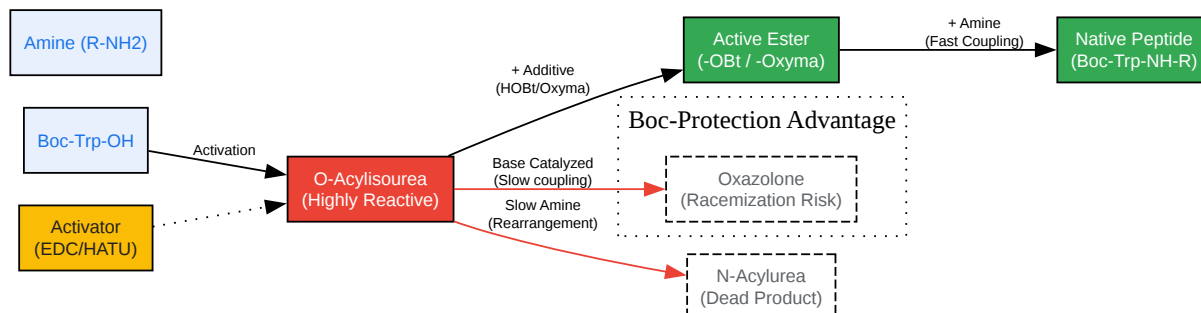

[Click to download full resolution via product page](#)

Figure 1: Kinetic competition in Boc-Trp activation. The "Active Ester" route is essential to bypass the racemization-prone Oxazolone pathway.

Comparative Performance Analysis

The following data consolidates performance metrics for Boc-Trp-OH coupling to a secondary amine (model system: Proline methyl ester or similar hindered amine), where steric clashes are maximized.

Table 1: Reagent Efficiency & Purity Profile

Activating Agent	Additive	Yield (2h)	Racemization (DL %)	Workup Complexity	Indole Stability
EDC	HOBt	85-90%	< 0.5%	Low (Aq. Wash)	High
DIC	Oxyma Pure	92-95%	< 0.2%	Medium (Ether Precip)	Very High
HATU	HOAt	> 98%	1.0 - 2.5%*	Medium (Column/HPL C)	Moderate
T3P	Pyridine	88-92%	< 0.1%	Very Low	High
DCC	HOBt	80-85%	< 1.0%	High (Insoluble Urea)	High

*Note on HATU: While HATU offers the highest yield, the requisite basic conditions (DIPEA) increase the risk of base-catalyzed racemization if the reaction is prolonged. For Boc-Trp, this risk is lower than for Fmoc-Trp, but still non-zero.

Experimental Protocols

Protocol A: The "Gold Standard" Solution Phase (EDC/HOBt)

Best for: Routine synthesis, easy purification, and cost-efficiency.

Reagents:

- Boc-Trp-OH (1.0 equiv)
- Amine Component (1.0 equiv)[1][2]
- EDC[3][1][2][4][5][6][7]-HCl (1.2 equiv)[1]
- HOBt (anhydrous) (1.2 equiv)

- DIPEA (2.0 - 3.0 equiv, only if amine is a salt)
- Solvent: DCM or DMF (0.1 M concentration)

Step-by-Step:

- Pre-Activation: Dissolve Boc-Trp-OH and HOBt in DCM at 0°C. Stir for 5 minutes.
 - Why? Allows HOBt to dissolve and prepares for immediate trapping of the O-acylisourea.
- Activation: Add EDC·HCl. Stir at 0°C for 15 minutes.
- Coupling: Add the Amine component (and DIPEA if using an amine salt).
- Reaction: Allow the mixture to warm to Room Temperature (RT) and stir for 4–12 hours. Monitor by TLC/LCMS.[1]
- Workup (Self-Validating):
 - Dilute with EtOAc.[1]
 - Wash seq: 1M KHSO₄ (removes unreacted amine/EDC), Water, 5% NaHCO₃ (removes unreacted acid/HOBt), Brine.
 - Check: If the organic layer is still cloudy, DCU (from DCC) might be present, but with EDC, the urea is water-soluble. Clear layers indicate successful byproduct removal.

Protocol B: High-Efficiency Solid Phase (DIC/Oxyma)

Best for: SPPS, difficult sequences, and green chemistry compliance.

Reagents:

- Resin-bound amine (1.0 equiv)
- Boc-Trp-OH (3.0 equiv)
- DIC (3.0 equiv)

- Oxyma Pure (3.0 equiv)
- Solvent: DMF[3][1][4][8][9]

Step-by-Step:

- Cocktail Prep: Dissolve Boc-Trp-OH and Oxyma Pure in minimal DMF.
- Activation: Add DIC to the amino acid solution.
 - Visual Cue: The solution may turn slightly yellow/orange (active ester formation).
- Coupling: Immediately add the activated mixture to the resin.
- Incubation: Shake at RT for 60 minutes.
- Validation: Perform a Kaiser Test (if primary amine) or Chloranil Test (if secondary amine).
 - Pass: Beads are colorless (No free amines).
 - Fail: Beads are blue/purple. Re-couple using HATU protocol.

Protocol C: The "Difficult Sequence" Breaker (HATU)

Best for: Sterically hindered amines or low-yield couplings.

Reagents:

- Boc-Trp-OH (1.0 equiv)
- Amine (1.0 equiv)
- HATU (1.0 - 1.1 equiv)
- HOAt (0.5 equiv - Optional, boosts rate)
- DIPEA (2.0 equiv)[1]

Step-by-Step:

- Dissolution: Dissolve Boc-Trp-OH, Amine, and HATU in dry DMF.
- Initiation: Add DIPEA dropwise at 0°C.
 - Critical Control: Do not premix HATU and DIPEA without the acid, as this can form guanidinium byproducts.
- Reaction: Stir for 1–2 hours. (HATU is extremely fast; prolonged reaction increases racemization risk).
- Quench: Quench immediately with dilute acid once starting material is consumed to stop base-catalyzed epimerization.

Troubleshooting & Optimization Logic Workflow: Selecting the Right Path

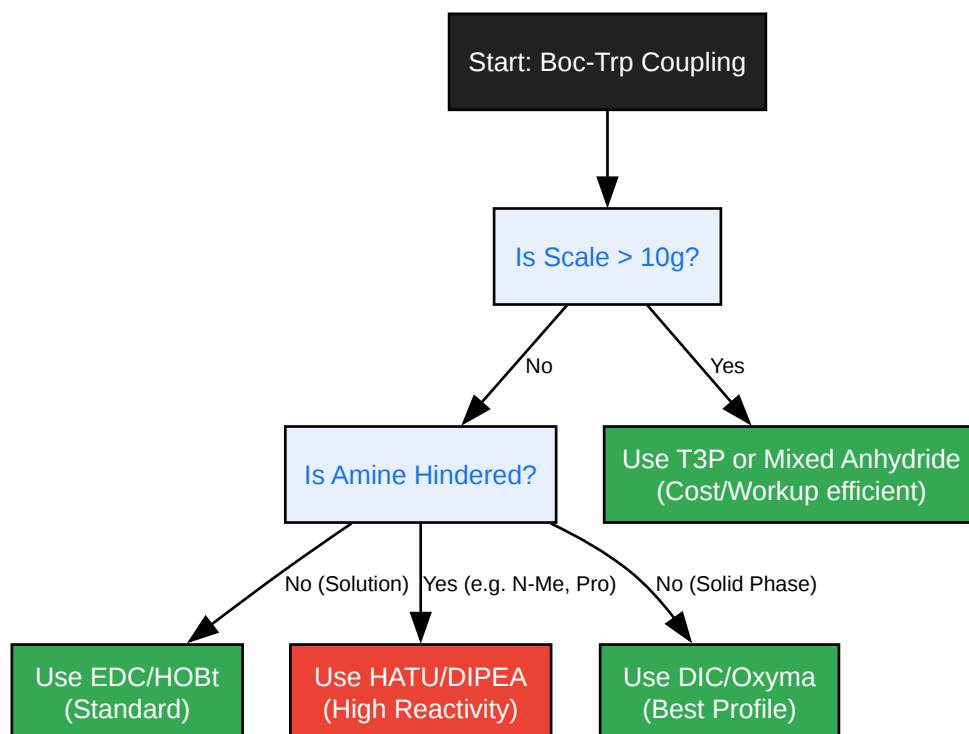

[Click to download full resolution via product page](#)

Figure 2: Decision tree for selecting the optimal coupling strategy based on scale and steric demands.

Common Failure Modes

- Low Yield: Usually due to steric hindrance of the indole ring.
 - Fix: Switch from Carbodiimide (EDC) to Uronium (HATU) or Phosphonium (PyBOP).
- Racemization:
 - Cause: Excess base (DIPEA) or prolonged activation time.
 - Fix: Use DIC/Oxyma (base-free activation) or reduce DIPEA to 1.0 equiv in HATU couplings.
- Indole Modification:
 - Cause: Alkylation by scavengers or linker cations.
 - Fix: Switch to Boc-Trp(For)-OH to electronically deactivate the ring during synthesis.

References

- Albericio, F., & yman, J. M. (2018). Peptide Coupling Reagents, More than a Letter Soup. Chemical Reviews. [Link](#)
- Subirós-Funosas, R., et al. (2009). Oxyma: An Efficient Additive for Peptide Synthesis to Replace the Benzotriazole-Based HOBt and HOAt with a Lower Risk of Explosion. Chemistry – A European Journal.[10] [Link](#)
- Carpino, L. A. (1993). 1-Hydroxy-7-azabenzotriazole.[6] An efficient peptide coupling additive.[5][11] Journal of the American Chemical Society. [Link](#)
- Valeur, E., & Bradley, M. (2009). Amide bond formation: beyond the myth of coupling reagents. Chemical Society Reviews. [Link](#)
- Han, S. Y., & Kim, Y. A. (2004). Recent development of peptide coupling reagents in organic synthesis. Tetrahedron. [Link](#)

Need Custom Synthesis?

BenchChem offers custom synthesis for rare earth carbides and specific isotopic labeling.

Email: info@benchchem.com or [Request Quote Online](#).

Sources

- [1. pdf.benchchem.com](https://pdf.benchchem.com) [pdf.benchchem.com]
- [2. Synthesis of amide derivatives for electron deficient amines and functionalized carboxylic acids using EDC and DMAP and a catalytic amount of HOBT as the coupling reagents - PMC](#) [pmc.ncbi.nlm.nih.gov]
- [3. bachem.com](https://bachem.com) [bachem.com]
- [4. peptide.com](https://peptide.com) [peptide.com]
- [5. researchgate.net](https://researchgate.net) [researchgate.net]
- [6. people.uniurb.it](https://people.uniurb.it) [people.uniurb.it]
- [7. rsc.org](https://rsc.org) [rsc.org]
- [8. Thieme E-Books & E-Journals](https://thieme-connect.de) [thieme-connect.de]
- [9. merckmillipore.com](https://merckmillipore.com) [merckmillipore.com]
- [10. d-nb.info](https://d-nb.info) [d-nb.info]
- [11. Powerful and Easy Peptide Coupling Reagent | TCI AMERICA](https://tcichemicals.com) [tcichemicals.com]
- To cite this document: BenchChem. [comparison of different activating agents for Boc-Trp coupling]. BenchChem, [2026]. [Online PDF]. Available at: [\[https://www.benchchem.com/product/b13968289/docs#comparison-of-different-activating-agents-for-boc-trp-coupling\]](https://www.benchchem.com/product/b13968289/docs#comparison-of-different-activating-agents-for-boc-trp-coupling)

Disclaimer & Data Validity:

The information provided in this document is for Research Use Only (RUO) and is strictly not intended for diagnostic or therapeutic procedures. While BenchChem strives to provide accurate protocols, we make no warranties, express or implied, regarding the fitness of this product for every specific experimental setup.

Technical Support: The protocols provided are for reference purposes. Unsure if this reagent suits your experiment?

Need Industrial/Bulk Grade? [Request Custom Synthesis Quote](#)

BenchChem

Our mission is to be the trusted global source of essential and advanced chemicals, empowering scientists and researchers to drive progress in science and industry.

Contact

Address: 3281 E Guasti Rd
Ontario, CA 91761, United States
Phone: (601) 213-4426
Email: info@benchchem.com

[Contact our Ph.D. Support Team for a compatibility check](#)