

Theoretical structural analysis of substituted anilines

Author: BenchChem Technical Support Team. **Date:** May 2026

Compound of Interest

Compound Name: *3-Fluoro-4-(propan-2-yl)aniline*

CAS No.: 1369809-48-2

Cat. No.: B1396870

[Get Quote](#)

An In-Depth Technical Guide to the Theoretical Structural Analysis of Substituted Anilines

For Researchers, Scientists, and Drug Development Professionals

Abstract

Substituted anilines represent a cornerstone class of compounds in medicinal chemistry, materials science, and synthetic chemistry. Their chemical and physical properties—ranging from basicity and nucleophilicity to biological activity—are exquisitely sensitive to the nature and position of substituents on the aromatic ring. A thorough understanding of their structural and electronic characteristics is therefore paramount for rational molecular design and property prediction. This guide provides a comprehensive exploration of the theoretical and experimental methodologies employed to analyze substituted anilines. We will delve into the interplay between substituent effects, molecular geometry, electronic structure, and spectroscopic signatures. By integrating high-level computational chemistry with definitive experimental techniques, this document aims to equip researchers with the foundational knowledge and practical insights required to master the structural analysis of this vital chemical family.

Chapter 1: The Electronic Heart of the Matter: Basicity and Reactivity

The chemical behavior of aniline is dominated by the lone pair of electrons on the nitrogen atom. The availability of this lone pair for donation to a proton dictates the molecule's basicity, a fundamental property that governs its reactivity and physiological interactions. Substituents on the phenyl ring can dramatically alter the electron density on the nitrogen through a combination of inductive and resonance effects.

1.1. The Influence of Substituents on Basicity

- **Electron-Donating Groups (EDGs):** Groups such as methyl (-CH₃), methoxy (-OCH₃), and amino (-NH₂) increase the electron density on the aromatic ring and, by extension, the nitrogen atom.^{[1][2]} This enhanced electron density makes the lone pair more available for protonation, thereby increasing the basicity of the aniline derivative compared to unsubstituted aniline.^{[1][3]}
- **Electron-Withdrawing Groups (EWGs):** Conversely, groups like nitro (-NO₂), cyano (-CN), and halogens (-X) pull electron density away from the nitrogen atom.^[1] This delocalization reduces the availability of the nitrogen's lone pair, making the substituted aniline a weaker base.^{[2][3][4]} The pK_a of para-nitroaniline, for instance, drops to 1.0, a significant decrease from aniline's pK_a of 4.6.^[4]

The position of the substituent is also critical. Ortho and para substituents can participate directly in resonance with the amino group, exerting a stronger electronic influence than meta substituents, where the effect is primarily inductive.

1.2. Quantifying Electronic Effects: The Hammett Plot

Linear Free Energy Relationships (LFERs), most notably the Hammett equation, provide a powerful quantitative tool for correlating the electronic influence of substituents with reaction rates or equilibrium constants. The equation, $\log(K/K_0) = \sigma\rho$, relates the equilibrium constant (K) of a substituted species to that of the unsubstituted parent (K₀) through the substituent constant (σ) and the reaction constant (ρ).

For anilines, plotting the pKa values against the appropriate Hammett sigma constants (σ) typically yields a linear relationship.[5][6] The negative slope (ρ value) observed for aniline protonation indicates that the reaction is favored by electron-donating groups, which stabilize the resulting positive charge on the anilinium ion.[6][7] Deviations from linearity in a Hammett plot can often signify a change in reaction mechanism or complex steric interactions.[5]

Diagram: Influence of Substituents on Aniline Basicity

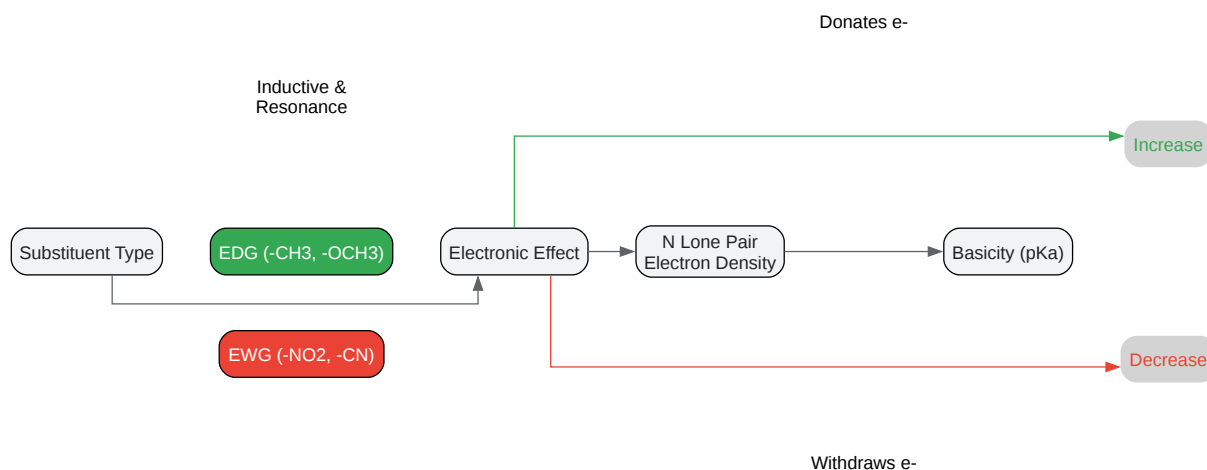

[Click to download full resolution via product page](#)

Caption: Logical flow from substituent type to its effect on basicity.

Table 1: pKa Values and Hammett Constants for para-Substituted Anilines

Substituent (p-X)	pKa of Anilinium Ion	Hammett Constant (σ)
-OCH ₃	5.34	-0.27
-CH ₃	5.08	-0.17
-H	4.60	0.00
-Cl	3.98	0.23
-Br	3.91	0.23
-CN	1.74	0.66
-NO ₂	1.00	0.78

Note: pKa values are from various sources and are approximate.[4]

Chapter 2: Deciphering the 3D Architecture: Molecular Geometry

While 2D structures are useful, the precise three-dimensional arrangement of atoms dictates how a molecule interacts with its environment. In substituted anilines, key geometric parameters include the C-N bond length and the pyramidalization of the amino group, often described by its out-of-plane angle. These parameters are highly sensitive to the electronic push-and-pull of ring substituents.[8]

2.1. Theoretical Prediction with Density Functional Theory (DFT)

DFT has emerged as a robust and widely used computational method for predicting the molecular and electronic structures of aniline derivatives.[9][10][11] By solving approximations of the Schrödinger equation, DFT can accurately calculate optimized geometries, vibrational frequencies, and electronic properties.[9][10]

Electron-withdrawing substituents, particularly at the para position, promote quinoid-like resonance structures. This increased double-bond character shortens the C-N bond and favors a more planar geometry for the amino group to maximize orbital overlap.[8] Conversely, electron-donating groups tend to increase the C-N bond length and the degree of pyramidalization at the nitrogen center.[8]

Protocol: Geometry Optimization using DFT

- Molecule Building: Construct the 3D structure of the desired substituted aniline using molecular modeling software (e.g., GaussView, Avogadro).
- Calculation Setup:
 - Select a DFT functional. The B3LYP hybrid functional is a common and reliable choice for organic molecules.[\[9\]](#)
 - Choose a basis set. The 6-31G** or 6-311++G** basis sets offer a good balance of accuracy and computational cost for these systems.[\[10\]](#)[\[11\]](#)
 - Specify the calculation type as "Optimization" (Opt) and "Frequency" (Freq) to find the minimum energy structure and confirm it is a true minimum (no imaginary frequencies).
 - Define the molecular charge (typically 0) and spin multiplicity (singlet for closed-shell molecules).
- Execution: Submit the calculation to a quantum chemistry package like Gaussian or Spartan. [\[9\]](#)
- Analysis:
 - Verify that the optimization converged and that the frequency calculation yielded zero imaginary frequencies.
 - Measure the key geometric parameters (bond lengths, bond angles, dihedral angles) from the optimized output structure.
 - Visualize the calculated vibrational modes and compare them to experimental IR or Raman spectra.

2.2. Experimental Validation with Single-Crystal X-ray Diffraction (SCXRD)

SCXRD is the definitive experimental technique for determining the precise three-dimensional atomic arrangement of a molecule in the solid state.[\[12\]](#) It provides unparalleled accuracy for

bond lengths, angles, and intermolecular interactions, serving as the ultimate benchmark for validating theoretical calculations.[\[12\]](#)[\[13\]](#)

Diagram: SCXRD Experimental Workflow

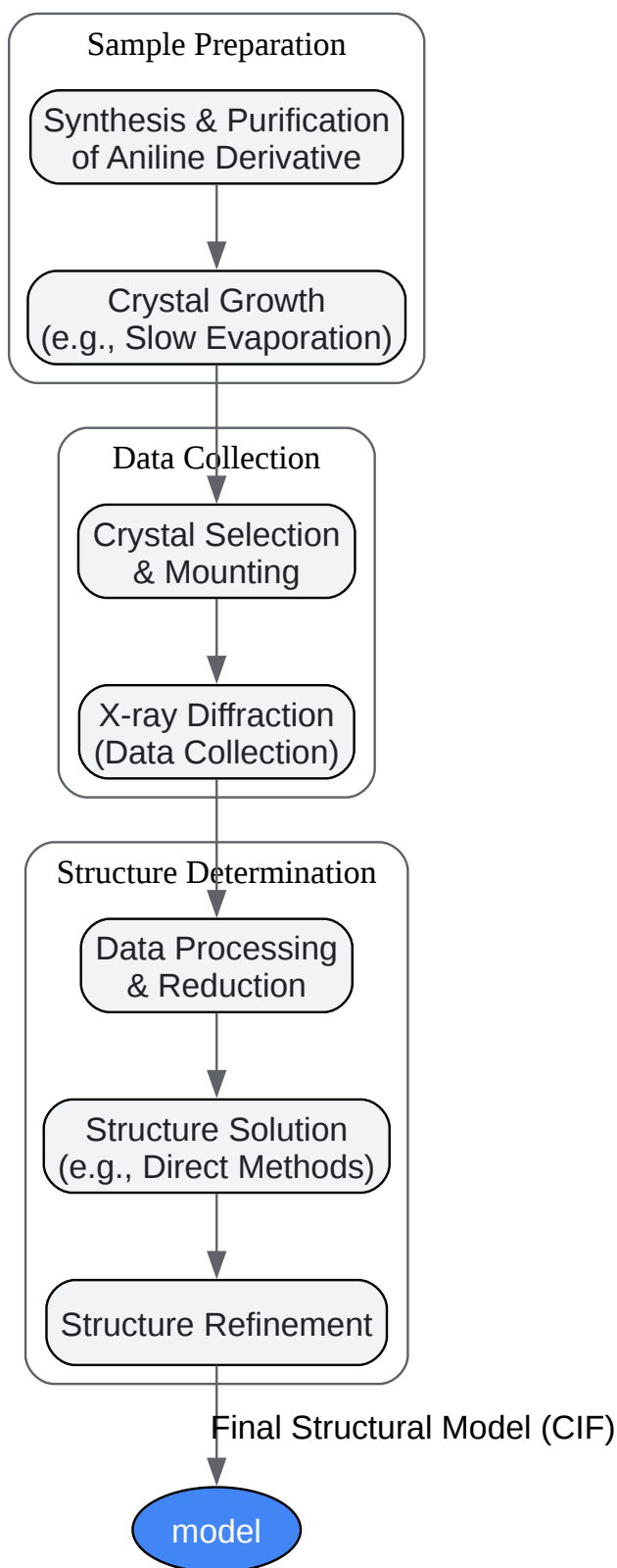

[Click to download full resolution via product page](#)

Caption: The workflow from a synthesized compound to a refined crystal structure.

Protocol: Single-Crystal X-ray Diffraction of an Aniline Derivative

- **Crystal Growth:** Obtaining high-quality single crystals is the most critical and often challenging step.^[12] Slow evaporation from a saturated solution is a common method.
 - **Solvent Selection:** Choose a solvent (e.g., toluene, methanol, acetone) where the compound has moderate solubility.^[12]
 - **Procedure:** Dissolve the purified aniline derivative in the chosen solvent, gently heating if necessary. Allow the solvent to evaporate slowly and undisturbed over several days.
- **Crystal Mounting:** Select a suitable, defect-free crystal under a microscope and mount it on a goniometer head.
- **Data Collection:**
 - Mount the crystal on the diffractometer. The crystal is typically flash-cooled to ~100 K to minimize thermal motion and radiation damage.^[12]
 - An X-ray source (e.g., Mo K α or Cu K α radiation) is used to irradiate the crystal.^[12]
 - The instrument rotates the crystal while a detector records the diffraction pattern (intensities and positions of thousands of reflections).
- **Structure Solution and Refinement:**
 - Specialized software is used to determine the unit cell parameters and space group from the diffraction pattern.
 - The initial positions of the atoms are determined using methods like direct methods or Patterson functions.
 - The atomic positions and thermal parameters are refined using a least-squares algorithm to achieve the best fit between the calculated and observed diffraction data. The final model is evaluated by metrics such as the R-factor.

Chapter 3: Probing Structure with Spectroscopy

Spectroscopic techniques provide a powerful, non-destructive window into the molecular structure and bonding of substituted anilines. Infrared (IR) and Nuclear Magnetic Resonance (NMR) spectroscopy are particularly valuable for probing the amino group and its local environment.

3.1. Infrared (IR) Spectroscopy and Hydrogen Bonding

The N-H stretching vibrations of the amino group in anilines typically appear in the 3300-3500 cm^{-1} region of the IR spectrum. The precise frequencies of the symmetric and asymmetric stretching bands are sensitive to both electronic substituent effects and hydrogen bonding.[14]

- **Intramolecular Hydrogen Bonding:** Substituents at the ortho position capable of accepting a hydrogen bond (e.g., $-\text{NO}_2$, $-\text{CHO}$, halogens) can form an internal $\text{N-H}\cdots\text{X}$ bond.[15] This interaction can be detected in the IR spectrum and is often used as evidence for specific conformations.[15][16]
- **Intermolecular Hydrogen Bonding:** In solution or the solid state, aniline derivatives can form intermolecular hydrogen bonds, leading to changes in the N-H stretching frequencies, which are often influenced by solvent polarity.[14]

3.2. Nuclear Magnetic Resonance (NMR) Spectroscopy

^1H NMR spectroscopy provides detailed information about the chemical environment of protons. The chemical shift (δ) of the $-\text{NH}_2$ protons is particularly informative.

- **Substituent Effects:** The electron density at the nitrogen atom directly influences the shielding of the attached protons. Electron-donating groups increase shielding, causing an upfield shift (lower δ), while electron-withdrawing groups decrease shielding, resulting in a downfield shift (higher δ).[17]
- **Hydrogen Bonding:** The formation of a hydrogen bond deshields the proton, causing a significant downfield shift. The chemical shift of the NH_2 protons is often concentration and solvent-dependent due to varying degrees of intermolecular hydrogen bonding.

Chapter 4: Application in Drug Discovery: Frontier Orbitals and QSAR

In drug development, it is crucial to relate a molecule's structure to its biological activity. Theoretical analysis of substituted anilines plays a vital role in this process through Frontier Molecular Orbital (FMO) theory and Quantitative Structure-Activity Relationship (QSAR) modeling.

4.1. Frontier Molecular Orbital (FMO) Theory

FMO theory focuses on the Highest Occupied Molecular Orbital (HOMO) and the Lowest Unoccupied Molecular Orbital (LUMO).^{[18][19]} These orbitals are critical for chemical reactivity.^[18]

- HOMO: The energy of the HOMO relates to the molecule's ability to donate electrons (its nucleophilicity or ease of oxidation). For anilines, the HOMO is typically centered on the aromatic ring and the nitrogen lone pair. EDGs raise the HOMO energy, making the molecule a better electron donor.
- LUMO: The energy of the LUMO relates to the molecule's ability to accept electrons (its electrophilicity or ease of reduction). EWGs lower the LUMO energy, making the molecule a better electron acceptor.
- HOMO-LUMO Gap: The energy difference between the HOMO and LUMO is a measure of chemical reactivity and stability.^[19] A smaller gap generally implies higher reactivity.^[19] DFT calculations are routinely used to compute these orbital energies.^{[20][21]}

4.2. Quantitative Structure-Activity Relationship (QSAR)

QSAR is a computational modeling approach that aims to find a statistical relationship between the chemical structures of a series of compounds and their biological activity.^{[22][23]} For substituted anilines, QSAR models are used to predict properties like toxicity or binding affinity to a biological target.^{[22][23][24][25]}

The process involves calculating a set of molecular descriptors for each aniline derivative. These descriptors can be:

- Electronic: Hammett constants, partial atomic charges, HOMO/LUMO energies.^{[22][23]}
- Steric: Molecular volume, surface area.

- Hydrophobic: The partition coefficient ($\log P$).

These descriptors are then used as independent variables in a regression analysis to build a mathematical model that can predict the activity of new, unsynthesized aniline derivatives.

Diagram: Conceptual QSAR Workflow

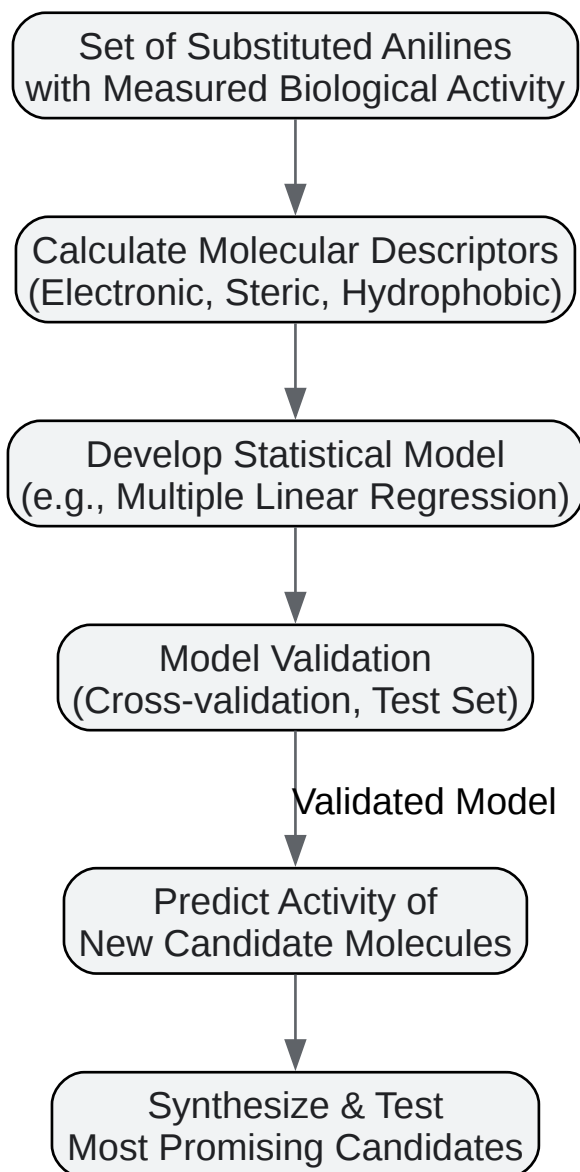

[Click to download full resolution via product page](#)

Need Custom Synthesis?

BenchChem offers custom synthesis for rare earth carbides and specific isotopic labeling.

Email: info@benchchem.com or [Request Quote Online](#).

Sources

- [1. scribd.com \[scribd.com\]](https://www.scribd.com)
- [2. Reactions of Aniline - Chemistry Steps \[chemistrysteps.com\]](https://www.chemistrysteps.com)
- [3. quora.com \[quora.com\]](https://www.quora.com)
- [4. m.youtube.com \[m.youtube.com\]](https://www.youtube.com)
- [5. asianpubs.org \[asianpubs.org\]](https://asianpubs.org)
- [6. researchgate.net \[researchgate.net\]](https://www.researchgate.net)
- [7. Enantioselective Hydroformylation of Aniline Derivatives - PMC \[pmc.ncbi.nlm.nih.gov\]](https://pubmed.ncbi.nlm.nih.gov)
- [8. afit.edu \[ait.edu\]](https://www.ait.edu)
- [9. catalog.article4pub.com \[catalog.article4pub.com\]](https://catalog.article4pub.com)
- [10. researchgate.net \[researchgate.net\]](https://www.researchgate.net)
- [11. Ferrate\(VI\) Oxidation Mechanism of Substituted Anilines: A Density Functional Theory Investigation - PMC \[pmc.ncbi.nlm.nih.gov\]](https://pubmed.ncbi.nlm.nih.gov)
- [12. pdf.benchchem.com \[pdf.benchchem.com\]](https://pdf.benchchem.com)
- [13. journals.iucr.org \[journals.iucr.org\]](https://journals.iucr.org)
- [14. Studies on the hydrogen bonding of aniline's derivatives by FT-IR - PubMed \[pubmed.ncbi.nlm.nih.gov\]](https://pubmed.ncbi.nlm.nih.gov)
- [15. researchgate.net \[researchgate.net\]](https://www.researchgate.net)
- [16. cdnsiencepub.com \[cdnsiencepub.com\]](https://cdnsiencepub.com)
- [17. escholarship.org \[escholarship.org\]](https://escholarship.org)
- [18. ossila.com \[ossila.com\]](https://ossila.com)
- [19. uomosul.edu.iq \[uomosul.edu.iq\]](https://uomosul.edu.iq)
- [20. researchgate.net \[researchgate.net\]](https://www.researchgate.net)
- [21. thaiscience.info \[thaiscience.info\]](https://thaiscience.info)

- [22. fileserver-az.core.ac.uk \[fileserver-az.core.ac.uk\]](#)
- [23. Substituted aniline interaction with submitochondrial particles and quantitative structure-activity relationships - PubMed \[pubmed.ncbi.nlm.nih.gov\]](#)
- [24. Synthesis, Antimicrobial and QSAR Studies of Substituted Anilides \[ijser.in\]](#)
- [25. The predicted models of anti-colon cancer and anti-hepatoma activities of substituted 4-anilino coumarin derivatives using quantitative structure-activity relationship \(QSAR\) - Journal of King Saud University - Science \[jksus.org\]](#)
- To cite this document: BenchChem. [Theoretical structural analysis of substituted anilines]. BenchChem, [2026]. [Online PDF]. Available at: [\[https://www.benchchem.com/product/b1396870/docs#theoretical-structural-analysis-of-substituted-anilines\]](https://www.benchchem.com/product/b1396870/docs#theoretical-structural-analysis-of-substituted-anilines)

Disclaimer & Data Validity:

The information provided in this document is for Research Use Only (RUO) and is strictly not intended for diagnostic or therapeutic procedures. While BenchChem strives to provide accurate protocols, we make no warranties, express or implied, regarding the fitness of this product for every specific experimental setup.

Technical Support: The protocols provided are for reference purposes. Unsure if this reagent suits your experiment?

Need Industrial/Bulk Grade? [Request Custom Synthesis Quote](#)

BenchChem

Our mission is to be the trusted global source of essential and advanced chemicals, empowering scientists and researchers to drive progress in science and industry.

Contact

Address: 3281 E Guasti Rd
Ontario, CA 91761, United States
Phone: (601) 213-4426
Email: info@benchchem.com

Contact our Ph.D. Support Team for a compatibility check