

Technical Support Center: Improving Regioselectivity in Chlorination Reactions

Author: BenchChem Technical Support Team. **Date:** May 2026

Compound of Interest

Compound Name: *1-Allyl-2-(chloromethyl)benzene*

CAS No.: 89121-39-1

Cat. No.: B13956829

[Get Quote](#)

A Guide for Researchers, Scientists, and Drug Development Professionals

Welcome to our technical support center. This guide is designed to provide you, as a senior application scientist, with in-depth, field-proven insights into controlling the regioselectivity of chlorination reactions, a critical aspect of synthetic chemistry. Here, we will explore the underlying principles and practical strategies to selectively chlorinate either the side-chain (benzylic position) or the aromatic ring of a substituted aromatic compound.

Frequently Asked Questions (FAQs)

Q1: What are the primary factors that determine whether chlorination occurs on the side-chain or the aromatic ring?

A1: The regioselectivity of chlorination is fundamentally dictated by the reaction mechanism, which is controlled by the reaction conditions. Side-chain chlorination, specifically at the benzylic position, proceeds through a free-radical mechanism.^{[1][2]} This pathway is favored by conditions that promote the formation of chlorine radicals, such as the presence of UV light or a radical initiator like AIBN (azobisisobutyronitrile).^{[3][4]} Conversely, chlorination of the aromatic

ring occurs via an electrophilic aromatic substitution (EAS) mechanism.[5][6] This pathway is promoted by the use of a Lewis acid catalyst, such as FeCl_3 or AlCl_3 , which increases the electrophilicity of the chlorine.[5][6][7]

Q2: Why is the benzylic position particularly susceptible to free-radical chlorination?

A2: The benzylic C-H bonds are weaker than typical sp^3 hybridized C-H bonds.[8] This is due to the resonance stabilization of the resulting benzylic radical intermediate.[8][9] The unpaired electron in the benzylic radical can be delocalized into the adjacent aromatic ring, significantly increasing its stability and lowering the activation energy for its formation.

Q3: Can I use N-Chlorosuccinimide (NCS) for both side-chain and aromatic ring chlorination?

A3: Yes, NCS is a versatile reagent that can participate in both radical and electrophilic chlorination pathways, depending on the reaction conditions.[9] For selective benzylic chlorination, NCS is typically used in the presence of a radical initiator or light in a non-polar solvent.[9] For electrophilic aromatic chlorination, NCS can be activated by a strong acid.

Q4: What is the role of a Lewis acid in aromatic chlorination?

A4: A Lewis acid, such as FeCl_3 or AlCl_3 , acts as a catalyst to activate the chlorine molecule.[5][6] It accepts a lone pair of electrons from one of the chlorine atoms, creating a highly polarized complex that is a much stronger electrophile.[6][10] This "activated" electrophile is then readily attacked by the electron-rich aromatic ring.[5]

Troubleshooting Guide: Common Issues and Solutions

Problem 1: Low selectivity for side-chain chlorination; significant formation of ring-chlorinated byproducts.

Potential Causes:

- Presence of Lewis Acid Impurities: Trace amounts of Lewis acidic impurities can catalyze the competing electrophilic aromatic substitution reaction.

- **Incorrect Reaction Conditions:** The conditions may not be optimal for promoting the free-radical pathway.
- **Highly Activated Aromatic Ring:** If the aromatic ring is highly activated with electron-donating groups, it can be more susceptible to electrophilic attack, even under radical conditions.

Solutions:

- **Ensure Rigorous Exclusion of Lewis Acids:**
 - Use freshly distilled solvents and reagents to remove any acidic impurities.
 - Glassware should be thoroughly cleaned and dried to avoid any residual Lewis acidic contaminants.
- **Optimize Radical Reaction Conditions:**
 - **Initiation:** Ensure a reliable source of radical initiation. For photochemical reactions, use a UV lamp with the appropriate wavelength.[4] For thermal initiation, use a suitable radical initiator like AIBN or benzoyl peroxide.[3]
 - **Solvent:** Employ non-polar solvents like carbon tetrachloride (with appropriate safety precautions) or cyclohexane, which are known to favor radical reactions.[11]
 - **Temperature:** Higher temperatures generally favor the radical pathway.[1]
- **Choice of Chlorinating Agent:**
 - Consider using N-chlorosuccinimide (NCS) or sulfuryl chloride (SO₂Cl₂) as alternatives to chlorine gas.[3][9] These reagents can offer higher selectivity for benzylic chlorination under radical conditions.[9][12]

Problem 2: Low yield of desired monochlorinated side-chain product and formation of di- and tri-chlorinated byproducts.

Potential Causes:

- **Excessive Chlorinating Agent:** Using a stoichiometric excess of the chlorinating agent will favor multiple chlorinations.
- **Prolonged Reaction Time:** Allowing the reaction to proceed for too long can lead to further substitution on the already chlorinated side-chain.
- **High Reaction Temperature:** While higher temperatures favor radical formation, excessively high temperatures can increase the rate of subsequent chlorinations.

Solutions:

- **Control Stoichiometry:**
 - Use a stoichiometric amount or a slight excess of the chlorinating agent relative to the starting material.
 - Consider slow, controlled addition of the chlorinating agent to maintain a low concentration throughout the reaction.
- **Monitor Reaction Progress:**
 - Utilize techniques like Gas Chromatography (GC) or Thin Layer Chromatography (TLC) to monitor the consumption of the starting material and the formation of the desired product.
 - Quench the reaction once the optimal conversion to the monochlorinated product is achieved.
- **Optimize Temperature:**
 - While initiation is necessary, avoid excessively high temperatures that can lead to uncontrollable reactions and decreased selectivity.^[4]

Problem 3: Poor regioselectivity in aromatic ring chlorination, with a mixture of ortho, meta, and para isomers.

Potential Causes:

- **Incorrect Catalyst or Catalyst Loading:** The choice and amount of Lewis acid catalyst can influence the regioselectivity.
- **Reaction Temperature:** Temperature can affect the isomer distribution.
- **Steric Hindrance:** Bulky substituents on the aromatic ring can sterically hinder attack at the ortho position.

Solutions:

- **Catalyst Selection and Optimization:**
 - For many substituted benzenes, FeCl_3 or AlCl_3 are effective catalysts.[\[6\]](#)
 - In some cases, milder Lewis acids or specific ionic liquids can offer improved regioselectivity.[\[13\]](#)[\[14\]](#)
 - The catalyst loading should be optimized; typically, a catalytic amount is sufficient.
- **Temperature Control:**
 - Lower reaction temperatures generally favor the formation of the para isomer due to steric factors.[\[1\]](#)
- **Consider Directing Group Effects:**
 - The inherent electronic properties of the substituent on the aromatic ring will be the primary determinant of the ortho/para vs. meta selectivity. Activating groups are ortho, para-directing, while deactivating groups (except halogens) are meta-directing.

Experimental Protocols

Protocol 1: Selective Side-Chain (Benzylic) Chlorination of Toluene

Objective: To selectively synthesize benzyl chloride from toluene.

Materials:

- Toluene
- Sulfuryl chloride (SO_2Cl_2)
- Azobisisobutyronitrile (AIBN)
- Anhydrous benzene or carbon tetrachloride (solvent)

Procedure:

- In a round-bottom flask equipped with a reflux condenser and a magnetic stirrer, dissolve toluene (1 equivalent) in anhydrous benzene or carbon tetrachloride.
- Add a catalytic amount of AIBN (e.g., 0.02 equivalents).
- Heat the mixture to reflux (approximately 80°C for benzene).
- Slowly add sulfuryl chloride (1 equivalent) dropwise to the refluxing solution.
- Continue refluxing and monitor the reaction progress by GC.
- Once the desired conversion is reached, cool the reaction mixture to room temperature.
- Carefully quench the reaction by slowly adding water.
- Separate the organic layer, wash with a saturated sodium bicarbonate solution, then with brine.
- Dry the organic layer over anhydrous magnesium sulfate, filter, and concentrate under reduced pressure.
- Purify the crude product by fractional distillation.

Protocol 2: Selective Aromatic Ring Chlorination of Toluene

Objective: To selectively synthesize a mixture of o-chlorotoluene and p-chlorotoluene.

Materials:

- Toluene
- Chlorine gas (Cl₂)
- Anhydrous iron(III) chloride (FeCl₃)
- Anhydrous dichloromethane (solvent)

Procedure:

- In a three-necked round-bottom flask equipped with a gas inlet tube, a mechanical stirrer, and a gas outlet connected to a trap, place anhydrous iron(III) chloride (catalytic amount).
- Add anhydrous dichloromethane and toluene (1 equivalent).
- Cool the mixture in an ice bath.
- Slowly bubble chlorine gas through the stirred solution.
- Monitor the reaction progress by GC.
- Once the desired conversion is achieved, stop the chlorine flow and purge the system with nitrogen.
- Quench the reaction by carefully adding water.
- Separate the organic layer, wash with a dilute sodium thiosulfate solution to remove excess chlorine, then with water, and finally with brine.
- Dry the organic layer over anhydrous calcium chloride, filter, and remove the solvent by distillation.
- The resulting mixture of chlorotoluene isomers can be separated by fractional distillation.

Data Presentation

Table 1: Comparison of Reaction Conditions for Selective Chlorination of Toluene

Feature	Side-Chain (Benzylic) Chlorination	Aromatic Ring Chlorination
Reaction Type	Free Radical Substitution	Electrophilic Aromatic Substitution
Primary Product(s)	Benzyl chloride	o-Chlorotoluene, p-Chlorotoluene
Typical Reagents	Cl ₂ , SO ₂ Cl ₂ , NCS	Cl ₂
Catalyst/Initiator	UV light, AIBN, Benzoyl Peroxide	FeCl ₃ , AlCl ₃
Solvent	Non-polar (e.g., CCl ₄ , Benzene)	Non-polar (e.g., CH ₂ Cl ₂ , CS ₂)
Temperature	Elevated (reflux)	Low (e.g., 0°C)

Visualizations

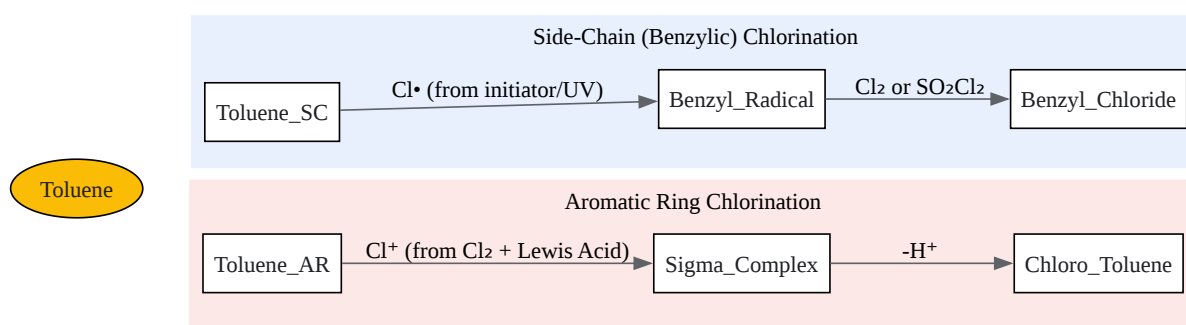

[Click to download full resolution via product page](#)

Caption: Competing pathways for the chlorination of toluene.

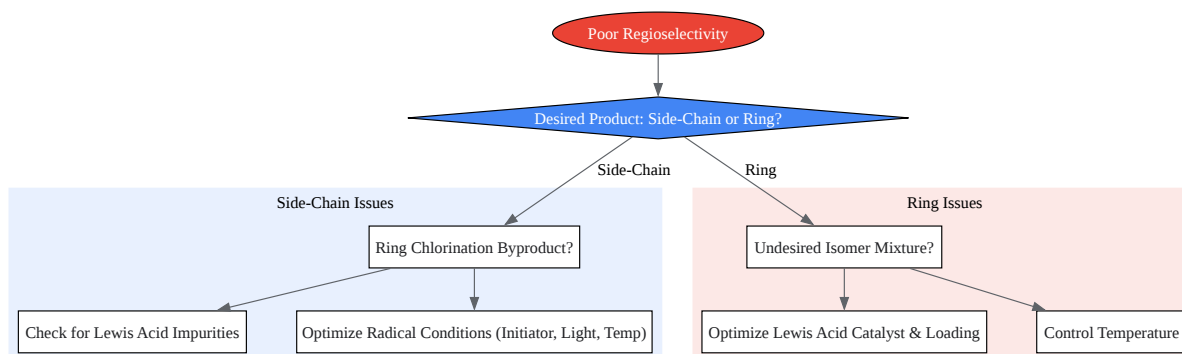

[Click to download full resolution via product page](#)

Caption: Troubleshooting decision tree for poor regioselectivity.

References

- Electrophilic Aromatic Substitutions: Chlorination and Bromination - Master Organic Chemistry. [\[Link\]](#)
- Video: Electrophilic Aromatic Substitution: Chlorination and Bromination of Benzene - JoVE. [\[Link\]](#)
- Highly selective chlorination of toluene to benzyl chloride - ProQuest. [\[Link\]](#)
- Selective Photochemical Continuous Flow Benzylic Monochlorination | Organic Process Research & Development - ACS Publications. [\[Link\]](#)
- Catalyst-Tuned Electrophilic Chlorination of Diverse Aromatic Compounds with Sulfuryl Chloride and Regioselective Chlorination of Phenols with Organocatalysts | Request PDF -

ResearchGate. [\[Link\]](#)

- Benzylic chlorination by sulphuryl chloride: suppression of chlorine atom chains - Journal of the Chemical Society D - RSC Publishing. [\[Link\]](#)
- Direct Benzylic Polychlorination of (Poly)Azines with N-Chlorosuccinimide - Organic Chemistry Frontiers (RSC Publishing) DOI:10.1039/D3QO00611E. [\[Link\]](#)
- Selective Photochemical Continuous Flow Benzylic Monochlorination - Vapourtec. [\[Link\]](#)
- Electrophilic Aromatic Substitution - Chlorination - YouTube. [\[Link\]](#)
- Selectivity In Free Radical Reactions - Master Organic Chemistry. [\[Link\]](#)
- Electrophilic Aromatic Substitution – The Mechanism - Chemistry Steps. [\[Link\]](#)
- Catalyst-Tuned Electrophilic Chlorination of Diverse Aromatic Compounds with Sulfuryl Chloride and Regioselective Chlorination of Phenols with Organocatalysts - PubMed. [\[Link\]](#)
- Photochlorination of toluene – the thin line between intensification and selectivity. Part 1. [\[Link\]](#)
- Cu-Catalyzed Site-Selective Benzylic Chlorination Enabling Net C H Coupling with Oxidatively Sensitive Nucleophiles - PMC. [\[Link\]](#)
- N-Chlorosuccinimide (NCS) - Organic Chemistry Portal. [\[Link\]](#)
- Chlorination of Toluene to o-Chlorotoluene Catalyzed by Ionic Liquids - MDPI. [\[Link\]](#)
- Visible Light-Catalyzed Benzylic C–H Bond Chlorination by a Combination of Organic Dye (Acr⁺-Mes) and N-Chlorosuccinimide - ACS Publications. [\[Link\]](#)
- Catalyst-Tuned Electrophilic Chlorination of Diverse Aromatic Compounds with Sulfuryl Chloride and Regioselective Chlorination of Phenols with Organocatalysts | The Journal of Organic Chemistry - ACS Publications. [\[Link\]](#)
- Selective Chlorination of Toluene to p-Chlorotoluene Catalyzed by Nanosized Zeolite K-L Catalysts | Request PDF - ResearchGate. [\[Link\]](#)

- 154 CHM2211 Reactions at Benzylic Position Free Radical Halogenation - YouTube. [[Link](#)]
- Chlorination by Sulfuryl Chloride. V.1) Reaction with Benzyl Alcohols By Mannosuke ARAI (Received July 18, 1964). [[Link](#)]
- aromatic chlorination bromination electrophilic substitution in benzene methylbenzene mechanism reagents reaction conditions organic synthesis - Doc Brown's Chemistry. [[Link](#)]
- Visible Light-Catalyzed Benzylic C–H Bond Chlorination by a Combination of Organic Dye (Acr+-Mes) and N-Chlorosuccinimide - ACS Publications. [[Link](#)]
- Water Treatment Process Troubleshooting Guide - Novi AMS. [[Link](#)]
- (PDF) N-Chlorosuccinimide (NCS) - ResearchGate. [[Link](#)]
- What happens when toluene reacts with sulfural chloride (SO₂Cl₂)? - Quora. [[Link](#)]
- CN1948245A - Method of producing chlorobenzyl by photochlorination - Google P
- Sulfuryl chloride - Wikipedia. [[Link](#)]
- Pool Chlorinator Troubleshooting - DIY Pool Resources - INYOPools.com. [[Link](#)]
- Structure and Mechanism: A free radical: is any molecular species capable of independent existence that. [[Link](#)]
- Selectivity in Free Radical Reactions: Bromination vs. Chlorination. [[Link](#)]
- No Chlorine Reading - Troubleshooting Guide. [[Link](#)]
- 10.1 Free Radical Halogenation | Organic Chemistry - YouTube. [[Link](#)]
- Why can toluene be chlorinated at either the benzylic position or the ring depending on the conditions? - Chemistry Stack Exchange. [[Link](#)]
- Ch17 Reactions of Aromatic Compounds. [[Link](#)]
- free radical substitution in the methylbenzene and chlorine reaction - Chemguide. [[Link](#)]

- [Specific Solvent Issues with Chlorination - Wordpress. \[Link\]](#)
- [How to Cure CHLORINE LOCK and CHLORINE DEMAND - YouTube. \[Link\]](#)
- [Recent Advances in Direct Regioselective C-H Chlorination at Aromatic and Aliphatic - PubMed. \[Link\]](#)
- [Substitution Reactions of Benzene and Other Aromatic Compounds - MSU chemistry. \[Link\]](#)
- [Revision Notes - Predicting Halogenation: Side-Chain vs. Aromatic Ring | Hydrocarbons \(Arenes\) | Chemistry - 9701 | AS & A Level | Sparkl. \[Link\]](#)
- [11.10: Benzylic Bromination of Aromatic Compounds - Chemistry LibreTexts. \[Link\]](#)
- [Organic Chemistry Benzylic And Aromatic Reactions Of Substituted Benzene. Free In-Depth Study Guide. \[Link\]](#)
- [US5840998A - Side chain chlorination of aromatic and heterocyclic ethers - Google P](#)
- [Regiospecific chlorination of aromatic substrates using donor–acceptor and hydrogen bonding interactions - RSC Publishing. \[Link\]](#)
- [Recent Advances in Direct Regioselective C–H Chlorination at Aromatic and Aliphatic. \[Link\]](#)

Need Custom Synthesis?

BenchChem offers custom synthesis for rare earth carbides and specific isotopic labeling.

Email: info@benchchem.com or [Request Quote Online](#).

Sources

- [1. chemistry.stackexchange.com \[chemistry.stackexchange.com\]](https://chemistry.stackexchange.com)
- [2. chemguide.co.uk \[chemguide.co.uk\]](https://chemguide.co.uk)
- [3. connectsci.au \[connectsci.au\]](https://connectsci.au)
- [4. pubs.acs.org \[pubs.acs.org\]](https://pubs.acs.org)
- [5. masterorganicchemistry.com \[masterorganicchemistry.com\]](https://masterorganicchemistry.com)

- [6. Video: Electrophilic Aromatic Substitution: Chlorination and Bromination of Benzene \[jove.com\]](#)
- [7. aromatic chlorination bromination electrophilic substitution in benzene methylbenzene mechanism reagents reaction conditions organic synthesis \[docbrown.info\]](#)
- [8. chem.libretexts.org \[chem.libretexts.org\]](#)
- [9. benchchem.com \[benchchem.com\]](#)
- [10. m.youtube.com \[m.youtube.com\]](#)
- [11. Specific Solvent Issues with Chlorination - Wordpress \[reagents.acsgcipr.org\]](#)
- [12. masterorganicchemistry.com \[masterorganicchemistry.com\]](#)
- [13. Chlorination of Toluene to o-Chlorotoluene Catalyzed by Ionic Liquids \[mdpi.com\]](#)
- [14. researchgate.net \[researchgate.net\]](#)
- To cite this document: BenchChem. [Technical Support Center: Improving Regioselectivity in Chlorination Reactions]. BenchChem, [2026]. [Online PDF]. Available at: [\[https://www.benchchem.com/product/b13956829/docs#technical-support-center-improving-regioselectivity-in-chlorination-reactions\]](https://www.benchchem.com/product/b13956829/docs#technical-support-center-improving-regioselectivity-in-chlorination-reactions)

Disclaimer & Data Validity:

The information provided in this document is for Research Use Only (RUO) and is strictly not intended for diagnostic or therapeutic procedures. While BenchChem strives to provide accurate protocols, we make no warranties, express or implied, regarding the fitness of this product for every specific experimental setup.

Technical Support: The protocols provided are for reference purposes. Unsure if this reagent suits your experiment?

Need Industrial/Bulk Grade? [Request Custom Synthesis Quote](#)

BenchChem

Our mission is to be the trusted global source of essential and advanced chemicals, empowering scientists and researchers to drive progress in science and industry.

Contact

Address: 3281 E Guasti Rd

Ontario, CA 91761, United States

Phone: (601) 213-4426

Email: info@benchchem.com

[Contact our Ph.D. Support Team for a compatibility check](#)