

Structural Elucidation of N-(butan-2-yl)propanamide: A Multi-Modal Spectroscopic Guide

Author: BenchChem Technical Support Team. **Date:** April 2026

Compound of Interest

Compound Name: *N*-(butan-2-yl)propanamide

CAS No.: 5827-73-6

Cat. No.: B13952968

[Get Quote](#)

Executive Summary & Structural Context[1][2][3]

N-(butan-2-yl)propanamide (also known as N-sec-butylpropionamide) represents a critical structural motif in medicinal chemistry, serving as a model for peptide bond interactions within a sterically hindered, hydrophobic environment. Unlike its linear isomer (N-n-butylpropanamide), the branching at the

-carbon of the amine moiety introduces chirality and steric bulk that significantly influences its spectroscopic signature.

This guide provides a definitive reference for the identification of this molecule, synthesizing data from Nuclear Magnetic Resonance (NMR), Infrared Spectroscopy (IR), and Mass Spectrometry (MS). The protocols and assignments detailed here are designed to serve as a self-validating system for researchers synthesizing peptidomimetics or analyzing metabolic byproducts.

Molecular Specifications

- IUPAC Name: **N-(butan-2-yl)propanamide**^{[1][2]}

- Formula:

- Molecular Weight: 129.20 g/mol ^{[2][3][4]}

- Key Feature: Chiral center at

(sec-butyl group), typically analyzed as a racemate in achiral solvents.

Infrared Spectroscopy (FT-IR)

In the solid state or concentrated solution, secondary amides like **N-(butan-2-yl)propanamide** exhibit strong hydrogen bonding networks. The steric hindrance of the sec-butyl group slightly weakens these interactions compared to the n-butyl isomer, resulting in subtle frequency shifts.

Diagnostic Bands & Assignment

Frequency ()	Intensity	Vibrational Mode	Assignment Logic (Causality)
3280 – 3300	Med, Broad	(Stretch)	Amide A: Hydrogen-bonded N-H stretch. In dilute , this shifts to ~3440 (free N-H).
2960 – 2870	Strong		Aliphatic Backbone: Asymmetric/symmetric stretching of methyl and methylene groups.
1640 – 1650	Strong		Amide I: The most diagnostic band. Lower frequency than ketones due to resonance delocalization of the nitrogen lone pair into the carbonyl.
1540 – 1550	Strong		Amide II: A mixed mode characteristic of secondary amides (trans-configuration). Absent in lactams or tertiary amides.

Experimental Protocol: Thin Film (Neat)

- Preparation: Place 1 drop of neat liquid **N-(butan-2-yl)propanamide** between two NaCl or KBr salt plates.

- Compression: Gently rotate plates to create a capillary film (avoid overtightening to prevent fringing patterns).
- Acquisition: Scan from 4000 to 600

(32 scans, 4

resolution).
- Validation: Ensure the Amide I/II ratio is approximately 1:1 in intensity.

Mass Spectrometry (EI-MS)[3][8]

Electron Ionization (EI) at 70 eV induces fragmentation driven by the stability of the resulting carbocations and the radical release. For N-alkyl amides,

-cleavage and McLafferty rearrangements are the dominant mechanisms.

Fragmentation Pathway Analysis

The molecular ion (

) at m/z 129 is typically weak due to the facile fragmentation of the aliphatic chains.

m/z	Fragment Ion	Mechanism
129		Molecular Ion.
114		-Cleavage (Methyl loss): Loss of the terminal methyl from the sec-butyl group.
100		-Cleavage (Ethyl loss): Loss of the ethyl group from the sec-butyl chain (favored over methyl loss due to better stability of the leaving radical).
73		McLafferty Rearrangement: Migration of a -hydrogen from the sec-butyl chain to the carbonyl oxygen, followed by C-N bond cleavage. This is the Base Peak or a major diagnostic peak.
57		-Cleavage (Acyl): Formation of the propionyl cation.

Visualization: Fragmentation Logic

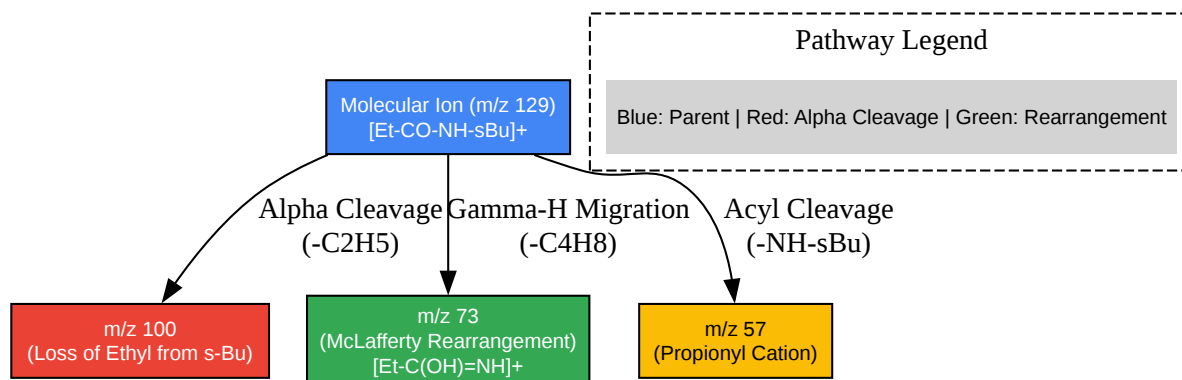

[Click to download full resolution via product page](#)

Figure 1: Primary fragmentation pathways for **N-(butan-2-yl)propanamide** under Electron Ionization (70 eV).

Nuclear Magnetic Resonance (NMR)[9]

NMR provides the most definitive structural proof. The presence of the chiral center at the butyl chain renders the protons on the adjacent methylene group (

) diastereotopic, meaning they are magnetically non-equivalent and may appear as complex multiplets rather than a simple quartet.

NMR Data (400 MHz,)

Chemical Shift Reference: TMS (

0.00) or

residual (

7.26).

Shift (ppm)	Multiplicity	Integration	Assignment	Coupling (Hz)
5.40 – 5.80	Broad Singlet	1H	NH	Exchangeable. Shift varies with conc/temp.
3.85 – 3.95	Multiplet	1H	(Methine)	Coupled to (Me) and ().
2.18	Quartet	2H	(Propionyl)	Hz. Coupled to .
1.40 – 1.55	Multiplet	2H	(Butyl)	Diastereotopic. Complex splitting (ABX system).
1.14	Triplet	3H	(Propionyl)	Hz.
1.10	Doublet	3H	(Butyl)	Hz. Overlaps with propionyl methyl.
0.91	Triplet	3H	(Butyl term.)	Hz.

NMR Data (100 MHz,)

Shift (ppm)	Type	Assignment	Notes
173.2	Cq	C=O	Carbonyl carbon.
46.5	CH	(Methine)	Alpha to Nitrogen.
30.1		(Propionyl)	Alpha to Carbonyl.
29.8		(Butyl)	Beta to Nitrogen.
20.5		(Butyl Me)	Branch methyl.
10.5		(Butyl term.)	Terminal methyl.
10.1		(Propionyl Me)	

Note: The assignments of the two methyl groups at ~10 ppm and the two methylene groups at ~30 ppm should be confirmed via HSQC/HMBC if absolute certainty is required, as they are chemically similar.

Visualization: Structure-Spectrum Correlation

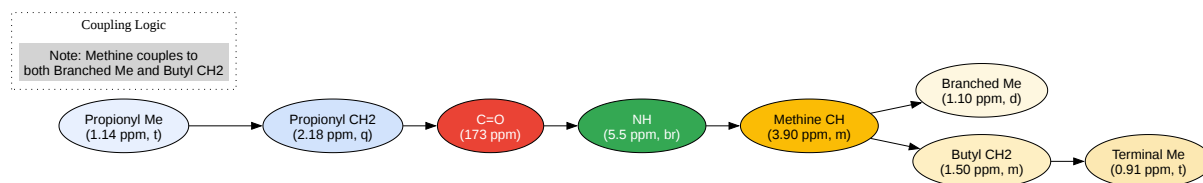

[Click to download full resolution via product page](#)

Figure 2: Connectivity and chemical shift logic for **N-(butan-2-yl)propanamide**.

Experimental Protocols for Validation

To ensure high-fidelity data that matches the values above, follow these specific sample preparation steps.

A. NMR Sample Preparation

- Solvent Selection: Use

(99.8% D) containing 0.03% TMS v/v.
- Concentration:
 - For

: Dissolve 5–10 mg of sample in 0.6 mL solvent.
 - For

: Dissolve 30–50 mg of sample in 0.6 mL solvent to ensure adequate signal-to-noise for the quaternary carbonyl carbon.
- Filtration: Filter through a glass wool plug into the NMR tube to remove suspended solids which cause line broadening.

B. GC-MS Method[5]

- Column: DB-5ms or equivalent (30m x 0.25mm ID).
- Carrier Gas: Helium at 1.0 mL/min constant flow.
- Temperature Program: Hold 60°C for 1 min; Ramp 20°C/min to 250°C; Hold 3 min.
- Inlet: Split mode (50:1), 250°C.
- Rationale: The split injection prevents detector saturation, and the non-polar column separates the amide from potential amine or acid precursors.

References

- Silverstein, R. M., Webster, F. X., & Kiemle, D. J. (2005). Spectrometric Identification of Organic Compounds. 7th Edition. John Wiley & Sons.[2] (Standard text for amide fragmentation and IR bands).
- National Institute of Standards and Technology (NIST). N-n-Butylpropionamide Mass Spectrum (Isomer Comparison). NIST Chemistry WebBook, SRD 69.[5] Available at: [Link]
- SDBS. Spectral Database for Organic Compounds. SDBS No. 6788 (Analogous Amide Data). National Institute of Advanced Industrial Science and Technology (AIST). Available at: [Link]
- Pretsch, E., Bühlmann, P., & Badertscher, M. (2009). Structure Determination of Organic Compounds: Tables of Spectral Data. Springer.[6] (Source for chemical shift prediction rules).

Need Custom Synthesis?

BenchChem offers custom synthesis for rare earth carbides and specific isotopic labeling.

Email: info@benchchem.com or [Request Quote Online](#).

Sources

- 1. N-butan-2-ylidenepropanamide | C7H13NO | CID 123514331 - PubChem [pubchem.ncbi.nlm.nih.gov]
- 2. N-(Butan-2-yl)propanamide | C7H15NO | CID 4548383 - PubChem [pubchem.ncbi.nlm.nih.gov]
- 3. N-Butylpropanamide | C7H15NO | CID 221431 - PubChem [pubchem.ncbi.nlm.nih.gov]
- 4. N-n-Butylpropionamide (CAS 2955-67-1) - Chemical & Physical Properties by Cheméo [chemeo.com]
- 5. N-n-Butylpropionamide [webbook.nist.gov]
- 6. N-Butylpentanamide | C9H19NO | CID 137707 - PubChem [pubchem.ncbi.nlm.nih.gov]
- To cite this document: BenchChem. [Structural Elucidation of N-(butan-2-yl)propanamide: A Multi-Modal Spectroscopic Guide]. BenchChem, [2026]. [Online PDF]. Available at:

[\[https://www.benchchem.com/product/b13952968/docs#structural-elucidation-of-n-butan-2-yl-propanamide-a-multi-modal-spectroscopic-guide\]](https://www.benchchem.com/product/b13952968/docs#structural-elucidation-of-n-butan-2-yl-propanamide-a-multi-modal-spectroscopic-guide)

Disclaimer & Data Validity:

The information provided in this document is for Research Use Only (RUO) and is strictly not intended for diagnostic or therapeutic procedures. While BenchChem strives to provide accurate protocols, we make no warranties, express or implied, regarding the fitness of this product for every specific experimental setup.

Technical Support: The protocols provided are for reference purposes. Unsure if this reagent suits your experiment?

Need Industrial/Bulk Grade? [Request Custom Synthesis Quote](#)

BenchChem

Our mission is to be the trusted global source of essential and advanced chemicals, empowering scientists and researchers to drive progress in science and industry.

Contact

Address: 3281 E Guasti Rd
Ontario, CA 91761, United States
Phone: (601) 213-4426
Email: info@benchchem.com

[Contact our Ph.D. Support Team for a compatibility check](#)