

Vilsmeier-Haack Reactions: A Technical Support Guide to Mastering Temperature Control

Author: BenchChem Technical Support Team. **Date:** May 2026

Compound of Interest

Compound Name: 6-Methoxybenzo[b]thiophene-2-carbaldehyde

CAS No.: 1001203-26-4

Cat. No.: B1395934

[Get Quote](#)

Welcome to the Technical Support Center for the Vilsmeier-Haack reaction. This guide is designed for researchers, scientists, and drug development professionals to provide in-depth troubleshooting advice and frequently asked questions (FAQs) for managing the critical parameter of temperature during this versatile formylation reaction. Precise temperature control is paramount for achieving high yields, ensuring regioselectivity, and, most importantly, guaranteeing the safety of the procedure.

The Crucial Role of Temperature in Vilsmeier-Haack Reactions

The Vilsmeier-Haack reaction is a powerful method for introducing a formyl group onto electron-rich aromatic and heteroaromatic compounds.^[1] The reaction proceeds in two main stages: the formation of the Vilsmeier reagent and the subsequent electrophilic attack on the substrate. Both stages are highly sensitive to temperature fluctuations.

The initial formation of the Vilsmeier reagent, a chloroiminium salt, from a substituted amide like N,N-dimethylformamide (DMF) and a halogenating agent such as phosphorus oxychloride

(POCl₃), is a significantly exothermic process.[2] Failure to dissipate this heat can lead to the thermal decomposition of the reagent, reducing its efficacy and posing a safety risk.[3][4]

The subsequent formylation step's temperature requirements are highly substrate-dependent. While some highly activated substrates react readily at low temperatures, less reactive compounds may necessitate heating to achieve a reasonable reaction rate.[3][5] However, excessive temperatures can promote unwanted side reactions, such as polymerization, charring, or the formation of undesired isomers.[3][6]

Troubleshooting Guide: Temperature-Related Issues

This section directly addresses common problems encountered during Vilsmeier-Haack reactions that are often rooted in improper temperature control.

Problem	Potential Cause(s)	Recommended Solution(s)
Low or No Product Yield	<p>1. Decomposition of Vilsmeier Reagent: The temperature during reagent formation was too high, leading to its degradation.[3] 2. Insufficient Reaction Temperature: The substrate is not reactive enough at the chosen temperature.[3][7] 3. Reaction Time Too Short: The reaction has not proceeded to completion at the given temperature.</p>	<p>1. Strictly control the temperature during the addition of POCl₃ to DMF, maintaining it between 0-5°C using an ice-water bath and slow, dropwise addition.[7] 2. After substrate addition at a low temperature, gradually increase the reaction temperature. Monitor the reaction's progress by TLC or LC-MS. For less reactive substrates, heating to 40-80°C or even higher may be necessary.[5][7] 3. Extend the reaction time and continue to monitor for product formation.</p>
Formation of a Precipitate/Stuck Stir Bar During Reagent Preparation	<p>1. High Concentration: The concentration of POCl₃ and DMF is too high, causing the Vilsmeier reagent salt to precipitate. 2. Inefficient Cooling: Localized heating during the exothermic reaction between POCl₃ and DMF can lead to solidification.</p>	<p>1. Add a co-solvent such as dichloromethane (DCM) or dichloroethane (DCE) before or during the addition of POCl₃ to keep the reagent in solution. [7] 2. Ensure vigorous stirring and slow, dropwise addition of POCl₃ to a well-chilled DMF solution to effectively dissipate heat. Using a larger flask can also aid in heat distribution.[7]</p>
Formation of Multiple Products/Isomers	<p>Suboptimal Reaction Temperature: The chosen temperature may be promoting the formation of multiple isomers or by-products like chlorinated species.[3][5]</p>	<p>1. Attempt the reaction at a lower temperature for a longer duration to favor the thermodynamically more stable product.[3] 2. Conversely, a higher temperature for a shorter time might favor a</p>

kinetically controlled product. Experiment with a range of temperatures to find the optimal condition for the desired isomer.[3]

Darkening or Charring of the Reaction Mixture

Excessive Heat: The reaction temperature is too high, leading to the decomposition of the starting material, product, or solvent.[3][6]

1. Immediately reduce the temperature. 2. Ensure efficient stirring and adequate cooling. 3. Consider a more gradual increase in temperature during the reaction. 4. For highly reactive substrates, conduct the entire reaction at a lower temperature (e.g., room temperature or below).[3]

Runaway Reaction

Poor Temperature Control: The exothermic formation of the Vilsmeier reagent or the reaction itself was not adequately controlled.[4][6]

1. Prevention is key: Always use a properly sized cooling bath and add reagents dropwise with careful monitoring of the internal temperature. 2. For larger-scale reactions, consider a "reverse addition" where the substrate solution is added to the pre-formed Vilsmeier reagent at a controlled rate. 3. Ensure the quenching process is also well-controlled by adding the reaction mixture slowly to a vigorously stirred vessel of crushed ice.[8]

Frequently Asked Questions (FAQs)

Q1: What is the ideal temperature range for a Vilsmeier-Haack reaction?

A1: There is no single ideal temperature range, as it is highly dependent on the substrate's reactivity. However, a general guideline is to prepare the Vilsmeier reagent at a low temperature, typically between 0°C and 10°C, to ensure its stability.[3] The subsequent reaction with the aromatic substrate can be conducted at temperatures ranging from 0°C up to 80-100°C, and in some cases, even higher for particularly unreactive substrates.[7][9]

Q2: How does temperature impact the Vilsmeier reagent itself?

A2: The Vilsmeier reagent is thermally unstable.[3][4] At elevated temperatures, it can decompose, which not only reduces the yield of the desired product but can also present significant safety hazards, including the potential for a runaway reaction.[3][4] Therefore, it is crucial to prepare the reagent at low temperatures and, in many protocols, to add it to the substrate solution while maintaining a controlled low temperature.

Q3: Can temperature influence the regioselectivity of the Vilsmeier-Haack reaction?

A3: Yes, temperature can influence the regioselectivity of the formylation. While the electronic and steric properties of the substrate are the primary determinants of where the formyl group is introduced, the reaction temperature can affect the product distribution. For some substrates, different isomers may be favored at different temperatures.[3]

Q4: What are common by-products observed at elevated temperatures?

A4: At higher temperatures, besides the decomposition of the Vilsmeier reagent, side reactions involving the substrate or product can occur. This may include polymerization, charring, or the formation of undesired isomers.[3][6] In some instances, the Vilsmeier reagent can act as a chlorinating agent, leading to chlorinated byproducts, especially at higher temperatures.[5]

Q5: Why is the quenching step so critical for temperature control?

A5: The quenching step, typically involving the addition of the reaction mixture to ice-cold water or a basic solution, is highly exothermic. This is due to the hydrolysis of any unreacted POCl_3 and the Vilsmeier reagent.[8] A slow and controlled quench into a vigorously stirred, well-cooled medium is essential to manage this exotherm and prevent a dangerous temperature spike or "volcano-like" eruption.[8][10]

Experimental Protocols

Protocol 1: General Procedure for Vilsmeier-Haack Formylation

This protocol provides a general guideline and may require optimization for specific substrates.

- Reagent Preparation (0-5°C):
 - In a flame-dried, three-necked round-bottom flask equipped with a magnetic stirrer, a dropping funnel, and a nitrogen inlet, place anhydrous N,N-dimethylformamide (DMF).
 - Cool the flask to 0°C in an ice-water bath.
 - Add phosphorus oxychloride (POCl₃) (typically 1.1 to 1.5 equivalents) dropwise to the stirred DMF solution via the dropping funnel over 30-60 minutes.
 - Crucially, maintain the internal temperature below 5°C throughout the addition.^[7]
 - After the addition is complete, allow the mixture to stir at 0°C for an additional 30 minutes to ensure complete formation of the Vilsmeier reagent.^[7]
- Reaction with Aromatic Substrate (Temperature is Substrate-Dependent):
 - Dissolve the electron-rich aromatic substrate (1.0 equivalent) in a minimal amount of anhydrous DMF or a suitable co-solvent like DCM.
 - Add the substrate solution dropwise to the pre-formed Vilsmeier reagent at 0°C.
 - After the addition, the reaction mixture can be stirred at 0°C, allowed to warm to room temperature, or heated (e.g., 40-80°C) depending on the substrate's reactivity.^[7]
 - Monitor the reaction's progress by TLC or LC-MS.
- Work-up and Quenching (Controlled Temperature):
 - Once the reaction is complete, cool the mixture back down in an ice bath.

- Prepare a separate beaker with a vigorously stirred mixture of crushed ice and a saturated aqueous solution of sodium acetate or sodium bicarbonate.
- Slowly and carefully pour the reaction mixture into the ice-cold aqueous solution. Monitor for any significant temperature increase.
- Stir the resulting mixture for 10-30 minutes to ensure complete hydrolysis of the intermediate iminium salt.[7]
- Extract the aqueous mixture with an appropriate organic solvent (e.g., ethyl acetate, diethyl ether, or DCM) multiple times.
- Combine the organic layers, wash with brine, dry over anhydrous sodium sulfate, filter, and concentrate under reduced pressure.
- Purify the crude product by column chromatography, recrystallization, or distillation.

Visualizing Workflows and Mechanisms

Vilsmeier-Haack Reaction Mechanism

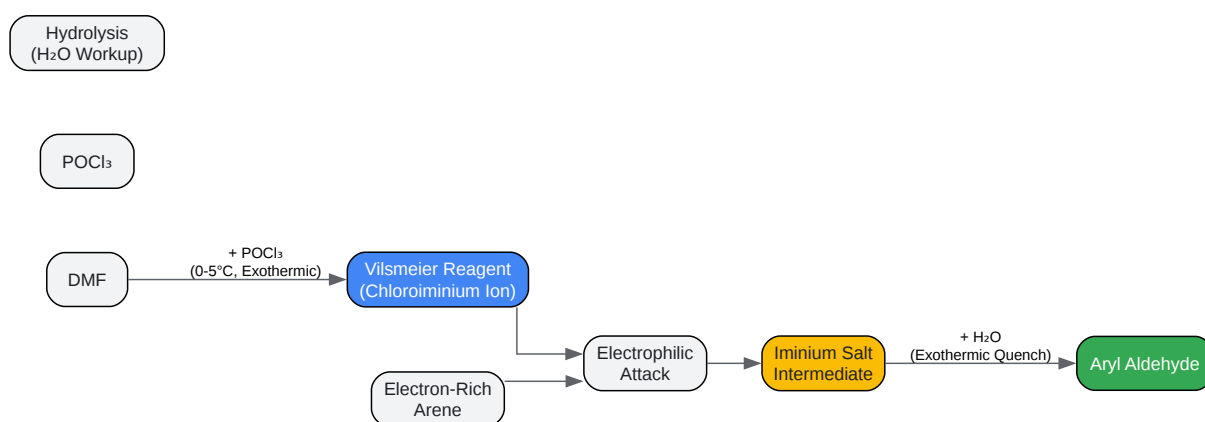

[Click to download full resolution via product page](#)

Caption: Key stages of the Vilsmeier-Haack reaction.

Troubleshooting Workflow for Low Yield

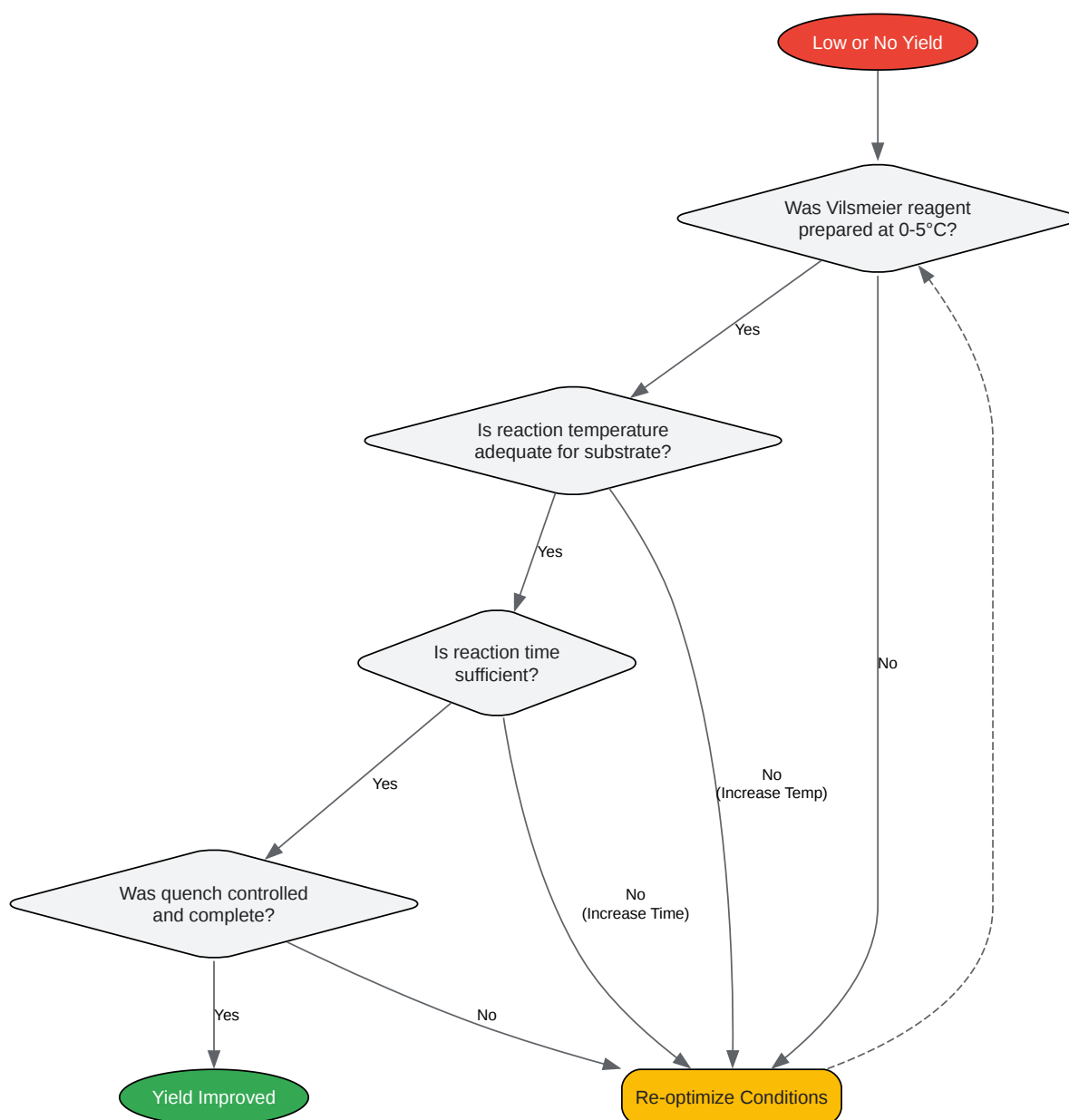

[Click to download full resolution via product page](#)

Caption: Decision tree for troubleshooting low yield.

References

- [7](#)
- [8](#)
- [11](#)
- [5](#)
- [2](#)
- [12](#)
- [3](#)
- [6](#)
- [13](#)
- [9](#)
- [14](#)
- [15](#)
- [16](#)
- [17](#)
- [18](#)
- [19](#)
- [20](#)
- [21](#)
- [22](#)

- [23](#)
- [1](#)
- [24](#)
- [25](#)
- [10](#)
- [26](#)
- [27](#)

Need Custom Synthesis?

BenchChem offers custom synthesis for rare earth carbides and specific isotopic labeling.

Email: info@benchchem.com or [Request Quote Online](#).

Sources

- [1. Vilsmeier–Haack reaction - Wikipedia \[en.wikipedia.org\]](#)
- [2. pdf.benchchem.com \[pdf.benchchem.com\]](#)
- [3. pdf.benchchem.com \[pdf.benchchem.com\]](#)
- [4. researchgate.net \[researchgate.net\]](#)
- [5. pdf.benchchem.com \[pdf.benchchem.com\]](#)
- [6. pdf.benchchem.com \[pdf.benchchem.com\]](#)
- [7. pdf.benchchem.com \[pdf.benchchem.com\]](#)
- [8. pdf.benchchem.com \[pdf.benchchem.com\]](#)
- [9. ijpcbs.com \[ijpcbs.com\]](#)
- [10. How To Run A Reaction \[chem.rochester.edu\]](#)
- [11. Vilsmeier-Haack Reaction | NROChemistry \[nrochemistry.com\]](#)
- [12. Vilsmeier-Haack Reaction \[organic-chemistry.org\]](#)

- [13. pdf.benchchem.com \[pdf.benchchem.com\]](https://pdf.benchchem.com)
- [14. vertexaisearch.cloud.google.com \[vertexaisearch.cloud.google.com\]](https://vertexaisearch.cloud.google.com)
- [15. Vilsmeier-Haack Reaction - Chemistry Steps \[chemistrysteps.com\]](https://chemistrysteps.com)
- [16. jk-sci.com \[jk-sci.com\]](https://jk-sci.com)
- [17. mt.com \[mt.com\]](https://mt.com)
- [18. reddit.com \[reddit.com\]](https://reddit.com)
- [19. Novel Synthetic Method for the Vilsmeier-Haack Reagent and Green Routes to Acid Chlorides, Alkyl Formates, and Alkyl Chlorides \[scirp.org\]](https://scirp.org)
- [20. pubs.acs.org \[pubs.acs.org\]](https://pubs.acs.org)
- [21. pubs.acs.org \[pubs.acs.org\]](https://pubs.acs.org)
- [22. pdf.benchchem.com \[pdf.benchchem.com\]](https://pdf.benchchem.com)
- [23. reddit.com \[reddit.com\]](https://reddit.com)
- [24. semanticscholar.org \[semanticscholar.org\]](https://semanticscholar.org)
- [25. growingscience.com \[growingscience.com\]](https://growingscience.com)
- [26. echemi.com \[echemi.com\]](https://echemi.com)
- [27. Organic Syntheses Procedure \[orgsyn.org\]](https://orgsyn.org)
- To cite this document: BenchChem. [Vilsmeier-Haack Reactions: A Technical Support Guide to Mastering Temperature Control]. BenchChem, [2026]. [Online PDF]. Available at: [\[https://www.benchchem.com/product/b1395934/docs#vilsmeier-haack-reactions-a-technical-support-guide-to-mastering-temperature-control\]](https://www.benchchem.com/product/b1395934/docs#vilsmeier-haack-reactions-a-technical-support-guide-to-mastering-temperature-control)

Disclaimer & Data Validity:

The information provided in this document is for Research Use Only (RUO) and is strictly not intended for diagnostic or therapeutic procedures. While BenchChem strives to provide accurate protocols, we make no warranties, express or implied, regarding the fitness of this product for every specific experimental setup.

Technical Support: The protocols provided are for reference purposes. Unsure if this reagent suits your experiment?

Need Industrial/Bulk Grade? [Request Custom Synthesis Quote](#)

BenchChem

Our mission is to be the trusted global source of essential and advanced chemicals, empowering scientists and researchers to drive progress in science and industry.

Contact

Address: 3281 E Guasti Rd

Ontario, CA 91761, United States

Phone: (601) 213-4426

Email: info@benchchem.com

[Contact our Ph.D. Support Team for a compatibility check](#)