

A Comparative Guide to the Efficacy of Palladium Catalysts in Pyrazole Synthesis

Author: BenchChem Technical Support Team. **Date:** January 2026

Compound of Interest

Compound Name: 2-Chloro-4-(1H-pyrazol-1-
YL)benzaldehyde

Cat. No.: B1395790

[Get Quote](#)

Introduction: The Pyrazole Core and the Power of Palladium

The pyrazole motif is a cornerstone in modern medicinal chemistry and materials science. Its unique electronic properties and ability to participate in hydrogen bonding have cemented its status as a privileged scaffold in numerous FDA-approved drugs. The efficient synthesis of functionalized pyrazoles is, therefore, a critical endeavor for researchers in drug development. Among the myriad of synthetic methods, palladium-catalyzed cross-coupling reactions have emerged as a highly versatile and powerful tool for both the initial construction of the pyrazole ring and its subsequent elaboration.^[1]

The choice of the palladium catalyst system—comprising a palladium precursor and a carefully selected ligand—is paramount to the success of these transformations. It directly influences reaction yields, substrate scope, functional group tolerance, and overall efficiency.^[2] This guide provides an in-depth, objective comparison of common palladium catalysts for pyrazole synthesis, supported by experimental data, to empower researchers to make informed decisions for their specific synthetic challenges. We will explore two primary applications: the formation of the pyrazole ring via C-N bond formation and the functionalization of pre-formed pyrazoles via C-C bond formation.

Part 1: Ring Formation via C-N Coupling - The Buchwald-Hartwig Amination

The Buchwald-Hartwig amination is a pillar of modern organic synthesis, enabling the formation of C-N bonds with remarkable efficiency.^{[2][3]} In pyrazole synthesis, it is often employed to couple an aryl halide with a hydrazine or a pyrazole anion. The efficacy of this reaction is critically dependent on the ligand coordinated to the palladium center. Bulky, electron-rich phosphine ligands are particularly effective as they promote the key steps of the catalytic cycle: oxidative addition and reductive elimination.^{[2][4]}

Comparative Performance of Catalyst Systems

The selection of the palladium precursor (e.g., Pd(OAc)₂, Pd₂(dba)₃) and the ligand dictates the catalyst's performance. Below is a comparative summary of various catalyst systems for the N-arylation of pyrazoles, a common strategy in drug discovery.

Pd Precursor	Ligand	Base	Solvent	Temp. (°C)	Time (h)	Typical Yield (%)	Key Advantages & Considerations
Pd(OAc) ₂	XPhos	K ₃ PO ₄	t-BuOH	110	3-12	85-98	Highly active for a broad range of aryl chlorides and bromides. Low catalyst loadings are often possible. [4]
Pd ₂ (dba) ₃	Xantphos	Cs ₂ CO ₃	Dioxane	100	12-24	75-92	Wide bite angle of Xantphos is effective for many substrates. [5] Often used for challenging couplings.
Pd(OAc) ₂	SPhos	K ₂ CO ₃	Toluene	100	4-18	80-95	Another highly active

Buchwald ligand, often showing complementary reactivity to XPhos. [4]

PdCl₂(dppf)

(dppf)

NaOt-Bu

Toluene

110

18-36

60-85

A more traditional catalyst system, generally reliable for aryl bromides and iodides but less effective for chlorides. [6]

Causality Behind Experimental Choices:

- **Ligand Choice:** The steric bulk of ligands like XPhos and SPhos facilitates the final reductive elimination step, which is often rate-limiting, thereby increasing the overall reaction rate.[4] Their electron-rich nature enhances the rate of oxidative addition of the aryl halide to the Pd(0) center.
- **Base Selection:** A strong, non-nucleophilic base like sodium tert-butoxide (NaOt-Bu) or potassium phosphate (K₃PO₄) is crucial.[2] The base deprotonates the pyrazole or

hydrazine, generating the active nucleophile, and facilitates the regeneration of the Pd(0) catalyst at the end of the cycle.

- Solvent: Aprotic, non-polar to polar aprotic solvents like toluene or dioxane are typically used to ensure the solubility of the reactants and catalyst system while remaining inert to the reaction conditions.

Illustrative Catalytic Cycle: Buchwald-Hartwig Amination

The mechanism involves a Pd(0)/Pd(II) catalytic cycle. Understanding this cycle is key to troubleshooting and optimizing reactions.

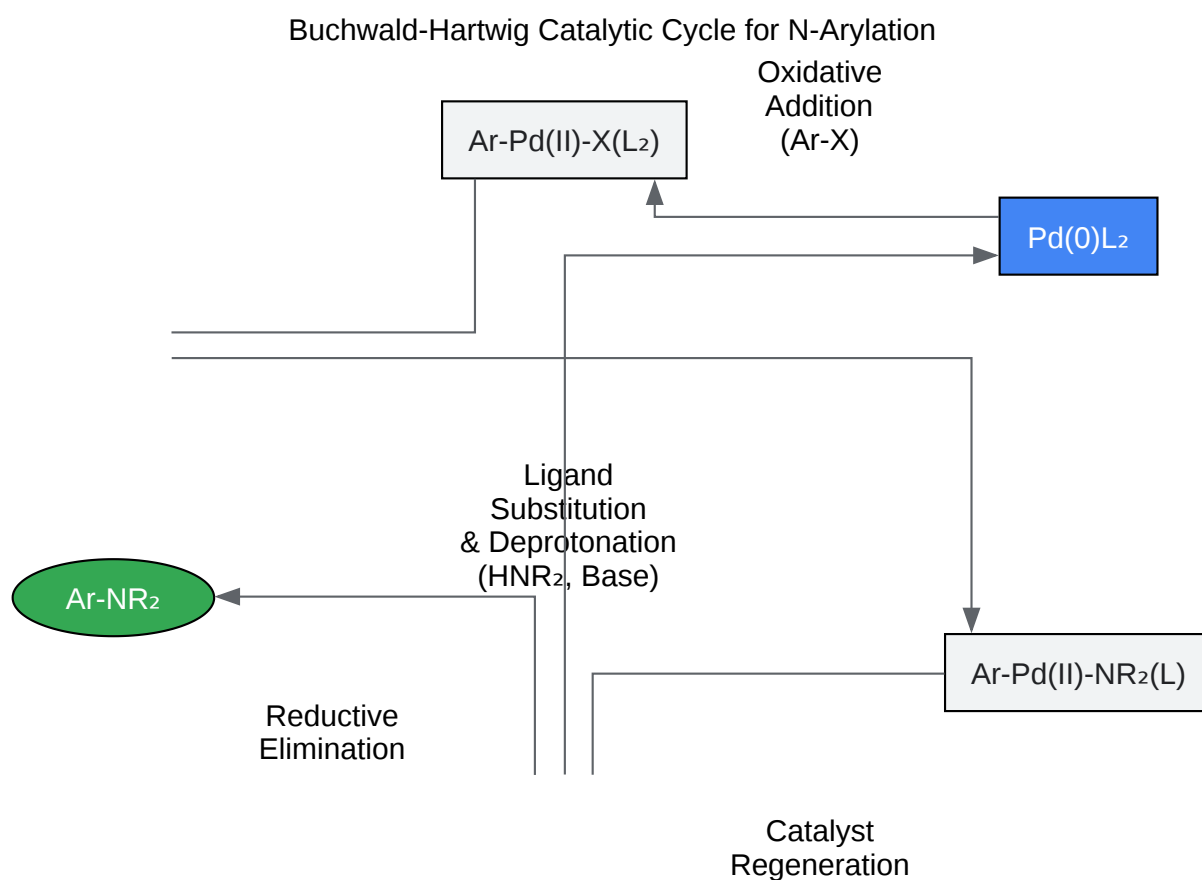

[Click to download full resolution via product page](#)

Caption: Generalized catalytic cycle for the Buchwald-Hartwig C-N coupling.

Part 2: Pyrazole Functionalization via C-C Coupling - The Suzuki-Miyaura Reaction

Once the pyrazole core is synthesized, its functionalization is often the next critical step. The Suzuki-Miyaura reaction is arguably the most widely used palladium-catalyzed cross-coupling reaction for forming C(sp²)-C(sp²) bonds, allowing for the introduction of aryl, heteroaryl, or vinyl substituents onto a halopyrazole scaffold.[1]

Comparative Efficacy of Catalysts in Suzuki Coupling of Halopyrazoles

The reactivity of halopyrazoles follows the expected trend (I > Br > Cl), with chloropyrazoles being the most challenging substrates.[6] The choice of catalyst is therefore highly dependent on the nature of the halide.

Pd Precursor /Precatalyst	Ligand/System	Base	Solvent	Temp. (°C)	Typical Yield (%)	Key Advantages & Considerations
Pd(PPh ₃) ₄	PPh ₃ (in situ)	Na ₂ CO ₃	Toluene/H ₂ O	90-100	80-95 (for I, Br)	A classic, reliable "workhorse" catalyst. Air-sensitive and may require higher catalyst loadings. Less effective for chlorides. [7]
PdCl ₂ (dppf)	dppf	K ₂ CO ₃	Dioxane	80-100	85-98 (for I, Br)	Highly reliable and versatile for a wide range of aryl bromides and iodides. [6] [7]
Pd(OAc) ₂ / SPhos	SPhos	K ₃ PO ₄	Toluene/H ₂ O	100	90-99 (for Br, Cl)	Excellent for challenging substrates,

including sterically hindered partners and unactivated aryl chlorides. [4]

The electron-rich and bulky tri-cyclohexyl phosphine ligand is particularly effective for activating stubborn C-Cl bonds.[8]

$\text{PdCl}_2(\text{PCy}_3)_2$	PCy_3	K_3PO_4	Dioxane	100-120	70-90 (for Cl)
---------------------------------	----------------	-------------------------	---------	---------	----------------

Causality Behind Experimental Choices:

- Catalyst System for Chlorides: The C-Cl bond is significantly stronger than C-Br or C-I bonds, making the initial oxidative addition step more difficult. Highly electron-rich and sterically demanding ligands like SPhos or PCy_3 are required to create a more reactive, coordinatively unsaturated Pd(0) species that can break this stronger bond.[4][9]
- Biphasic vs. Anhydrous Conditions: The use of an aqueous base (e.g., Na_2CO_3 in toluene/ H_2O) is common for Suzuki reactions as it facilitates the dissolution of the inorganic base and the boronic acid salt. Anhydrous conditions with bases like K_3PO_4 in dioxane are also highly effective, particularly for moisture-sensitive substrates.

Experimental Workflow: Catalyst Screening for Optimal Pyrazole Functionalization

A systematic approach is crucial for identifying the optimal catalyst system for a novel substrate.

Workflow for Catalyst System Optimization

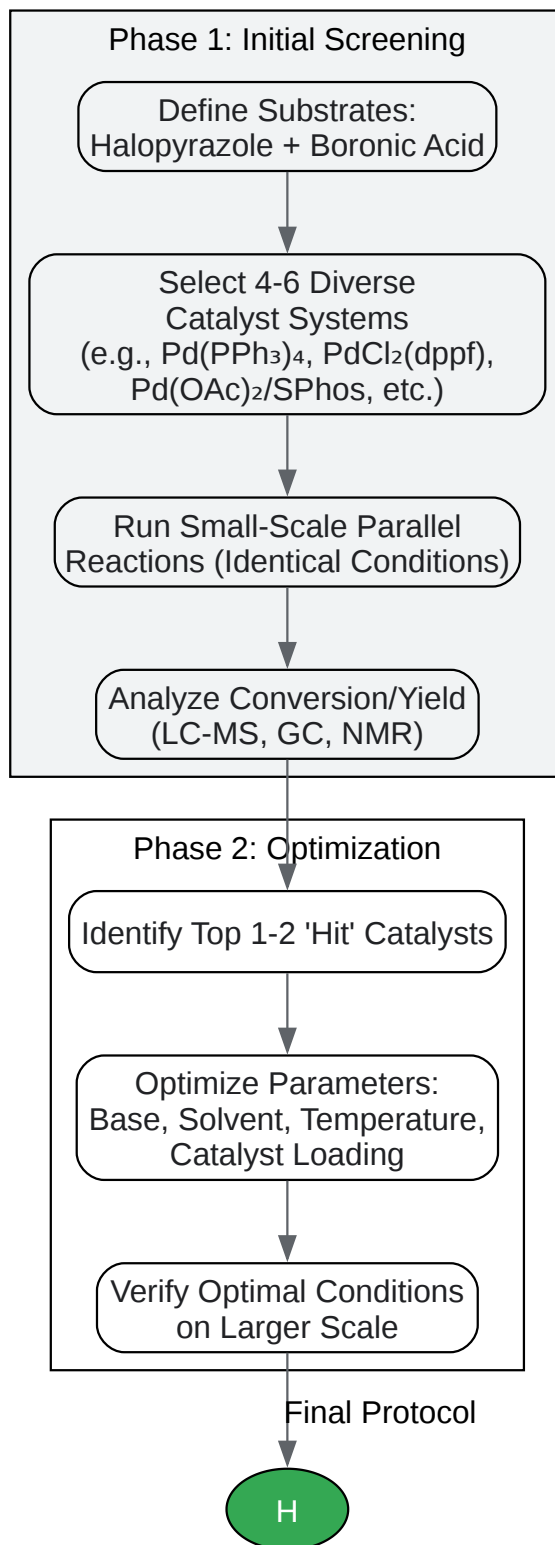

[Click to download full resolution via product page](#)

Caption: A logical workflow for efficient catalyst screening and reaction optimization.

Detailed Experimental Protocol: Suzuki-Miyaura Coupling of 4-Bromo-1-methyl-1H-pyrazole

This protocol provides a self-validating system for a typical Suzuki coupling reaction using a robust and reliable catalyst.

Materials:

- 4-Bromo-1-methyl-1H-pyrazole (1.0 equiv)
- Arylboronic acid (1.2 equiv)
- PdCl₂(dppf)·CH₂Cl₂ (0.03 equiv)
- Potassium Carbonate (K₂CO₃) (3.0 equiv)
- 1,4-Dioxane (anhydrous)
- Water (degassed)

Procedure:

- To a flame-dried Schlenk flask under an inert atmosphere (Argon or Nitrogen), add 4-bromo-1-methyl-1H-pyrazole, the arylboronic acid, PdCl₂(dppf)·CH₂Cl₂, and K₂CO₃.
- Evacuate and backfill the flask with the inert gas three times.
- Add anhydrous 1,4-dioxane and degassed water to achieve a 4:1 solvent ratio (e.g., 4 mL dioxane, 1 mL water).
- Heat the reaction mixture to 90 °C with vigorous stirring.
- Monitor the reaction progress by a suitable technique (e.g., TLC or LC-MS). Typical reaction times are 4-12 hours.
- Upon completion, cool the reaction to room temperature and dilute with ethyl acetate.

- Wash the organic layer with water and brine, then dry over anhydrous sodium sulfate (Na_2SO_4).
- Concentrate the solution under reduced pressure and purify the crude product by flash column chromatography on silica gel.

Conclusion and Future Outlook

The judicious selection of a palladium catalyst is a critical parameter that dictates the success of pyrazole synthesis and functionalization. For C-N bond formation via Buchwald-Hartwig amination, modern catalyst systems based on bulky, electron-rich phosphine ligands such as XPhos and SPhos offer superior performance, especially for challenging substrates.[2][4] For C-C bond formation via Suzuki-Miyaura coupling, traditional catalysts like $\text{Pd}(\text{PPh}_3)_4$ and $\text{PdCl}_2(\text{dppf})$ remain highly effective for bromo- and iodopyrazoles, while advanced systems are required to efficiently couple the more economical but less reactive chloropyrazoles.[6][7][9]

The field continues to evolve, with ongoing research focused on developing more active and stable catalysts that can operate at lower loadings and milder conditions. The emergence of palladium precatalysts, which offer enhanced stability and ease of handling, represents a significant step forward.[10] As the demand for complex, pyrazole-containing molecules grows, so too will the innovation in palladium catalysis, enabling chemists to build these vital structures with ever-increasing precision and efficiency.

Need Custom Synthesis?

BenchChem offers custom synthesis for rare earth carbides and specific isotopic labeling.

Email: info@benchchem.com or [Request Quote Online](#).

References

1. mdpi.com [mdpi.com]
2. benchchem.com [benchchem.com]
3. Buchwald–Hartwig amination - Wikipedia [en.wikipedia.org]
4. Highly Active Palladium Catalysts for Suzuki Coupling Reactions [organic-chemistry.org]

- 5. Synthesis of New N-Arylpyrimidin-2-amine Derivatives Using a Palladium Catalyst - PMC [pmc.ncbi.nlm.nih.gov]
- 6. benchchem.com [benchchem.com]
- 7. benchchem.com [benchchem.com]
- 8. researchgate.net [researchgate.net]
- 9. researchgate.net [researchgate.net]
- 10. Differences in the Performance of Allyl Based Palladium Precatalysts for Suzuki-Miyaura Reactions - PMC [pmc.ncbi.nlm.nih.gov]
- To cite this document: BenchChem. [A Comparative Guide to the Efficacy of Palladium Catalysts in Pyrazole Synthesis]. BenchChem, [2026]. [Online PDF]. Available at: [https://www.benchchem.com/product/b1395790#comparing-the-efficacy-of-palladium-catalysts-in-pyrazole-synthesis]

Disclaimer & Data Validity:

The information provided in this document is for Research Use Only (RUO) and is strictly not intended for diagnostic or therapeutic procedures. While BenchChem strives to provide accurate protocols, we make no warranties, express or implied, regarding the fitness of this product for every specific experimental setup.

Technical Support: The protocols provided are for reference purposes. Unsure if this reagent suits your experiment? [[Contact our Ph.D. Support Team for a compatibility check](#)]

Need Industrial/Bulk Grade? [Request Custom Synthesis Quote](#)

BenchChem

Our mission is to be the trusted global source of essential and advanced chemicals, empowering scientists and researchers to drive progress in science and industry.

Contact

Address: 3281 E Guasti Rd
Ontario, CA 91761, United States
Phone: (601) 213-4426
Email: info@benchchem.com