

Application Note: Tracing Xenobiotic Fate with 3-Chlorotoluene-D7

Author: BenchChem Technical Support Team. **Date:** May 2026

Compound of Interest

Compound Name: 3-Chlorotoluene-D7

Cat. No.: B13948094

[Get Quote](#)

A Guide to In Vivo Metabolic Tracer Analysis for Drug Development and Toxicology

Introduction: The Imperative of Isotope Tracers in Modern Research

Understanding the absorption, distribution, metabolism, and excretion (ADME) of novel chemical entities is a cornerstone of modern drug development and toxicological assessment. Stable isotope labeling is a powerful and safe technique that allows researchers to trace the metabolic fate of a compound without the risks associated with radioactive isotopes.[1][2] By replacing hydrogen atoms with their stable, heavier isotope deuterium (^2H), we create a tracer that is chemically identical to the parent molecule but physically distinguishable by mass spectrometry.[2][3]

This application note provides a comprehensive guide to using **3-Chlorotoluene-D7**, a deuterated aromatic hydrocarbon, as a model tracer for xenobiotic metabolism studies. While 3-Chlorotoluene itself is an industrial chemical intermediate, its metabolic pathways serve as an excellent proxy for understanding how the mammalian body processes a class of chlorinated aromatic compounds.[4][5][6] This guide is designed for researchers in pharmacology,

toxicology, and drug metabolism, offering both the theoretical underpinnings and a detailed, field-proven protocol for an in vivo rodent study.

Core Principle: The seven deuterium atoms on **3-Chlorotoluene-D7** create a distinct mass shift (+7 Da) from the endogenous, unlabeled counterpart. This mass difference allows for the unambiguous detection and quantification of the tracer and its downstream metabolites against a complex biological background using mass spectrometry.

Scientific Rationale and Mechanistic Insights

Why Use a Stable Isotope Tracer?

Stable isotope tracers offer unparalleled precision and safety in metabolic research.^{[2][7]} Unlike radiolabeling, they do not require specialized handling for radiation, making studies logistically simpler and safer. The key advantages include:

- **High Specificity:** Mass spectrometry can easily differentiate the deuterated tracer from endogenous compounds, eliminating background noise.
- **Quantitative Accuracy:** When used with a corresponding non-labeled internal standard, deuterated compounds allow for highly accurate quantification, correcting for variations in sample preparation and instrument response.^{[8][9]}
- **Dynamic Flux Information:** Isotope tracing provides a dynamic view of metabolic pathways, revealing the rates of conversion and the flow of atoms through the network, which cannot be gleaned from simple concentration measurements alone.^{[7][10][11]}

Predicted Metabolic Fate of 3-Chlorotoluene

The metabolism of aromatic hydrocarbons like 3-chlorotoluene is primarily handled by the cytochrome P450 (CYP450) enzyme system in the liver.^[12] Based on established biotransformation pathways for similar compounds, we can predict two major routes of metabolism.^{[12][13][14]}

- **Side-Chain Oxidation:** The methyl group is a primary target for oxidation, a common Phase I reaction.^[12] This process, catalyzed by CYP450, is expected to form 3-chlorobenzyl alcohol, which can be further oxidized to 3-chlorobenzoic acid.^[13]

- Aromatic Ring Hydroxylation: The aromatic ring can also be oxidized to form an epoxide intermediate, which then rearranges to form various chloromethylphenols.[12][14]

These primary metabolites can then undergo Phase II conjugation reactions (e.g., glucuronidation or sulfation) to increase their water solubility and facilitate excretion.[14] Our use of **3-Chlorotoluene-D7** will allow us to track the deuterium label as it is retained on these various metabolic products.

Below is a conceptual diagram illustrating the principle of using **3-Chlorotoluene-D7** as a tracer.

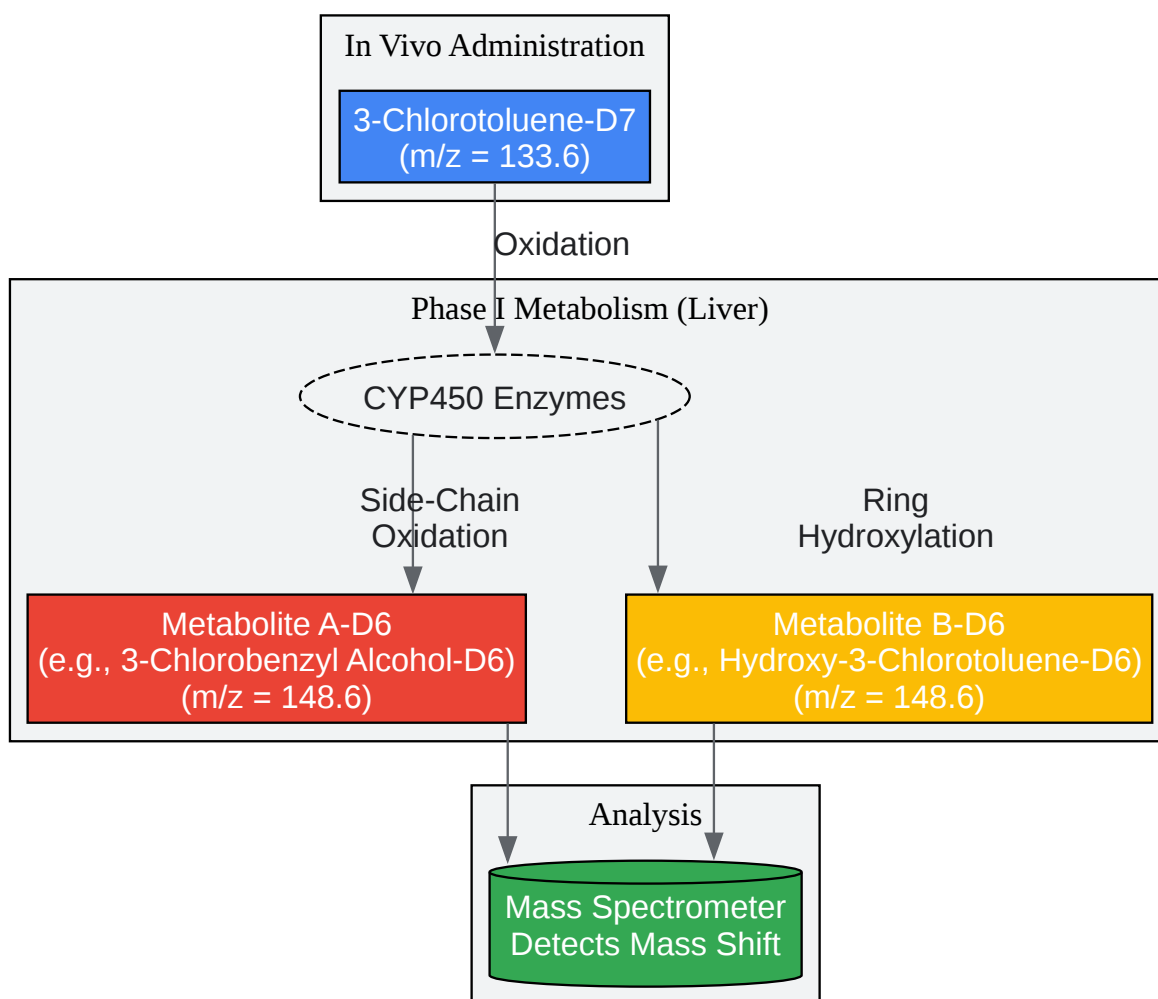

[Click to download full resolution via product page](#)

Caption: Metabolic tracing workflow for **3-Chlorotoluene-D7**.

Detailed Experimental Protocol: In Vivo Rodent Study

This protocol outlines a complete workflow for a rodent study, from tracer administration to sample analysis. It is designed to be a self-validating system by including necessary controls and standards.

Materials and Reagents

Reagent/Material	Specifications
Test Article	3-Chlorotoluene-D7 (Isotopic Purity >98%)[9]
Vehicle	Corn oil
Internal Standard (IS)	3-Chlorotoluene (unlabeled, analytical grade)
Test Subjects	Male Sprague-Dawley rats (8-10 weeks old)
Extraction Solvent	Acetonitrile (HPLC grade), ice-cold
Sample Collection	K2-EDTA tubes (for blood), Metabolic cages (for urine/feces)
Instrumentation	Gas Chromatograph with Mass Spectrometer (GC-MS)

Study Design and Dosing

Rationale: This design allows for the collection of time-course data to understand the pharmacokinetics of the tracer and its metabolites. The U.S. Food and Drug Administration (FDA) recommends collecting samples at multiple time points to accurately model uptake and elimination.[15]

- Acclimatization: Acclimate animals for at least 7 days prior to the study.
- Grouping: Divide animals into treatment groups (n=5 per time point).

- Dose Preparation: Prepare a dosing solution of **3-Chlorotoluene-D7** in corn oil at a concentration of 10 mg/mL.
- Administration: Administer a single oral gavage dose of 100 mg/kg to each rat.
- Sample Collection: Collect blood and urine at the following time points: 0 (pre-dose), 1, 2, 4, 8, and 24 hours post-dose. Blood should be collected via tail vein or saphenous vein into K2-EDTA tubes.[15]

Step-by-Step Sample Preparation Protocol

Principle: 3-Chlorotoluene is a volatile organic compound (VOC).[6] The sample preparation method must be optimized to extract the analyte and its metabolites from a complex biological matrix (blood) while preventing evaporative loss. Protein precipitation with ice-cold acetonitrile is a robust method for crashing out proteins and releasing small molecules into the solvent.

- Spiking the Internal Standard (IS):
 - To 200 μ L of whole blood in a 2 mL microcentrifuge tube, add 10 μ L of a 1 μ g/mL solution of unlabeled 3-Chlorotoluene in methanol. The IS is crucial for correcting analytical variability.
- Protein Precipitation:
 - Add 600 μ L of ice-cold acetonitrile to the tube.
 - Rationale: Acetonitrile is an effective protein precipitant and is miscible with blood. Using it cold enhances the precipitation efficiency.
- Vortexing:
 - Vortex the tube vigorously for 60 seconds to ensure complete mixing and protein denaturation.
- Centrifugation:
 - Centrifuge at 14,000 x g for 10 minutes at 4°C.

- Rationale: This step pellets the precipitated proteins, leaving the supernatant containing the analytes of interest.
- Supernatant Transfer:
 - Carefully transfer the supernatant to a new, clean 1.5 mL tube.
- Evaporation (Optional but Recommended):
 - Concentrate the sample under a gentle stream of nitrogen at room temperature to a final volume of ~100 μ L. Do not evaporate to complete dryness to avoid loss of the volatile analyte.
- Final Transfer:
 - Transfer the final extract to a GC-MS autosampler vial with a glass insert.

GC-MS Analytical Method

Principle: Gas chromatography is the ideal separation technique for volatile and semi-volatile compounds like chlorotoluenes.^{[16][17]} A mass spectrometer serves as the detector, allowing for the selective monitoring of ions specific to our tracer and its metabolites.

GC-MS Parameter	Setting	Rationale
GC Column	DB-5ms (30m x 0.25mm, 0.25µm) or equivalent	A non-polar column that provides excellent separation for aromatic compounds.
Inlet Temperature	250°C	Ensures rapid volatilization of the sample.
Injection Mode	Splitless (1 µL injection)	Maximizes the amount of analyte transferred to the column for trace-level detection.
Oven Program	50°C (hold 2 min), ramp to 280°C at 15°C/min, hold 5 min	Provides good separation between the parent compound and potential metabolites.
Carrier Gas	Helium, constant flow at 1.2 mL/min	Inert carrier gas standard for GC-MS.
MS Source Temp.	230°C	Standard temperature for electron ionization.
MS Quad Temp.	150°C	Standard temperature for quadrupole mass filter.
Ionization Mode	Electron Ionization (EI) at 70 eV	Standard, robust ionization method that produces reproducible fragmentation patterns.
Acquisition Mode	Selected Ion Monitoring (SIM)	Increases sensitivity by monitoring only specific ions of interest.

Selected Ion Monitoring (SIM) Table:

Compound	Quantifier Ion (m/z)	Qualifier Ion (m/z)
3-Chlorotoluene (IS)	126	91
3-Chlorotoluene-D7	133	98
Putative Metabolite (e.g., 3-Chlorobenzyl alcohol-D6)	148	112

Rationale for Ion Selection: The molecular ion (M^+) is often chosen for quantification as it is the most specific. For 3-Chlorotoluene, the base peak is often the tropylium ion (m/z 91) formed by loss of chlorine. For the D7 version, this fragment shifts to m/z 98. Monitoring both quantifier and qualifier ions increases confidence in peak identification.

Data Analysis and Interpretation

- **Peak Integration:** Integrate the chromatographic peaks for the quantifier ions of the internal standard (m/z 126) and the tracer (m/z 133) at each time point.
- **Response Ratio Calculation:** Calculate the response ratio for each sample: (Peak Area of Tracer) / (Peak Area of IS).
- **Calibration Curve:** Prepare a calibration curve using standards of known **3-Chlorotoluene-D7** concentrations spiked into blank blood and processed through the same extraction procedure. Plot the response ratio against concentration and perform a linear regression.
- **Quantification:** Determine the concentration of the tracer in the unknown samples by using the regression equation from the calibration curve.
- **Metabolite Identification:** Scan the chromatograms for peaks that appear post-dose and contain the expected mass shift. For example, a hydroxylated metabolite would have a molecular ion that is 16 Da higher than the parent tracer, while retaining the deuterium label. Full scan (non-SIM) acquisitions on pooled high-concentration samples may be necessary to identify unknown metabolites.

The overall experimental and analytical workflow is summarized in the diagram below.

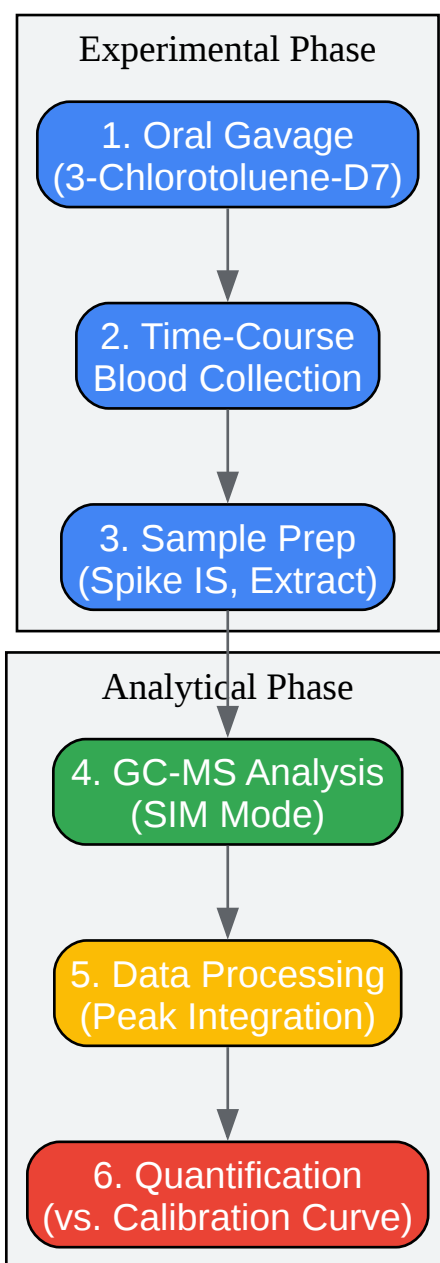

[Click to download full resolution via product page](#)

Caption: Overall workflow from animal dosing to final data quantification.

References

- U.S. Food and Drug Administration. Metabolism and Pharmacokinetic Studies. Available at: [\[Link\]](#)

- Antoniewicz, M. R. (2022). Isotope-Assisted Metabolic Flux Analysis: A Powerful Technique to Gain New Insights into the Human Metabolome in Health and Disease. PubMed Central. Available at: [\[Link\]](#)
- Bertoni, G., et al. (1996). Metabolism of Chlorotoluenes by Burkholderia sp. Strain PS12 and Toluene Dioxygenase of Pseudomonas putida F1. PubMed. Available at: [\[Link\]](#)
- PubChem. 3-Chlorotoluene. National Center for Biotechnology Information. Available at: [\[Link\]](#)
- Narayanan, B., et al. ANAEROBIC BIOTRANSFORMATION OF AROMATIC AND POLYCYCLIC AROMATIC HYDROCARBONS IN SOIL MICROCOSMS: A REVIEW. Kansas State University. Available at: [\[Link\]](#)
- Lin, G., & Gu, J. (2008). Application of stable isotope-labeled compounds in metabolism and in metabolism-mediated toxicity studies. PubMed. Available at: [\[Link\]](#)
- Crown, S. B., & Antoniewicz, M. R. (2013). Parallel labeling experiments and metabolic flux analysis: past, present and future methodologies. PubMed Central. Available at: [\[Link\]](#)
- Jang, C., et al. (2018). Measurement of metabolic fluxes using stable isotope tracers in whole animals and human patients. PubMed Central. Available at: [\[Link\]](#)
- Ihedioha, O. S., et al. (2018). A REVIEW: USE OF DEUTERATED INTERNAL STANDARDS IN MASS SPECTROMETRY TECHNIQUES.
- ResolveMass Laboratories Inc. (2025). Deuterated Standards for LC-MS Analysis. Available at: [\[Link\]](#)
- Ladino-Orjuela, G., et al. (2016). Metabolic Pathways for Degradation of Aromatic Hydrocarbons by Bacteria. In: Villa, T., & Tejeda-Sartorius, O. (eds) Food Borne Pathogens and Antibiotic Resistance. Springer, Cham.
- Becatti, M., et al. (2025). A Novel Sample Preparation Method for GC-MS Analysis of Volatile Organic Compounds in Whole Blood for Veterinary Use. PubMed. Available at: [\[Link\]](#)
- Metabolic Solutions. (2024). Introduction to Stable Isotope Labeling and How It Supports Drug Development for Rare Diseases. Available at: [\[Link\]](#)

- U.S. Food and Drug Administration. (2020). Safety Testing of Drug Metabolites Guidance for Industry. Available at: [\[Link\]](#)
- Moormann, M., et al. (2006). Chloromethylmuconolactones as Critical Metabolites in the Degradation of Chloromethylcatechols: Recalcitrance of 2-Chlorotoluene. PubMed Central. Available at: [\[Link\]](#)
- Boros, B., & Jones, J. G. (2020). Tracing metabolic flux through time and space with isotope labeling experiments. PubMed Central. Available at: [\[Link\]](#)
- Rickert, D. E., & Held, S. D. (1990). Metabolism of chloronitrobenzenes by isolated rat hepatocytes. PubMed. Available at: [\[Link\]](#)
- Ladino-Orjuela, G., et al. (2016). Metabolic Pathways for Degradation of Aromatic Hydrocarbons by Bacteria. ResearchGate. Available at: [\[Link\]](#)
- Lin, G., & Gu, J. (2008). Application of Stable Isotope-Labeled Compounds in Metabolism and in Metabolism-Mediated Toxicity Studies. ACS Publications. Available at: [\[Link\]](#)
- OECD. (2003). p-CHLOROTOLUENE CAS N°: 106-43-4. OECD Existing Chemicals Database. Available at: [\[Link\]](#)
- ResolveMass Laboratories Inc. (2025). Deuterated Internal Standards for LC-MS: Selection & Custom Synthesis. YouTube. Available at: [\[Link\]](#)
- U.S. Food and Drug Administration. FDA Draft Guidance: Clinical Pharmacology Considerations for Human Radiolabeled Mass Balance Studies. Regulations.gov. Available at: [\[Link\]](#)
- Centers for Disease Control and Prevention. Volatile Organic Compounds (VOCs) in Whole Blood. Available at: [\[Link\]](#)
- Edwards, E., & Grbic-Galic, D. (1995). Biotransformation of aromatic hydrocarbons in subsurface biofilms. Water Science & Technology. Available at: [\[Link\]](#)
- CSL Behring. Benefits of ¹³C vs. D Standards in Clinical Mass Spectrometry Measurements. Available at: [\[Link\]](#)

- Bas-Orth, C., et al. (2020). Spatially resolved metabolomics and isotope tracing reveal dynamic metabolic responses of dentate granule neurons with acute stimulation. PubMed Central. Available at: [\[Link\]](#)
- Duca, R. C., et al. (2025). (PDF) Chromatographic determination of toluene and its metabolites in urine for toluene exposure – A review. ResearchGate. Available at: [\[Link\]](#)
- Yang, T. H., et al. (2020). Metabolic Flux Analysis—Linking Isotope Labeling and Metabolic Fluxes. MDPI. Available at: [\[Link\]](#)
- Federal Register. (2022). Clinical Pharmacology Considerations for Human Radiolabeled Mass Balance Studies; Draft Guidance for Industry; Availability. Available at: [\[Link\]](#)
- Badding, M. A., et al. (2021). In vitro and in vivo assessments of the genotoxic potential of 3-chloroallyl alcohol. PubMed Central. Available at: [\[Link\]](#)
- Yuan, J., et al. (2012). Metabolomics and isotope tracing. PubMed Central. Available at: [\[Link\]](#)
- Agency for Toxic Substances and Disease Registry. ANALYTICAL METHODS - Toxicological Profile for Toluene. NCBI Bookshelf. Available at: [\[Link\]](#)
- Agency for Toxic Substances and Disease Registry. (2018). chapter 3. toxicokinetics, susceptible populations, biomarkers, chemical interactions. Available at: [\[Link\]](#)
- JoVE. (2025). Phase I Reactions: Oxidation of Aliphatic and Aromatic Carbon-Containing Systems. Available at: [\[Link\]](#)
- Yang, T. H., et al. (2020). Metabolic Flux Analysis—Linking Isotope Labeling and Metabolic Fluxes. ResearchGate. Available at: [\[Link\]](#)
- Owen, L. J., & Keevil, B. G. (2013). Potential problems with using deuterated internal standards for liquid chromatography-tandem mass spectrometry. ResearchGate. Available at: [\[Link\]](#)
- Chemicals Knowledge Hub. (2023). The importance of isotopic labelling in drug development: strategies and integration with biocatalysis and physical sciences. Available at:

[\[Link\]](#)

- ProSciento. Isotope Tracer Methodologies for Metabolic Clinical Trials. Available at: [\[Link\]](#)
- SCION Instruments. Sample preparation GC-MS. Available at: [\[Link\]](#)
- Creative Biolabs. Reactive Metabolite Analysis. Available at: [\[Link\]](#)
- Blount, B. C., et al. (2006). Quantification of 31 volatile organic compounds in whole blood using solid-phase microextraction and gas chromatography–mass spectrometry.

Need Custom Synthesis?

BenchChem offers custom synthesis for rare earth carbides and specific isotopic labeling.

Email: info@benchchem.com or [Request Quote Online](#).

Sources

1. Application of stable isotope-labeled compounds in metabolism and in metabolism-mediated toxicity studies - PubMed [pubmed.ncbi.nlm.nih.gov]
2. metsol.com [metsol.com]
3. Applications of Stable Isotope Labeling in Metabolic Flux Analysis - Creative Proteomics [creative-proteomics.com]
4. CAS 108-41-8: 3-Chlorotoluene | CymitQuimica [cymitquimica.com]
5. 3-Chlorotoluene 98% | Sigma-Aldrich [sigmaaldrich.com]
6. 3-Chlorotoluene | C7H7Cl | CID 7931 - PubChem [pubchem.ncbi.nlm.nih.gov]
7. Measurement of metabolic fluxes using stable isotope tracers in whole animals and human patients - PMC [pmc.ncbi.nlm.nih.gov]
8. texilajournal.com [texilajournal.com]
9. resolvemass.ca [resolvemass.ca]
10. Isotope-Assisted Metabolic Flux Analysis: A Powerful Technique to Gain New Insights into the Human Metabolome in Health and Disease - PMC [pmc.ncbi.nlm.nih.gov]
11. mdpi.com [mdpi.com]

- [12. Video: Phase I Reactions: Oxidation of Aliphatic and Aromatic Carbon-Containing Systems \[jove.com\]](#)
- [13. Metabolism of Chlorotoluenes by Burkholderia sp. Strain PS12 and Toluene Dioxygenase of Pseudomonas putida F1: Evidence for Monooxygenation by Toluene and Chlorobenzene Dioxygenases - PubMed \[pubmed.ncbi.nlm.nih.gov\]](#)
- [14. atsdr.cdc.gov \[atsdr.cdc.gov\]](#)
- [15. fda.gov \[fda.gov\]](#)
- [16. GC-MS Sample Preparation | Thermo Fisher Scientific - JP \[thermofisher.com\]](#)
- [17. Sample preparation GC-MS \[scioninstruments.com\]](#)
- To cite this document: BenchChem. [Application Note: Tracing Xenobiotic Fate with 3-Chlorotoluene-D7]. BenchChem, [2026]. [Online PDF]. Available at: [\[https://www.benchchem.com/product/b13948094/docs#application-note-tracing-xenobiotic-fate-with-3-chlorotoluene-d7\]](https://www.benchchem.com/product/b13948094/docs#application-note-tracing-xenobiotic-fate-with-3-chlorotoluene-d7)

Disclaimer & Data Validity:

The information provided in this document is for Research Use Only (RUO) and is strictly not intended for diagnostic or therapeutic procedures. While BenchChem strives to provide accurate protocols, we make no warranties, express or implied, regarding the fitness of this product for every specific experimental setup.

Technical Support: The protocols provided are for reference purposes. Unsure if this reagent suits your experiment?

Need Industrial/Bulk Grade? [Request Custom Synthesis Quote](#)

BenchChem

Our mission is to be the trusted global source of essential and advanced chemicals, empowering scientists and researchers to drive progress in science and industry.

Contact

Address: 3281 E Guasti Rd
Ontario, CA 91761, United States
Phone: (601) 213-4426
Email: info@benchchem.com

Contact our Ph.D. Support Team for a compatibility check