

A Comparative Guide to the Reaction Kinetics of 3-Propoxyprop-1-yne

Author: BenchChem Technical Support Team. **Date:** February 2026

Compound of Interest

Compound Name: 3-Propoxyprop-1-yne

CAS No.: 53135-64-1

Cat. No.: B13944666

[Get Quote](#)

For Researchers, Scientists, and Drug Development Professionals

Introduction: The Significance of 3-Propoxyprop-1-yne

3-Propoxyprop-1-yne belongs to the versatile class of propargyl ethers, which are crucial building blocks in organic synthesis.[1] The propargyl group, a three-carbon unit with a terminal alkyne, is a highly adaptable moiety that opens up numerous synthetic pathways for creating more complex molecules.[2] The presence of the ether linkage in **3-propoxyprop-1-yne** introduces unique electronic and steric properties that are anticipated to modulate the reactivity of the alkyne, making it a subject of interest in medicinal chemistry and materials science. Propargyl alcohols and their derivatives are known to be highly reactive intermediates for the synthesis of various heterocycles through cycloaddition and cycloisomerization reactions.[3]

Comparative Kinetics: 3-Propoxyprop-1-yne vs. Alternative Alkynes

The reactivity of a terminal alkyne is largely governed by the substituent at the propargylic position. In **3-propoxyprop-1-yne**, the propoxy group (-OCH₂CH₂CH₃) is expected to influence reaction rates through inductive and steric effects. We will compare its anticipated kinetic behavior to two common terminal alkynes: 1-hexyne (an alkyl-substituted alkyne) and phenylacetylene (an aryl-substituted alkyne).

Electronic Effects of the Propoxy Group:

The oxygen atom in the propoxy group is electron-withdrawing through induction, which can influence the acidity of the terminal proton and the electron density of the triple bond. This can affect the rates of various reactions:

- Deprotonation: The increased acidity of the terminal proton should lead to faster deprotonation rates compared to 1-hexyne, facilitating reactions like the Sonogashira coupling.
- Electrophilic Additions: The electron-withdrawing nature of the propoxy group may slightly decrease the nucleophilicity of the alkyne, potentially slowing down electrophilic addition reactions compared to 1-hexyne.^[4]

Steric Effects:

The propoxy group is bulkier than the hydrogen atom in acetylene or the methyl group in propyne, which can influence the approach of reagents to the reactive site. This steric hindrance may lead to slower reaction rates in sterically demanding transformations.

Below is a table summarizing the anticipated relative reaction rates for key alkyne reactions.

Reaction Type	3-Propoxyprop-1-yne (Predicted)	1-Hexyne (Alkyl)	Phenylacetylene (Aryl)	Rationale for Prediction
Sonogashira Coupling	Faster	Slower	Similar	The electron-withdrawing propoxy group increases the acidity of the terminal proton, facilitating the formation of the copper acetylide intermediate.[5]
Azide-Alkyne Cycloaddition (CuAAC)	Similar	Similar	Slower	The reaction is generally tolerant of a wide range of functional groups. Phenylacetylene can sometimes exhibit slightly slower rates due to electronic effects.[6]
Acid-Catalyzed Hydration	Slower	Faster	Faster	The electron-withdrawing propoxy group can destabilize the vinyl cation intermediate, slowing the reaction. Phenylacetylene is activated by

the phenyl group.

[7]

Diels-Alder
Cycloaddition

Similar

Similar

Faster

Alkynes are generally weak dienophiles. The electronic nature of the substituent can influence the rate, with electron-withdrawing groups sometimes accelerating the reaction.[8]

Experimental Protocols for Kinetic Studies

To validate the predicted kinetic behavior of **3-propoxyprop-1-yne**, rigorous experimental studies are necessary. The following are detailed protocols for monitoring the kinetics of alkyne reactions using common analytical techniques.

This protocol allows for the real-time monitoring of the consumption of **3-propoxyprop-1-yne** and the formation of the coupled product.

Materials:

- **3-Propoxyprop-1-yne**
- Aryl halide (e.g., iodobenzene)
- Palladium catalyst (e.g., Pd(PPh₃)₄)
- Copper(I) iodide (CuI)
- Amine base (e.g., triethylamine)

- Deuterated solvent (e.g., CDCl_3)
- NMR tubes
- Internal standard (e.g., 1,3,5-trimethoxybenzene)

Procedure:

- In a glovebox, prepare a stock solution of the palladium catalyst, CuI , and the internal standard in the deuterated solvent.
- To an NMR tube, add **3-propoxyprop-1-yne**, the aryl halide, and the amine base.
- Add a precise volume of the stock solution to the NMR tube to initiate the reaction.
- Immediately place the NMR tube in a pre-heated NMR spectrometer.[\[9\]](#)
- Acquire a series of ^1H NMR spectra at fixed time intervals.[\[10\]](#)
- Integrate the signals corresponding to the starting materials and the product relative to the internal standard.
- Plot the concentration of the reactants and products as a function of time to determine the reaction rate and order.[\[11\]](#)

Data Analysis: The reaction progress can be monitored by observing the disappearance of the acetylenic proton of **3-propoxyprop-1-yne** and the appearance of new aromatic and propargylic signals of the product.

This method is particularly useful for monitoring the disappearance of the azide and alkyne functional groups, which have distinct IR stretching frequencies.

Materials:

- **3-Propoxyprop-1-yne**
- Organic azide (e.g., benzyl azide)

- Copper(I) catalyst (e.g., copper(I) bromide)
- Ligand (e.g., TBTA)
- Solvent (e.g., THF)
- in situ IR probe

Procedure:

- Set up a reaction vessel equipped with an in situ IR probe and a temperature controller.[12]
- Charge the vessel with **3-propoxyprop-1-yne**, the organic azide, the ligand, and the solvent.
- Initiate the reaction by adding the copper(I) catalyst.
- Record the IR spectrum at regular time intervals.[13]
- Monitor the decrease in the intensity of the azide stretch ($\sim 2100\text{ cm}^{-1}$) and the alkyne C-H stretch ($\sim 3300\text{ cm}^{-1}$).[14]
- Convert the absorbance data to concentration using a pre-established calibration curve.
- Plot concentration versus time to determine the kinetic parameters.

This protocol is suitable for reactions that are slower and require separation of the components before analysis.

Materials:

- **3-Propoxyprop-1-yne**
- Sulfuric acid
- Mercury(II) sulfate
- Water
- Organic solvent for extraction (e.g., diethyl ether)

- Internal standard (e.g., dodecane)

Procedure:

- Set up a temperature-controlled reaction vessel.
- Add **3-propoxyprop-1-yne**, water, and the internal standard to the vessel.
- Initiate the reaction by adding the sulfuric acid and mercury(II) sulfate catalyst.[7]
- At specific time points, withdraw an aliquot of the reaction mixture and quench it with a saturated sodium bicarbonate solution.
- Extract the organic components with diethyl ether.
- Analyze the organic extract by GC-MS to determine the relative concentrations of the starting material and the ketone product.[15][16]
- Plot the concentration data against time to obtain the reaction rate.

Visualizing Reaction Mechanisms and Workflows

Visual representations are crucial for understanding complex chemical processes. The following diagrams, generated using Graphviz, illustrate a key reaction mechanism and a general experimental workflow for kinetic analysis.

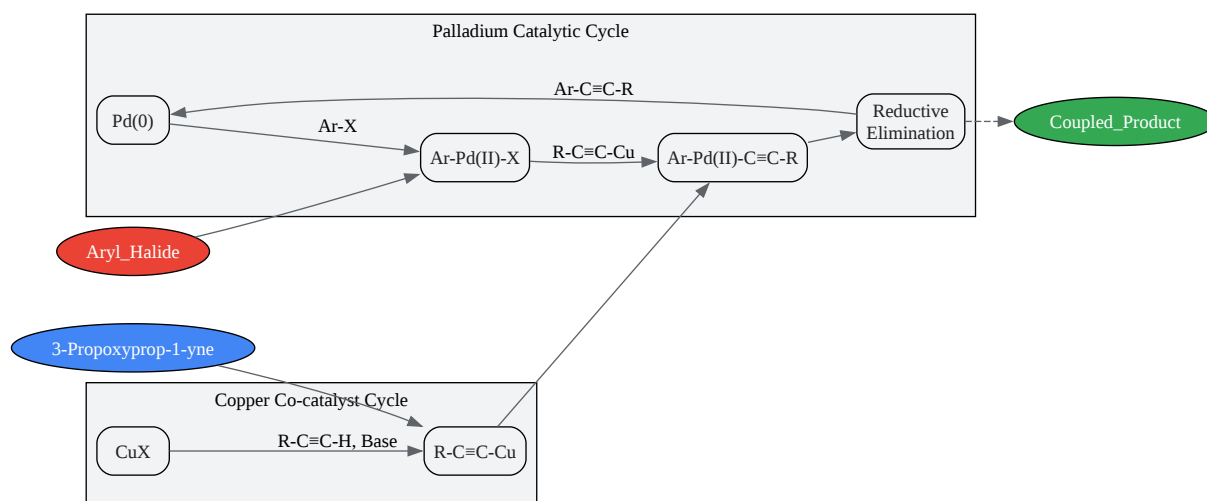

[Click to download full resolution via product page](#)

Caption: Simplified mechanism of the Sonogashira coupling reaction.

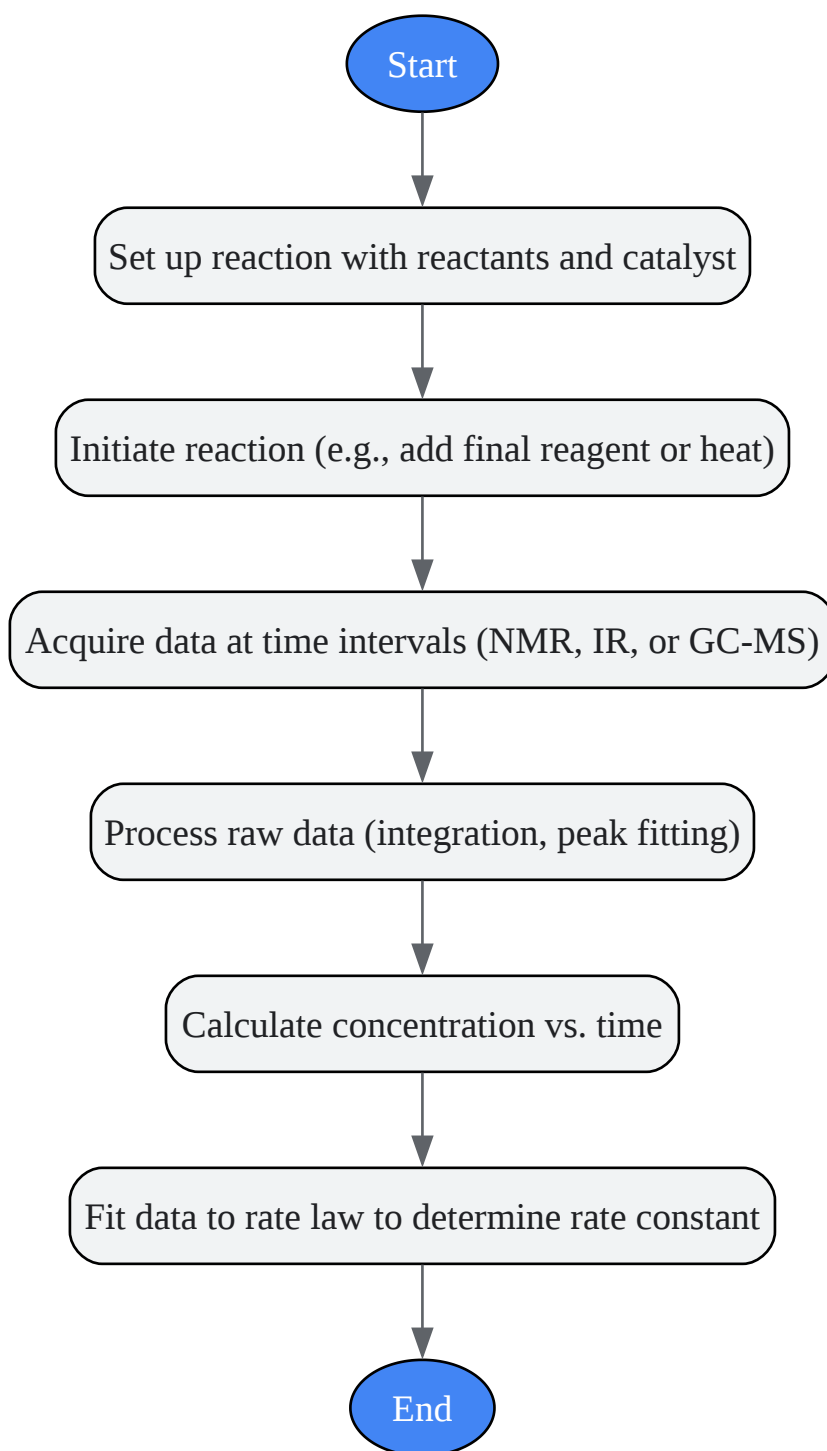

[Click to download full resolution via product page](#)

Caption: General workflow for a chemical kinetics experiment.

Conclusion

While direct experimental kinetic data for **3-propoxyprop-1-yne** remains to be extensively published, a strong predictive framework can be established based on the principles of physical organic chemistry and the known reactivity of related compounds. The presence of the propoxy group is anticipated to have a discernible influence on reaction rates, particularly in reactions sensitive to electronic effects at the terminal alkyne. The provided experimental protocols offer a robust starting point for researchers to quantitatively investigate these predictions and further elucidate the chemical behavior of this versatile building block. Such studies are essential for the rational design of synthetic routes and the development of new chemical entities in the pharmaceutical and materials science industries.

References

- Diels, O., & Alder, K. (1928). Synthesen in der hydroaromatischen Reihe. Justus Liebigs Annalen der Chemie, 460(1), 98-122. [[Link](#)]
- Pandey, A. R., et al. (2023). A review towards synthesis of heterocycles using propargyl alcohols and propargyl amines. Monatshefte für Chemie - Chemical Monthly. [[Link](#)]
- Recent Advances in the Synthesis of Propargyl Derivatives, and Their Application as Synthetic Intermediates and Building Blocks. (2023). Molecules. [[Link](#)]
- Bovonsombat, P., & Sophanpanichkul, P. (2022). Electrophilic halogenations of propargyl alcohols: paths to α -haloenones, β -haloenones and mixed β,β -dihaloenones. RSC Advances. [[Link](#)]
- Diels-Alder reaction. In Wikipedia. [[Link](#)]
- O'Hair, R. A. J. (2006). Reaction kinetics by mass spectrometry (in the gas phase and in solution). Chemical Communications. [[Link](#)]
- Insights into Sonogashira Cross-Coupling by High-Throughput Kinetics and Descriptor Modeling. (2020). Organic Process Research & Development. [[Link](#)]
- Ashenhurst, J. (2013). Hydration and Oxymercuration of Alkynes. Master Organic Chemistry. [[Link](#)]
- Monitoring Kinetics by NMR. (2022). University of Wisconsin-Madison. [[Link](#)]

- Competition Studies in Alkyne Electrophilic Cyclization Reactions. (2009). *Molecules*. [\[Link\]](#)
- Reactions of Alkynes - Addition of HX and X₂. (2024). *Chemistry LibreTexts*. [\[Link\]](#)
- Hydration of Alkynes. (2024). *Chemistry LibreTexts*. [\[Link\]](#)
- Regiochemical variation in the electrophilic addition of HBr to 1-phenylprop-1-yne. (2003). *Organic & Biomolecular Chemistry*. [\[Link\]](#)
- Reaction Monitoring & Kinetics. Iowa State University. [\[Link\]](#)
- Recent Advances in the Synthesis of Propargyl Derivatives, and Their Application as Synthetic Intermediates and Building Blocks. (2023). *Semantic Scholar*. [\[Link\]](#)
- Gas Chromatography - Mass Spectrometry. University of Texas at Austin. [\[Link\]](#)
- In situ IR reaction kinetic profiles. *ResearchGate*. [\[Link\]](#)
- Scheme 6 Comparison of the two terminal alkyne cyclotrimerisation... *ResearchGate*. [\[Link\]](#)
- Improved Procedures for the Palladium-Catalyzed Coupling of Terminal Alkynes with Aryl Bromides (Sonogashira Coupling). (2003). *The Journal of Organic Chemistry*. [\[Link\]](#)
- Recent Advances in the Synthesis of Propargyl Derivatives, and Their Application as Synthetic Intermediates and Building Blocks. (2023). *MDPI*. [\[Link\]](#)
- Competition Studies in Alkyne Electrophilic Cyclization Reactions. (2009). *ResearchGate*. [\[Link\]](#)
- Sonogashira Coupling. *Organic Chemistry Portal*. [\[Link\]](#)
- Terminal and Internal Alkyne Complexes and Azide-Alkyne Cycloaddition Chemistry of Copper(I) Supported by a Fluorinated Bis(pyrazolyl)borate. (2013). *Inorganica Chimica Acta*. [\[Link\]](#)
- Synthesis of glycidyl propargyl ether. (2008). *Russian Journal of General Chemistry*. [\[Link\]](#)
- Acid Catalyzed Hydration of Alkynes with Practice Problems. *Chemistry Steps*. [\[Link\]](#)

- Kinetics / reaction monitoring. Northwestern University. [\[Link\]](#)
- The Role of In Situ/Operando IR Spectroscopy in Unraveling Adsorbate-Induced Structural Changes in Heterogeneous Catalysis. (2021). Chemical Reviews. [\[Link\]](#)
- Hydration of Alkynes. OpenStax. [\[Link\]](#)
- Alkyne Reactivity. Michigan State University. [\[Link\]](#)
- Methods for studying reaction kinetics in gas chromatography, exemplified by using the 1-chloro-2,2-dimethylaziridine interconversion reaction. (2019). Journal of Chromatography A. [\[Link\]](#)
- Rate Determination of Azide Click Reactions onto Alkyne Polymer Brush Scaffolds: A Comparison of Conventional and Catalyst-Free Cycloadditions for Tunable Surface Modification. (2012). Langmuir. [\[Link\]](#)
- Kinetic Profiling by NMR. University of St Andrews. [\[Link\]](#)
- Synthesis of Alkynyl Ketones by Sonogashira Cross-Coupling of Acyl Chlorides with Terminal Alkynes Mediated by Palladium Catalysts Deposited over Donor-Functionalized Silica Gel. (2020). Catalysts. [\[Link\]](#)
- Reactions of Alkynes. (2014). Master Organic Chemistry. [\[Link\]](#)
- Real-Time Gas Analysis and Reaction Monitoring using Mass Spectrometry. (2017). Hiden Analytical. [\[Link\]](#)
- Kinetic NMR Experiments. University of Maryland. [\[Link\]](#)
- Lec15 - IR Spectra of Alkynes and Nitriles. (2021). YouTube. [\[Link\]](#)
- Hydration of Alkynes. Organic Chemistry Tutor. [\[Link\]](#)
- Nickel Catalyzed Cycloaddition Reactions: Alkyne Cyclotrimerizations and Reductive Vinylidene Transfer Reactions. (2021). Purdue University Graduate School. [\[Link\]](#)

- Reaction Environment Design for Multigram Synthesis via Sonogashira Coupling over Heterogeneous Palladium Single-Atom Catalysts. (2023). ACS Sustainable Chemistry & Engineering. [[Link](#)]
- Application of in situ ATR-IR spectroscopy for the synthesis of bisphenol F: optimization, mechanistic and kinetics studies. (2021). Analytical Methods. [[Link](#)]
- An Introduction to Gas Chromatography Mass Spectrometry. University of Bristol. [[Link](#)]
- Photocatalytic Semi-Hydrogenation of Alkynes: A Game of Kinetics, Selectivity and Critical Timing. (2022). Catalysts. [[Link](#)]

Need Custom Synthesis?

BenchChem offers custom synthesis for rare earth carbides and specific isotopic labeling.

Email: info@benchchem.com or [Request Quote Online](#).

Sources

- 1. pdfs.semanticscholar.org [pdfs.semanticscholar.org]
- 2. Recent Advances in the Synthesis of Propargyl Derivatives, and Their Application as Synthetic Intermediates and Building Blocks - PMC [[pmc.ncbi.nlm.nih.gov](https://pubmed.ncbi.nlm.nih.gov/)]
- 3. [researchgate.net](https://www.researchgate.net) [[researchgate.net](https://www.researchgate.net)]
- 4. chem.libretexts.org [chem.libretexts.org]
- 5. arodes.hes-so.ch [arodes.hes-so.ch]
- 6. Terminal and Internal Alkyne Complexes and Azide-Alkyne Cycloaddition Chemistry of Copper(I) Supported by a Fluorinated Bis(pyrazolyl)borate - PMC [[pmc.ncbi.nlm.nih.gov](https://pubmed.ncbi.nlm.nih.gov/)]
- 7. 9.4 Hydration of Alkynes – Organic Chemistry: A Tenth Edition – OpenStax adaptation 1 [[ncstate.pressbooks.pub](https://openstax.org/r/ncstate-pressbooks-pub)]
- 8. Diels–Alder reaction - Wikipedia [en.wikipedia.org]
- 9. Reaction Monitoring & Kinetics | Chemical Instrumentation Facility [cif.iastate.edu]
- 10. www2.chem.wisc.edu [www2.chem.wisc.edu]
- 11. imserc.northwestern.edu [imserc.northwestern.edu]

- [12. Application of in situ ATR-IR spectroscopy for the synthesis of bisphenol F: optimization, mechanistic and kinetics studies - Analytical Methods \(RSC Publishing\) \[pubs.rsc.org\]](#)
- [13. researchgate.net \[researchgate.net\]](#)
- [14. m.youtube.com \[m.youtube.com\]](#)
- [15. etamu.edu \[etamu.edu\]](#)
- [16. Real-Time Gas Analysis and Reaction Monitoring using Mass Spectrometry \[hidenanalytical.com\]](#)
- To cite this document: BenchChem. [A Comparative Guide to the Reaction Kinetics of 3-Propoxyprop-1-yne]. BenchChem, [2026]. [Online PDF]. Available at: [\[https://www.benchchem.com/product/b13944666#kinetic-studies-of-3-propoxyprop-1-yne-reactions\]](https://www.benchchem.com/product/b13944666#kinetic-studies-of-3-propoxyprop-1-yne-reactions)

Disclaimer & Data Validity:

The information provided in this document is for Research Use Only (RUO) and is strictly not intended for diagnostic or therapeutic procedures. While BenchChem strives to provide accurate protocols, we make no warranties, express or implied, regarding the fitness of this product for every specific experimental setup.

Technical Support: The protocols provided are for reference purposes. Unsure if this reagent suits your experiment? [[Contact our Ph.D. Support Team for a compatibility check](#)]

Need Industrial/Bulk Grade? [Request Custom Synthesis Quote](#)

BenchChem

Our mission is to be the trusted global source of essential and advanced chemicals, empowering scientists and researchers to drive progress in science and industry.

Contact

Address: 3281 E Guasti Rd
Ontario, CA 91761, United States
Phone: (601) 213-4426
Email: info@benchchem.com