

Technical Support Center: Oxetane Ring Closure Optimization

Author: BenchChem Technical Support Team. **Date:** April 2026

Compound of Interest

Compound Name: 3-(Benzyloxy)oxetane

Cat. No.: B13940963

[Get Quote](#)

Executive Summary

Oxetanes are critical bioisosteres for gem-dimethyl and carbonyl groups, offering improved metabolic stability and solubility.^[1] However, the high ring strain (~106 kJ/mol) makes their synthesis thermodynamically challenging. This guide addresses the three dominant synthetic methodologies: Sulfoxonium Ylide Ring Expansion, Intramolecular Williamson Etherification, and the Paternò-Büchi Reaction.

Module 1: Sulfoxonium Ylide Ring Expansion (Epoxide to Oxetane)

The modern "Gold Standard" for modular synthesis.

Methodology Overview

This method utilizes dimethylsulfoxonium methylide (generated from TMSOI) to homologate epoxides. It is generally preferred over direct cyclization for sensitive substrates because it proceeds under thermodynamic control.

Experimental Protocol (Standard)

- Reagents: Trimethylsulfoxonium iodide (TMSOI) (1.2–1.5 equiv), Potassium tert-butoxide (KOtBu) (1.2–1.5 equiv).
- Solvent:t-BuOH:DMSO (1:1 to 10:1 ratio). Note: DMSO is essential for ylide solubility.
- Temperature: 50 °C – 70 °C.
- Procedure: Premix TMSOI and Base to form the ylide (clear solution) before adding the epoxide.

Troubleshooting & FAQs

Q: The reaction stalls at the intermediate alcohol (betaine) stage. Why? A: The ring closure of the alkoxide intermediate is the rate-determining step.

- Root Cause: The betaine intermediate is stable due to chelation or insufficient thermal energy to overcome the ring-strain barrier.
- Solution: Increase the reaction temperature to 80 °C. If using NaH/DMSO, switch to KOtBu/t-BuOH. The potassium cation coordinates less tightly to the alkoxide than sodium, making the oxygen more nucleophilic for the displacement of DMSO.

Q: I am observing a homoallylic alcohol instead of the oxetane. A: This is a "Cobalt Effect" warning.

- Root Cause: Trace Cobalt (Co) contamination (often from stir bars previously used in cross-couplings) catalyzes a hydride shift/elimination pathway instead of ring closure.
- Solution: Use brand new, metal-free stir bars. Wash all glassware with aqua regia if Co-catalysis was performed recently in the same vessel.

Q: My yield is low due to hydrolysis. A: Sulfoxonium ylides are water-sensitive.

- Solution: Ensure DMSO is anhydrous. Run the reaction under Argon.

Visualization: Mechanism & Troubleshooting Flow

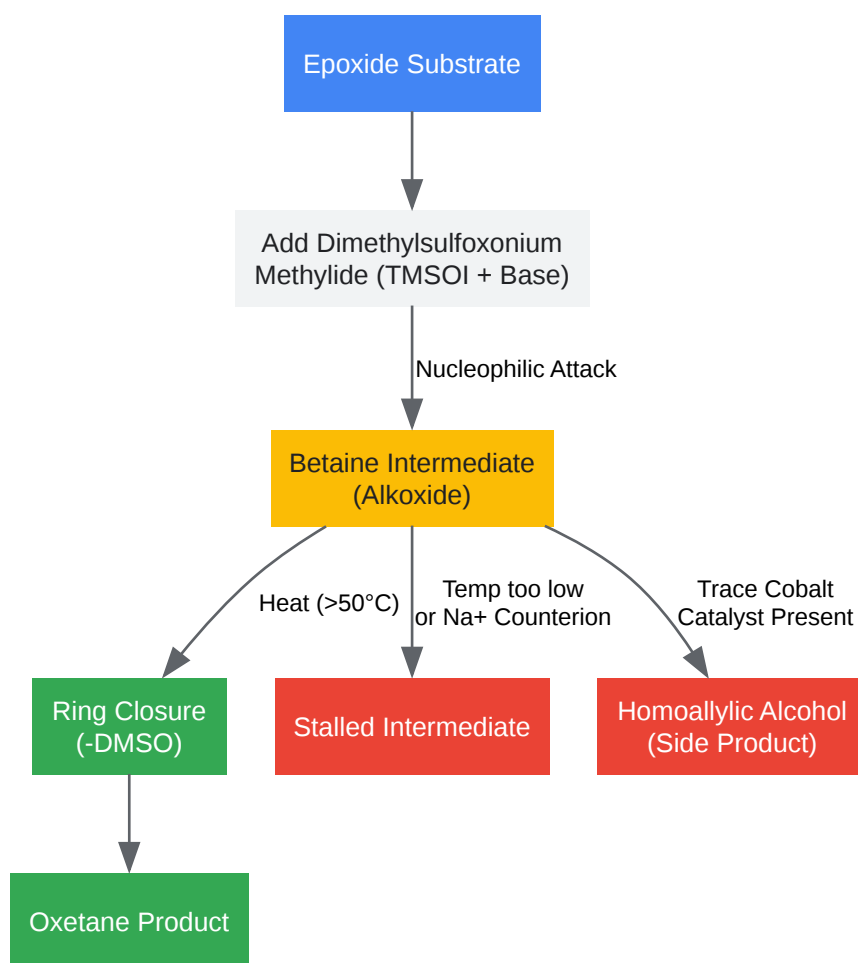

[Click to download full resolution via product page](#)

Figure 1: Decision flow for optimizing Sulfoxonium Ylide Ring Expansion.

Module 2: Intramolecular Williamson Etherification

Best for: 1,3-Diol precursors or chiral pool synthesis.

The Core Challenge: Grob Fragmentation

The primary failure mode in 1,3-cyclization is Grob Fragmentation (elimination), where the base triggers a cascade that breaks the carbon chain instead of closing the ring.

Optimization Table: Cyclization vs. Elimination

| Variable | Recommendation for Oxetane | Rationale |
|--------------------|--------------------------------|--|
| Leaving Group (LG) | Nosylate (Ns) or Triflate (Tf) | Faster displacement rates at lower temperatures compete favorably against elimination. Tosylates often require heat, promoting elimination. |
| Base | n-BuLi or NaH | Kinetic deprotonation is preferred. Avoid bulky bases like KOtBu which act as bases rather than nucleophiles, promoting E2-type elimination. |
| Solvent | THF (0 °C) | Polar aprotic solvents like DMF can stabilize the transition state for elimination in some substrates. |
| Substrate Geometry | Thorpe-Ingold Effect | Substrates with gem-dimethyl substitution at the C2 position cyclize significantly faster due to favorable conformational bias. |

Troubleshooting & FAQs

Q: I am getting an allylic alcohol and a carbonyl compound. A: This is classic Grob Fragmentation.

- Diagnostic: Check your NMR.^[2] Do you see terminal alkene protons?
- Fix: Switch the leaving group to Triflate (Tf). Perform the reaction at -78 °C to 0 °C using n-BuLi. The lower temperature suppresses the fragmentation pathway, which has a higher activation energy than the intramolecular S_N2.

Q: The reaction is incomplete even with excess base. A: The alkoxide might be forming a tight ion pair.

- Fix: Add 18-crown-6 (if using K⁺) or 15-crown-5 (if using Na⁺) to sequester the cation and increase the "naked" nucleophilicity of the oxygen.

Module 3: Paternò-Büchi Reaction ([2+2] Photocycloaddition)

Best for: Highly substituted oxetanes and spirocycles.

Critical Parameter: Wavelength & Source

Unlike thermal reactions, Paternò-Büchi is governed by excited state dynamics ($n \rightarrow \pi^*$ vs $\pi \rightarrow \pi^*$).

Experimental Protocol (Modern)

- Light Source: UV LED (365 nm) is preferred over medium-pressure mercury lamps for better selectivity.
- Concentration: High concentration (0.5 M – 1.0 M) favors intermolecular cycloaddition over competitive solvent quenching.
- Stoichiometry: Use the alkene in excess (3–5 equiv) if the carbonyl is the valuable component.

Troubleshooting & FAQs

Q: I am getting a mixture of regioisomers (Head-to-Head vs. Head-to-Tail). A: Regioselectivity is dictated by the stability of the 1,4-diradical intermediate.

- Theory: The reaction proceeds through the most stable diradical.
- Fix: Modifying the electronics of the alkene is the only robust way to flip selectivity. Electron-rich alkenes (enol ethers) generally give high selectivity. Steric bulk on the alkene can also force a specific orientation.

Q: My product degrades during irradiation. A: "Over-irradiation" leads to secondary photolysis of the oxetane ring.

- Fix: Monitor reaction by GC-MS/LC-MS. Stop at 80-90% conversion. Do not aim for 100%.

Module 4: Isolation & Purification (Critical)

Oxetanes are acid-sensitive and can open on silica gel.

Standard Operating Procedure (SOP) for Purification

- Quench: Do not use strong acids (HCl). Quench with saturated NH₄Cl or water.[3]
- Silica Pre-treatment: Flush the silica column with 1% Triethylamine (Et₃N) in Hexanes before loading the sample.
- Eluent: Maintain 0.5% – 1% Et₃N in the mobile phase during chromatography.
- Alternative: Use neutral alumina if the substrate is extremely acid-sensitive.

Visualization: Method Selection Matrix

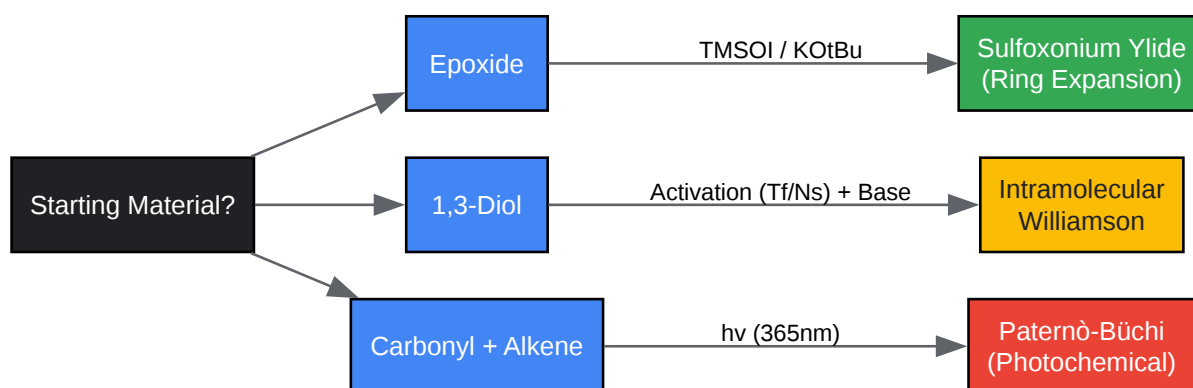

[Click to download full resolution via product page](#)

Figure 2: Strategic selection of synthetic route based on available precursors.

References

- Bull, J. A., et al. (2016).[4] Oxetanes: Recent Advances in Synthesis, Reactivity, and Medicinal Chemistry. Chemical Reviews. [Link](#)
 - Authoritative review on oxetane synthesis and properties.

- Wuitschik, G., Carreira, E. M., et al. (2010). Oxetanes in Drug Discovery: Structural and Synthetic Insights. *Journal of Medicinal Chemistry*. [Link](#)
 - Seminal paper on the "Bull-James" type ring expansion and bioisostere properties.
- Bach, T. (1998). Stereoselective Intermolecular [2 + 2]-Photocycloaddition Reactions and Their Application in Synthesis. *Synthesis*. [Link](#)
 - Foundational text on P
- Aitken, D. J., et al. (2014). Grob Fragmentation vs. Oxetane Formation: A Computational Study. *Journal of Organic Chemistry*. [Link](#)
 - Mechanistic grounding for the elimination vs.
- Corey, E. J., & Chaykovsky, M. (1965). Dimethyloxosulfonium Methylide and Dimethylsulfonium Methylide.[5] Formation and Application to Organic Synthesis. *Journal of the American Chemical Society*. [2] [Link](#)
 - Original description of the ylide chemistry adapted for oxetanes.

Need Custom Synthesis?

BenchChem offers custom synthesis for rare earth carbides and specific isotopic labeling.

Email: info@benchchem.com or [Request Quote Online](#).

Sources

- 1. pdf.benchchem.com [pdf.benchchem.com]
- 2. denmarkgroup.web.illinois.edu [denmarkgroup.web.illinois.edu]
- 3. pdf.benchchem.com [pdf.benchchem.com]
- 4. pubs.acs.org [pubs.acs.org]
- 5. [Corey-Chaykovsky Reaction](https://organic-chemistry.org) [organic-chemistry.org]
- To cite this document: BenchChem. [Technical Support Center: Oxetane Ring Closure Optimization]. BenchChem, [2026]. [Online PDF]. Available at:

[<https://www.benchchem.com/product/b13940963/docs#technical-support-center-oxetane-ring-closure-optimization>]

Disclaimer & Data Validity:

The information provided in this document is for Research Use Only (RUO) and is strictly not intended for diagnostic or therapeutic procedures. While BenchChem strives to provide accurate protocols, we make no warranties, express or implied, regarding the fitness of this product for every specific experimental setup.

Technical Support: The protocols provided are for reference purposes. Unsure if this reagent suits your experiment?

Need Industrial/Bulk Grade? [Request Custom Synthesis Quote](#)

BenchChem

Our mission is to be the trusted global source of essential and advanced chemicals, empowering scientists and researchers to drive progress in science and industry.

Contact

Address: 3281 E Guasti Rd
Ontario, CA 91761, United States
Phone: (601) 213-4426
Email: info@benchchem.com

[Contact our Ph.D. Support Team for a compatibility check](#)