

# Reaction Kinetics and Synthetic Strategies for Chroman-3-carbaldehyde: A Comparative Guide

**Author:** BenchChem Technical Support Team. **Date:** April 2026

## Compound of Interest

Compound Name: *Chroman-3-carbaldehyde*

CAS No.: *944903-95-1*

Cat. No.: *B1394481*

[Get Quote](#)

The chroman (benzopyran) scaffold is a privileged structural motif in medicinal chemistry, frequently found in natural products, antioxidants, and pharmaceutical agents targeting neurodegenerative and cardiovascular diseases. Among its derivatives, **Chroman-3-carbaldehyde** serves as a highly versatile synthetic intermediate. Its formyl group provides a reactive handle for reductive aminations, Wittig reactions, and further oxidations, making it indispensable for drug discovery pipelines[1].

However, the synthesis of highly functionalized, enantiopure **chroman-3-carbaldehydes** presents significant kinetic and thermodynamic challenges. Traditional step-wise syntheses often suffer from poor atom economy and low stereocontrol. In recent years, cascade reactions—specifically oxa-Michael/aldol and oxa-Michael/Michael cascades—have revolutionized this space.

This guide objectively compares three distinct synthetic methodologies for producing **chroman-3-carbaldehyde** derivatives, analyzing their reaction kinetics, catalytic mechanisms, and practical scalability to assist researchers in selecting the optimal route for their specific applications.

## Comparative Analysis of Synthetic Methodologies

### Method A: Traditional Base-Catalyzed Cascade (Achiral)

The classical approach to synthesizing the chroman core involves a base-catalyzed (e.g., DBU or  $\text{NaOH}$ ) condensation between a 2-hydroxybenzaldehyde derivative and an

unsaturated aldehyde (like acrolein or crotonaldehyde).

- **Kinetics & Mechanism:** The reaction proceeds via an initial oxa-Michael addition of the phenoxide to the  $\beta$ -carbon of the unsaturated aldehyde, followed by an intramolecular aldol condensation. Kinetically, this is a fast process due to the high nucleophilicity of the phenoxide ion.
- **Limitations:** This method is entirely achiral. While it rapidly builds the chroman skeleton, it lacks the stereocontrol required for modern drug development, yielding racemic mixtures that require costly downstream chiral resolution.

### Method B: Homogeneous Organocatalytic Cascade (Asymmetric)

To address the stereochemical limitations of base catalysis, asymmetric organocatalysis utilizing chiral secondary amines (such as diphenylprolinol silyl ethers) has been developed [2] [3].

- **Kinetics & Mechanism:** This method relies on a dual-activation cycle. The chiral amine condenses with the  $\beta$ -unsaturated aldehyde to form an iminium ion, significantly lowering the LUMO and facilitating a highly enantioselective oxa-Michael addition by the phenol. Subsequent tautomerization yields an enamine intermediate (raising the HOMO), which drives the intramolecular aldol ring closure.
- **Performance:** While the reaction kinetics are slower than traditional base catalysis (often requiring 24–72 hours at room temperature to achieve high conversion), the enantiomeric excess (ee) routinely exceeds 95%.

## Method C: Heterogeneous Synergistic Catalysis (Advanced)

A major bottleneck of homogeneous organocatalysis is catalyst recovery. Recent advancements have introduced heterogeneous acid-base synergic catalysts, such as chiral amines grafted onto mesoporous silica (e.g., SBA-15)[4][5][6].

- **Kinetics & Mechanism:** In this system, the immobilized chiral amine acts as the basic site, while the inherent surface silanol ( ) groups of the silica act as acidic hydrogen-bond donors. This dual-activation stabilizes the transition state, accelerating the oxa-Michael/Michael cascade.
- **Performance:** This method not only matches the stereoselectivity of homogeneous systems but also significantly improves the Turnover Frequency (TOF). Furthermore, it enables continuous-flow synthesis, drastically reducing reaction times from days to minutes. Recent innovations have even utilized core-shell-structured thermoresponsive hydrogels to harmonize incompatible aqueous cascade processes[7][8][9].

## Kinetic & Performance Data Comparison

The following table summarizes the experimental kinetic data and performance metrics of the three methodologies based on standardized cascade reactions yielding **chroman-3-carbaldehyde** derivatives.

Parameter	Method A: Achiral Base Catalysis	Method B: Homogeneous Organocatalysis	Method C: Heterogeneous Silica-Grafted
Catalyst	or DBU (10-20 mol%)	Diphenylprolinol silyl ether (10-20 mol%)	SBA-15-grafted chiral amine (5-10 mol%)
Reaction Time	2 – 6 hours	24 – 72 hours	12 – 24 h (Batch) / <1 h (Flow)
Temperature	60°C – 80°C	0°C – 25°C	25°C – 40°C
Yield (%)	75 – 85%	80 – 95%	85 – 98%
Enantiomeric Excess (ee)	Racemic (0%)	90 – 99%	92 – 97%
Turnover Number (TON)	~5	~5 - 10	> 50 (Recyclable up to 5 times)
Scalability	High (Batch)	Moderate (Cost of catalyst)	High (Continuous Flow compatible)

## Mechanistic Visualizations

### The Organocatalytic Activation Cycle

The following diagram illustrates the causality behind the high stereocontrol observed in Method B. The steric bulk of the chiral catalyst shields one face of the iminium intermediate, dictating the stereochemistry of the initial oxa-Michael addition.



[Click to download full resolution via product page](#)

Fig 1: Iminium-enamine activation cycle for asymmetric **chroman-3-carbaldehyde** synthesis.

## Heterogeneous Continuous Flow Setup

For Method C, transitioning from batch to continuous flow enhances mass transfer and kinetic throughput.

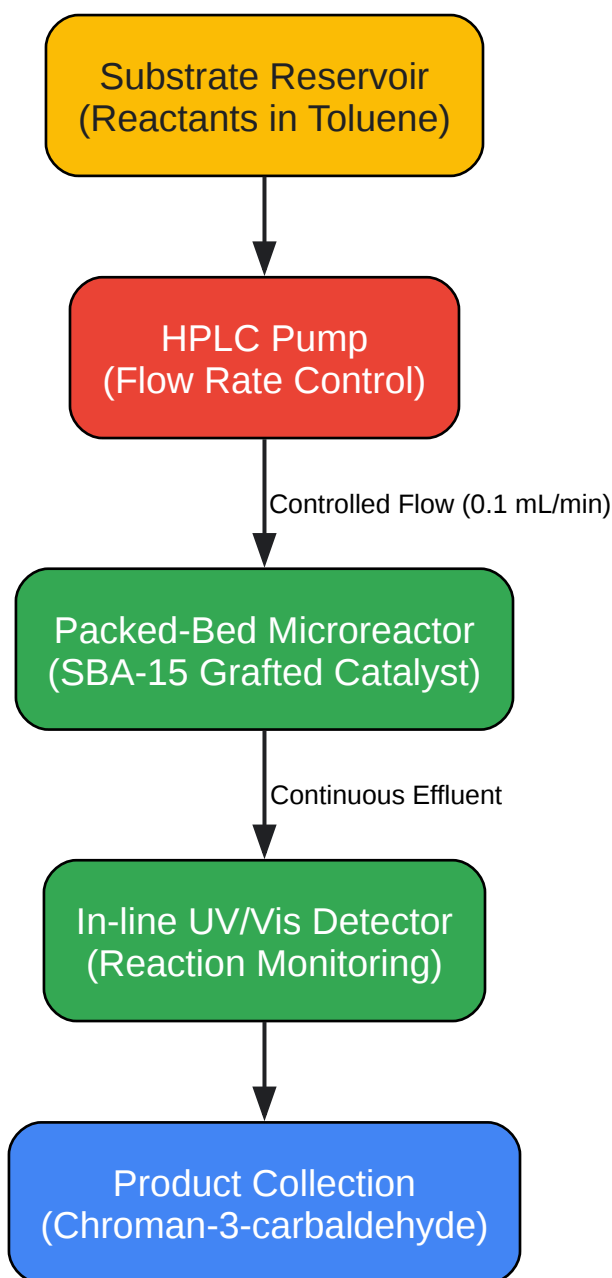

[Click to download full resolution via product page](#)

Fig 2: Continuous flow microreactor setup utilizing heterogeneous silica-grafted catalysts.

## Experimental Protocols

To ensure reproducibility and self-validation, the following step-by-step protocols detail the execution of the asymmetric homogeneous and heterogeneous methodologies.

## Protocol 1: Homogeneous Asymmetric Synthesis (Batch)

Objective: Synthesis of chiral **chroman-3-carbaldehyde** via diphenylprolinol silyl ether catalysis[2][3].

- **Reaction Setup:** In a flame-dried 10 mL round-bottom flask equipped with a magnetic stir bar, dissolve 2-hydroxybenzaldehyde (1.0 mmol) and the -unsaturated aldehyde (1.2 mmol) in anhydrous toluene (2.0 mL).
- **Catalyst Addition:** Add (S)-diphenylprolinol trimethylsilyl ether (0.1 mmol, 10 mol%) and a catalytic amount of benzoic acid (0.1 mmol, 10 mol%) to facilitate enamine hydrolysis.
- **Kinetic Monitoring:** Stir the mixture at room temperature (25°C). Monitor the reaction progress via Thin Layer Chromatography (TLC) using a hexane/ethyl acetate (4:1) eluent system. The reaction typically reaches completion within 48 hours.
- **Quenching & Extraction:** Quench the reaction with saturated aqueous (5 mL). Extract the aqueous layer with dichloromethane ( mL). Combine the organic layers, dry over anhydrous , and concentrate under reduced pressure.
- **Validation:** Purify the crude product via silica gel flash chromatography. Determine the conversion and yield via NMR analysis (using dimethyl maleate as an internal standard). Determine the enantiomeric excess (ee) using chiral High-Performance Liquid Chromatography (HPLC) with a Chiralpak OD-H column[10].

## Protocol 2: Heterogeneous Synthesis (Continuous Flow)

Objective: High-throughput synthesis using SBA-15 grafted chiral amines[4][5][6].

- **Reactor Preparation:** Pack a stainless-steel microreactor column (4.6 mm internal diameter 50 mm length) with the SBA-15-supported chiral amine catalyst (approx. 300 mg). Wash the column with anhydrous toluene at a flow rate of 0.5 mL/min for 30 minutes to equilibrate the bed.
- **Substrate Preparation:** Prepare a stock solution containing 2-hydroxybenzaldehyde (0.5 M) and the -unsaturated aldehyde (0.6 M) in anhydrous toluene.
- **Flow Execution:** Connect the substrate reservoir to an HPLC pump. Pump the solution through the packed-bed microreactor at a precisely controlled flow rate of 0.1 mL/min at 40°C.
- **Collection & Analysis:** Collect the effluent in a receiving flask. The residence time in the reactor is approximately 15 minutes. Analyze the steady-state effluent via in-line UV/Vis detection and offline chiral HPLC to confirm yield and ee.
- **Catalyst Regeneration:** Once conversion drops below 90%, flush the reactor with a 1% solution of acetic acid in methanol, followed by pure toluene, to regenerate the basic sites of the immobilized catalyst.

## Conclusion

The synthesis of **chroman-3-carbaldehyde** has evolved from rudimentary base-catalyzed condensations to highly sophisticated, stereocontrolled cascade reactions. While homogeneous organocatalysis (Method B) provides excellent enantioselectivity, the shift towards heterogeneous, silica-grafted catalysts (Method C) represents the future of scalable pharmaceutical manufacturing. By leveraging acid-base synergistic effects and continuous flow technologies, researchers can achieve superior turnover frequencies, eliminate tedious catalyst separation steps, and maintain the rigorous stereochemical purity required for modern drug development.

## References

- Zhang, J. M., et al. "Organocatalytic conjugate addition of nitroalkanes to 2H-chromene-3-carbaldehydes: synthesis of highly functionalized chroman derivatives." *Arkivoc*, 2009 (xiv) 362-375. URL: [\[Link\]](#)
- Wang, S., He, J., & An, Z. "Heterogeneous enantioselective synthesis of chromans via the oxa-Michael–Michael cascade reaction synergically catalyzed by grafted chiral bases and inherent hydroxyls on mesoporous silica surface." *Chemical Communications (RSC)*, 2017, 53, 8882. URL: [\[Link\]](#)
- Su, Y., et al. "Harmonization of an incompatible aqueous aldol condensation/oxa-Michael addition/reduction cascade process over a core–shell-structured thermoresponsive catalyst." *Green Chemistry (RSC)*, 2023, 25, 6859-6868. URL: [\[Link\]](#)

#### *Need Custom Synthesis?*

*BenchChem offers custom synthesis for rare earth carbides and specific isotopic labeling.*

*Email: [info@benchchem.com](mailto:info@benchchem.com) or [Request Quote Online](#).*

## Sources

- 1. [Chroman-3-ylmethanamine|10185-46-3|Research Chemical \[benchchem.com\]](#)
- 2. [arkat-usa.org \[arkat-usa.org\]](#)
- 3. [arkat-usa.org \[arkat-usa.org\]](#)
- 4. [Heterogeneous enantioselective synthesis of chromans via the oxa-Michael–Michael cascade reaction synergically catalyzed by grafted chiral bases and inherent hydroxyls on mesoporous silica surface - Chemical Communications \(RSC Publishing\) \[pubs.rsc.org\]](#)
- 5. [Heterogeneous enantioselective synthesis of chromans via the oxa-Michael–Michael cascade reaction synergically catalyzed by grafted chiral bases and inherent hydroxyls on mesoporous silica surface - Chemical Communications \(RSC Publishing\) \[pubs.rsc.org\]](#)
- 6. [Heterogeneous enantioselective synthesis of chromans via the oxa-Michael–Michael cascade reaction synergically catalyzed by grafted chiral bases and inherent hydroxyls on mesoporous silica surface - Chemical Communications \(RSC Publishing\) \[pubs.rsc.org\]](#)
- 7. [Harmonization of an incompatible aqueous aldol condensation/oxa-Michael addition/reduction cascade process over a core–shell-structured thermoresponsive catalyst - Green Chemistry \(RSC Publishing\) \[pubs.rsc.org\]](#)

- [8. Harmonization of an incompatible aqueous aldol condensation/oxa-Michael addition/reduction cascade process over a core–shell-structured thermoresponsive catalyst - Green Chemistry \(RSC Publishing\) \[pubs.rsc.org\]](#)
- [9. Harmonization of an incompatible aqueous aldol condensation/oxa-Michael addition/reduction cascade process over a core–shell-structured thermoresponsive catalyst - Green Chemistry \(RSC Publishing\) \[pubs.rsc.org\]](#)
- [10. researchgate.net \[researchgate.net\]](#)
- To cite this document: BenchChem. [Reaction Kinetics and Synthetic Strategies for Chroman-3-carbaldehyde: A Comparative Guide]. BenchChem, [2026]. [Online PDF]. Available at: [<https://www.benchchem.com/product/b1394481/docs#reaction-kinetics-and-synthetic-strategies-for-chroman-3-carbaldehyde-a-comparative-guide>]

---

### Disclaimer & Data Validity:

The information provided in this document is for Research Use Only (RUO) and is strictly not intended for diagnostic or therapeutic procedures. While BenchChem strives to provide accurate protocols, we make no warranties, express or implied, regarding the fitness of this product for every specific experimental setup.

**Technical Support:** The protocols provided are for reference purposes. Unsure if this reagent suits your experiment?

**Need Industrial/Bulk Grade?** [Request Custom Synthesis Quote](#)

## BenchChem

Our mission is to be the trusted global source of essential and advanced chemicals, empowering scientists and researchers to drive progress in science and industry.

### Contact

Address: 3281 E Guasti Rd

Ontario, CA 91761, United States

Phone: (601) 213-4426

Email: [info@benchchem.com](mailto:info@benchchem.com)

Contact our Ph.D. Support Team for a compatibility check