

# "environmental fate of N,N-Dioctylhexanamide"

**Author:** BenchChem Technical Support Team. **Date:** April 2026

## Compound of Interest

Compound Name: *N,N-Dioctylhexanamide*

CAS No.: 55334-54-8

Cat. No.: B13935190

[Get Quote](#)

An In-depth Technical Guide to the Environmental Fate of **N,N-Dioctylhexanamide**

## Abstract

**N,N-Dioctylhexanamide** (DOHA) is a tertiary amide whose environmental behavior is not extensively documented in public literature. This guide provides a comprehensive framework for assessing its environmental fate, designed for researchers, environmental scientists, and drug development professionals. By integrating established principles of environmental chemistry with predictive modeling and standardized testing protocols, this document outlines the likely pathways of DOHA's degradation, persistence, and distribution. We will explore its physicochemical properties, abiotic and biotic degradation mechanisms, potential for bioaccumulation, and the analytical methodologies required for its detection and quantification in environmental matrices. This guide emphasizes the causality behind experimental design, providing a robust, scientifically-grounded approach to characterizing the lifecycle of **N,N-Dioctylhexanamide** or structurally similar molecules in the environment.

## Introduction and Physicochemical Profile

**N,N-Dioctylhexanamide** (CAS: 55334-54-8) is a high-molecular-weight tertiary amide. Its structure consists of a hexanoyl group bonded to a nitrogen atom, which is, in turn, substituted

with two octyl chains.[1] While specific applications are not widely published, its structural similarity to other N,N-dialkyl amides suggests potential use as a solvent, extractant, or chemical intermediate. For instance, related compounds like **N,N-dioctylhexanamide** have been studied in the context of radiolytic stability, hinting at applications in fields such as nuclear fuel reprocessing.[2]

Understanding the environmental fate of any chemical begins with its fundamental physicochemical properties. These parameters govern its partitioning between air, water, soil, and biota, and its susceptibility to various degradation processes. For DOHA, many of these properties are not experimentally determined and must be estimated or identified as critical data gaps.

Property	Value / Predicted Behavior	Significance for Environmental Fate
Molecular Formula	<chem>C22H45NO</chem> [1]	Defines the elemental composition and basic structure.
Molecular Weight	339.60 g/mol [1]	Influences properties like volatility and diffusion rates.
Structure	Tertiary Amide	The amide bond is known for its high stability, particularly in tertiary amides which are resistant to hydrolysis.[3][4]
Water Solubility (logS)	Predicted to be very low	Low water solubility limits mobility in aquatic systems but increases partitioning to sediment and soil organic matter.[5]
Octanol-Water Partition Coefficient (log Kow)	Predicted to be high (>5)	A high log Kow suggests a strong tendency to partition from water into fatty tissues, indicating a potential for bioaccumulation.[6]
Vapor Pressure	Predicted to be very low	Low volatility means the compound is unlikely to be present in the atmosphere in significant concentrations.[7]
Henry's Law Constant	Predicted to be low	Indicates a low tendency to partition from water to air.[7]

## A Proposed Framework for Environmental Fate Assessment

Given the limited specific data for DOHA, a structured, tiered approach to its environmental risk assessment is necessary. This workflow ensures that fundamental properties are characterized first, which then informs the design of more complex degradation and bioaccumulation studies.

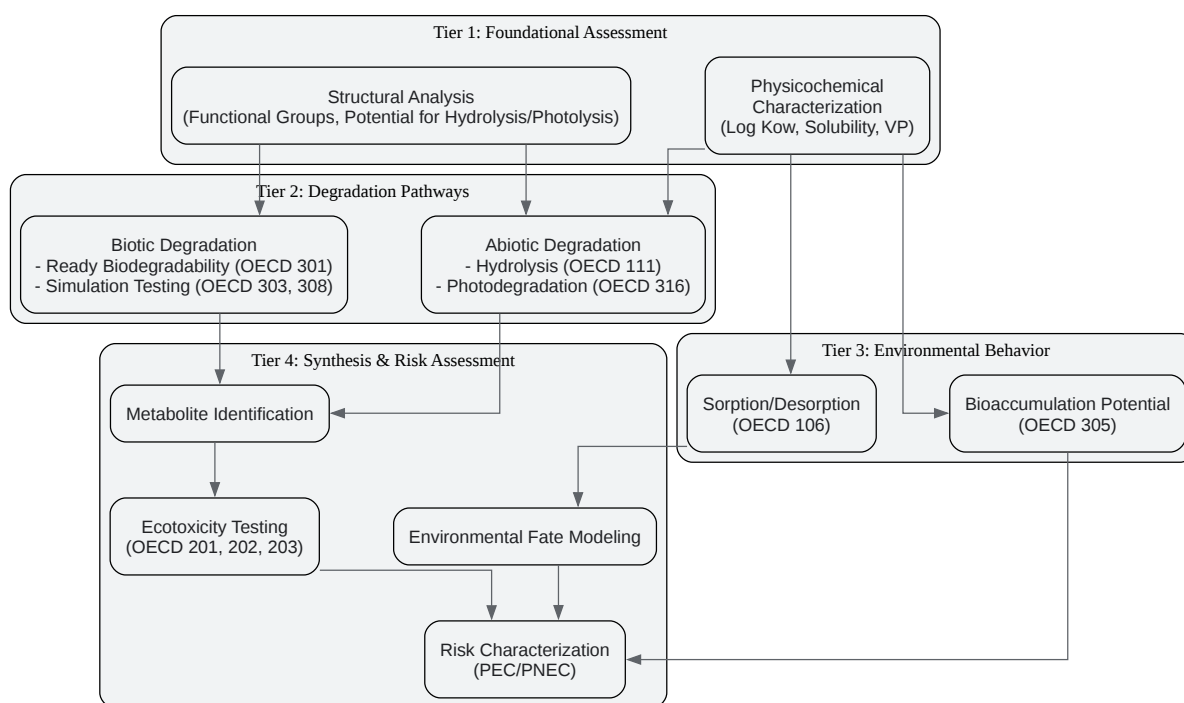

[Click to download full resolution via product page](#)

Caption: A tiered workflow for assessing the environmental fate of DOHA.

## Abiotic Degradation Pathways: Hydrolysis and Photodegradation

Abiotic processes are chemical reactions that occur in the environment without the involvement of microorganisms. For DOHA, the most relevant pathways are hydrolysis and photodegradation.

### Hydrolysis

Hydrolysis is the cleavage of a chemical bond by the addition of water. The amide bond in DOHA is the primary site for potential hydrolysis. However, amides are generally stable, and tertiary amides are exceptionally resistant to cleavage due to steric hindrance and the poor leaving group nature of the dialkylamine anion.[4][8] Vigorous conditions, such as concentrated acids or bases at high temperatures, are typically required for their hydrolysis, conditions not found in the natural environment.[3][9]

A study involving the structurally similar **N,N-dioctylhexanamide** in the context of nuclear waste processing showed it to be stable against hydrolysis by nitric acid, reinforcing the expectation of high stability.[2]

Experimental Protocol: Hydrolysis as a Function of pH (Adapted from OECD Guideline 111)

- Preparation: Prepare sterile aqueous buffer solutions at pH 4, 7, and 9.
- Dosing: Add a sterile solution of DOHA in a water-miscible, low-volatility solvent to each buffer solution to achieve a final concentration well below its water solubility limit. The solvent volume should not exceed 1% of the total volume.
- Incubation: Incubate the solutions in the dark at a constant temperature (e.g., 25°C).
- Sampling: At predetermined intervals, collect triplicate samples from each pH solution.
- Analysis: Immediately analyze the samples for the concentration of DOHA using a validated analytical method (e.g., LC-MS/MS).

- Data Evaluation: Plot the concentration of DOHA versus time for each pH. If degradation occurs, determine the rate constant and half-life.
  - Self-Validation: The protocol's integrity is maintained by using sterile conditions to prevent microbial degradation, dark incubation to prevent photodegradation, and buffered solutions to maintain constant pH.

## Photodegradation

Photodegradation involves the breakdown of molecules by light. This can occur through two primary mechanisms:

- Direct Photolysis: The chemical itself absorbs sunlight and undergoes a transformation. This requires the presence of a chromophore (a light-absorbing part of the molecule). DOHA's structure lacks significant chromophores that absorb light in the environmentally relevant spectrum (>290 nm).
- Indirect Photolysis: Other substances in the environment, known as photosensitizers (e.g., chromophoric dissolved organic matter (CDOM), nitrate ions), absorb sunlight and transfer the energy to the chemical, causing its degradation.<sup>[10]</sup> This is the more likely photodegradation pathway for DOHA in sunlit surface waters. Reactive species like hydroxyl radicals ( $\bullet\text{OH}$ ) and singlet oxygen generated by photosensitizers can react with the alkyl chains of DOHA.

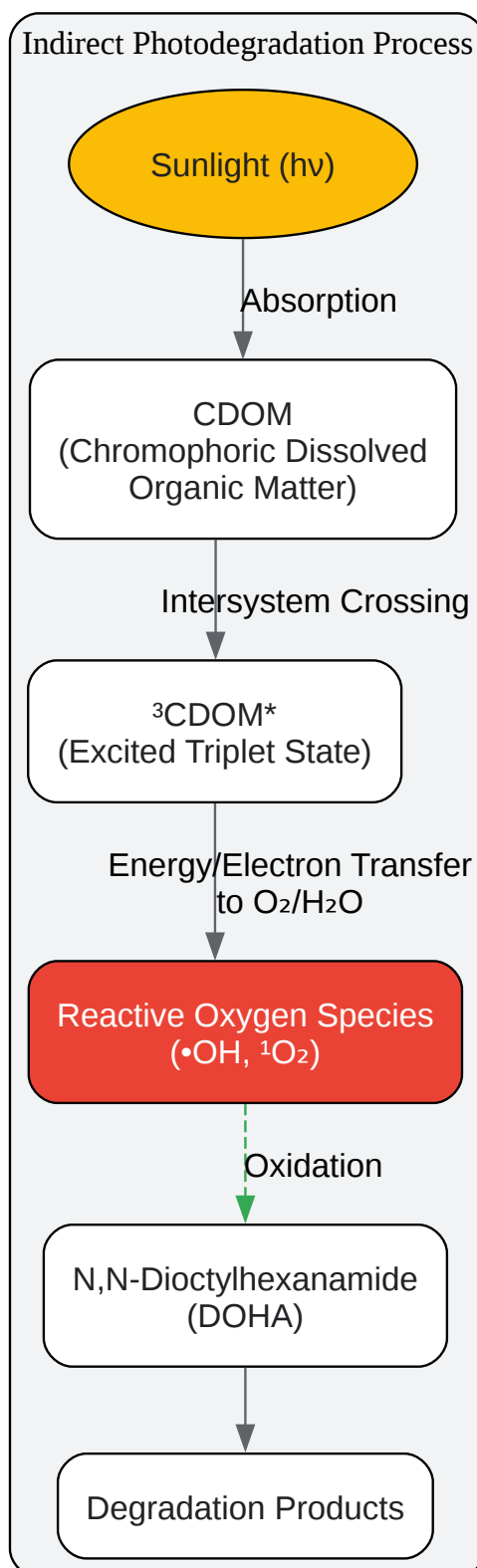

[Click to download full resolution via product page](#)

Caption: The mechanism of indirect photodegradation of DOHA in water.

## Biotic Degradation Pathway

Biodegradation is the breakdown of organic matter by microorganisms and is often the most significant removal mechanism for chemicals in the environment.[11] The susceptibility of DOHA to biodegradation will largely determine its environmental persistence.

Based on its structure, two primary metabolic pathways are plausible:

- **Oxidation of Alkyl Chains:** Microorganisms can initiate degradation of the long octyl chains via terminal or sub-terminal oxidation, similar to the metabolism of alkanes.[12]
- **Amide Hydrolysis:** Enzymatic hydrolysis via amidase enzymes could cleave the amide bond, yielding hexanoic acid and dioctylamine. While chemically difficult, enzymatic catalysis can overcome high activation energies.

Experimental Protocol: Ready Biodegradability – CO<sub>2</sub> Evolution Test (Adapted from OECD Guideline 301B)

- **Inoculum:** Collect activated sludge from a domestic wastewater treatment plant as the microbial source.
- **Test Setup:** Prepare multiple sealed vessels. Each contains a defined mineral medium, the microbial inoculum, and DOHA as the sole source of organic carbon.
- **Controls:**
  - **Blank Control:** Inoculum and mineral medium only (to measure background CO<sub>2</sub> evolution).
  - **Reference Control:** A readily biodegradable substance (e.g., sodium benzoate) to verify the viability of the inoculum.
  - **Toxicity Control:** DOHA plus the reference substance (to check if DOHA is toxic to the microorganisms).
- **Incubation:** Incubate the vessels in the dark at 20-25°C with continuous mixing for 28 days.

- Measurement: Periodically measure the amount of CO<sub>2</sub> evolved from each vessel. CO<sub>2</sub> can be trapped in a barium hydroxide or sodium hydroxide solution and quantified by titration.
- Data Evaluation: Calculate the percentage of theoretical CO<sub>2</sub> production (%ThCO<sub>2</sub>) for DOHA. If >60% ThCO<sub>2</sub> is produced within a 10-day window during the 28-day test, the substance is considered "readily biodegradable."
  - Self-Validation: The inclusion of blank, reference, and toxicity controls ensures that the observed degradation is due to microbial activity on the test substance and that the microbial community is healthy and not inhibited.

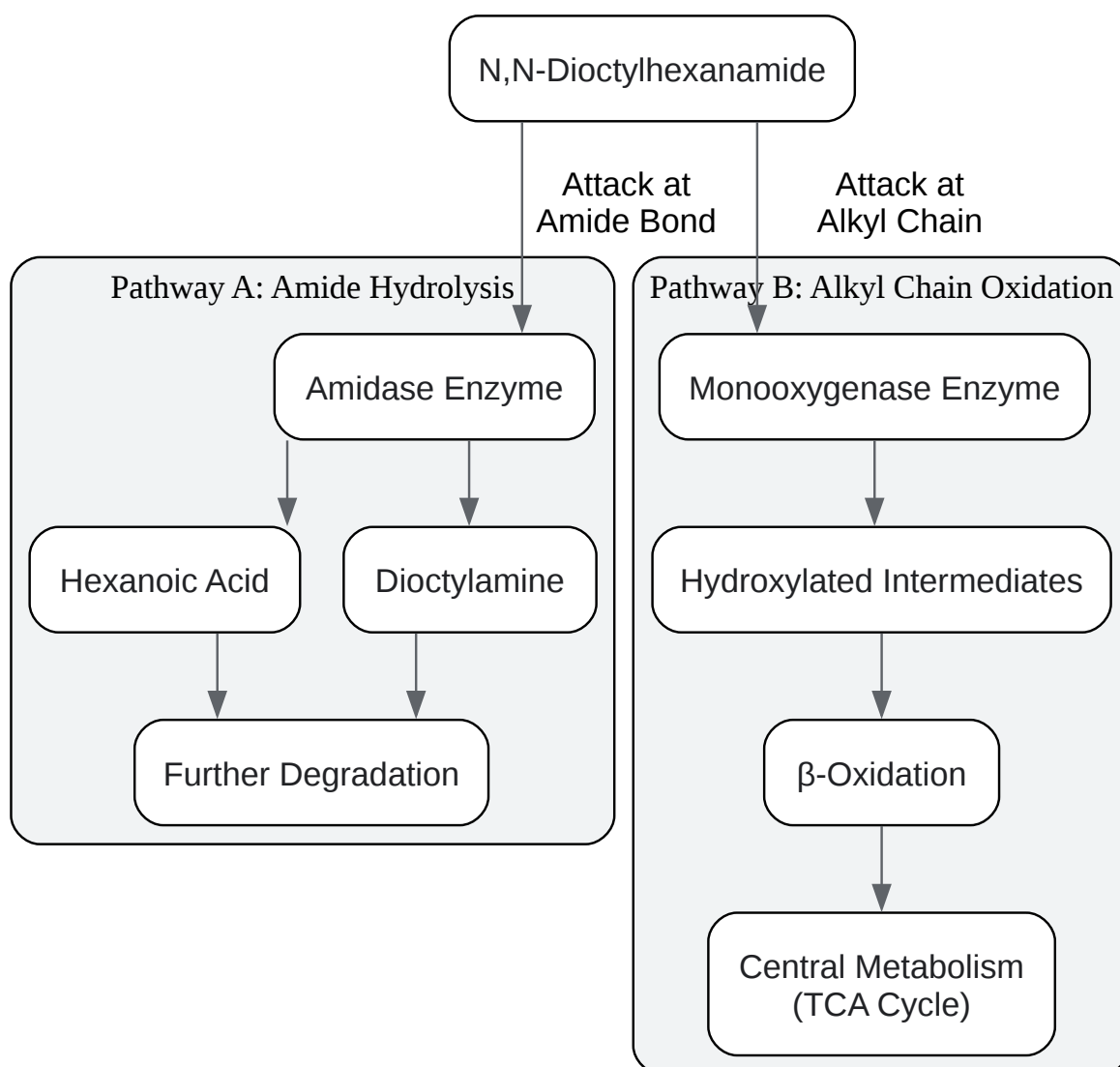

[Click to download full resolution via product page](#)

Caption: Plausible initial steps in the biodegradation of DOHA.

## Environmental Distribution and Bioaccumulation Mobility and Sorption

The high predicted log Kow and low water solubility of DOHA strongly suggest it will partition out of the water column and sorb to organic carbon in soil and sediment.[7][13] This reduces its bioavailability in the aqueous phase but can lead to its accumulation in solids, creating a long-term reservoir of contamination. Its mobility in soil and potential to leach into groundwater is expected to be very low.

### Bioaccumulation

Bioaccumulation is the net accumulation of a chemical in an organism from all exposure routes (water, food, air). For aquatic organisms, a key metric is the Bioconcentration Factor (BCF), which measures uptake from water alone.[6] Chemicals with a high log Kow (typically > 3) and resistance to metabolic breakdown are often bioaccumulative.[6] Given DOHA's predicted high lipophilicity and stability, its potential for bioaccumulation is a significant concern and requires experimental verification.

Experimental Protocol: Bioaccumulation in Fish (Adapted from OECD Guideline 305)

- Test Organism: Use a suitable fish species, such as rainbow trout or zebrafish.
- Acclimation: Acclimate fish to test conditions.
- Uptake Phase: Expose a group of fish to a constant, low concentration of DOHA in water for a period of time (e.g., 28 days). Maintain a control group in clean water.
- Sampling (Uptake): Periodically sample a subset of fish and the water to measure the concentrations of DOHA.
- Depuration Phase: After the uptake phase, transfer the remaining exposed fish to clean, flowing water.

- Sampling (Depuration): Sample the fish at intervals during the depuration phase to measure the rate at which DOHA is eliminated.
- Analysis: Analyze tissue and water samples using a validated analytical method.
- Calculation: Calculate the BCF as the ratio of the DOHA concentration in the fish (at steady-state) to the concentration in the water. Calculate the depuration rate constant.
  - Self-Validation: Maintaining constant exposure concentrations, using a flow-through system to prevent depletion of the test substance, and including a depuration phase provide a comprehensive and verifiable assessment of both uptake and elimination kinetics.

## Analytical Methodologies for Environmental Monitoring

Reliable assessment of environmental fate requires sensitive and selective analytical methods to detect DOHA and its potential transformation products at trace concentrations (ng/L to µg/L) in complex matrices.[\[14\]](#)[\[15\]](#)

A typical analytical workflow would involve:

- Sample Collection and Preservation.
- Extraction and Cleanup: Isolating the analyte from the matrix (water, soil, tissue) and removing interfering substances. Solid-Phase Extraction (SPE) is a common and effective technique for this purpose.[\[15\]](#)
- Instrumental Analysis: Quantifying the analyte. Given DOHA's molecular weight and expected properties, either Gas Chromatography-Mass Spectrometry (GC-MS) or Liquid Chromatography-Tandem Mass Spectrometry (LC-MS/MS) would be suitable.[\[16\]](#)[\[17\]](#) LC-MS/MS is often preferred for its high sensitivity and specificity for a wide range of emerging contaminants.

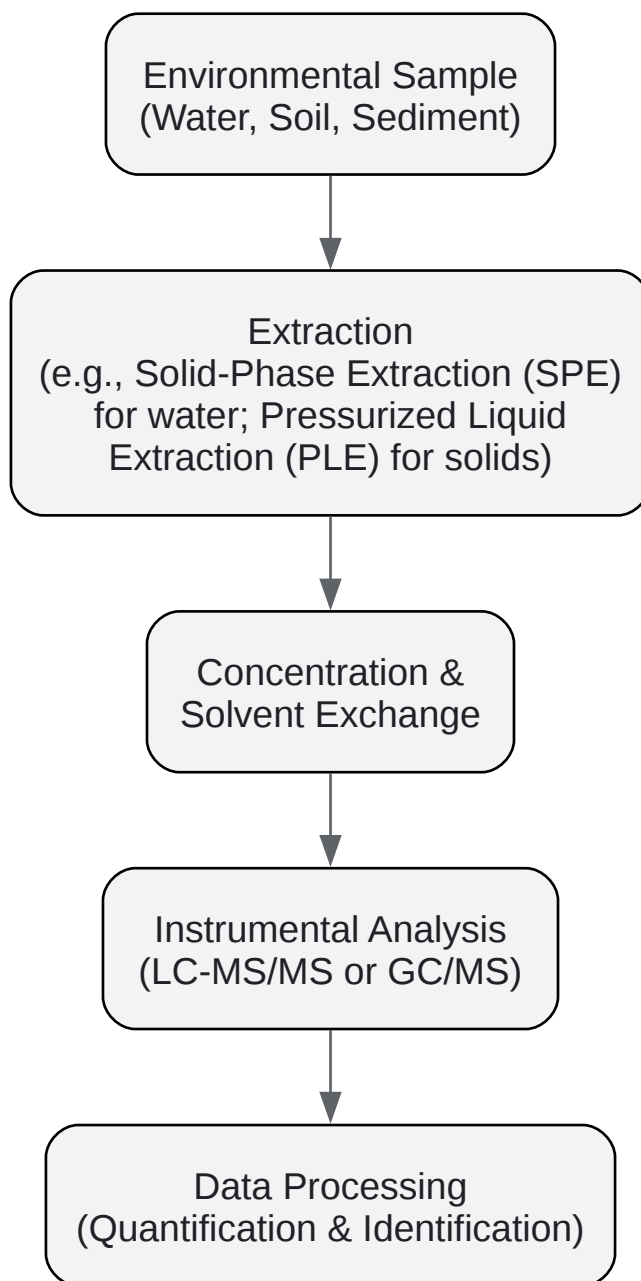

[Click to download full resolution via product page](#)

Caption: General analytical workflow for determining DOHA in environmental samples.

## Conclusion and Outlook

Based on its chemical structure and analogies to similar compounds, **N,N-Dioctylhexanamide** is predicted to be a persistent and potentially bioaccumulative substance. Its primary environmental sinks are likely to be soil and sediment due to strong sorption. Key degradation

pathways like hydrolysis and direct photolysis are expected to be negligible. The most significant uncertainty lies in its susceptibility to biodegradation, which requires experimental confirmation.

To move from prediction to definitive characterization, the following research is critical:

- Experimental determination of fundamental physicochemical properties (Log Kow, water solubility).
- Standardized testing for ready biodegradability (e.g., OECD 301B) and, if not readily biodegradable, inherent biodegradability and simulation testing (e.g., OECD 308, 309).
- Bioaccumulation studies in fish (OECD 305) to quantify its BCF.
- Identification of transformation products from any observed degradation to fully assess the environmental risk.

By following the structured approach outlined in this guide, researchers can systematically fill these knowledge gaps and perform a comprehensive environmental risk assessment for **N,N-Dioctylhexanamide**.

## References

- Cheméo. (n.d.). Hexanamide, N,N-dioctyl-6-chloro- - Chemical & Physical Properties. Retrieved from [\[Link\]](#)
- Sasaki, Y., Sugo, Y., Suzuki, S., & Tachimori, S. (2001). Studies on hydrolysis and radiolysis of N,N,N',N'-tetraoctyl-3-oxapentane-1,5-diamide. *Solvent Extraction and Ion Exchange*, 19(1), 91-105. Retrieved from [\[Link\]](#)
- NIST. (n.d.). Hexanamide, N,N-dioctyl-. NIST Chemistry WebBook. Retrieved from [\[Link\]](#)
- Weeks, J. A., Gu, A., & Adams, C. D. (2012). Assessment of the environmental fate and ecotoxicity of N,N-diethyl-m-toluamide (DEET). *Integrated Environmental Assessment and Management*, 8(1), 126-138. Retrieved from [\[Link\]](#)
- Papakyriakou, A., Zikos, C., & Detsi, A. (2015). A mild alkaline hydrolysis of N- and N,N-substituted amides and nitriles. *Arkivoc*, 2015(7), 101-112. Retrieved from [\[Link\]](#)

- Montesdeoca-Esponda, S., et al. (2021). An overview of analytical methods for enantiomeric determination of chiral pollutants in environmental samples and biota. *TrAC Trends in Analytical Chemistry*, 142, 116323. Retrieved from [\[Link\]](#)
- Armitage, J. M., et al. (2013). ASSESSING THE BIOACCUMULATION POTENTIAL OF IONIZABLE ORGANIC COMPOUNDS: CURRENT KNOWLEDGE AND RESEARCH PRIORITIES. *Environmental Toxicology and Chemistry*, 32(1), 98-111. Retrieved from [\[Link\]](#)
- OpenStax. (2023, September 20). 21.7 Chemistry of Amides. Retrieved from [\[Link\]](#)
- Ternes, T. A. (1998). Occurrence of drugs in German sewage treatment plants and rivers. *Water Research*, 32(11), 3245-3260. Retrieved from [\[Link\]](#)
- U.S. Environmental Protection Agency. (2020). New Approach for Evaluating the Bioaccumulation Potential of Metals in the New Chemicals Division. Retrieved from [\[Link\]](#)
- Eljarrat, E., & Barceló, D. (2011). Recent advances in analytical methodologies based on mass spectrometry for the environmental analysis of halogenated organic contaminants. *Journal of Chromatography A*, 1218(49), 8757-8767. Retrieved from [\[Link\]](#)
- Dodard, S. G., et al. (2014). Environmental fate and ecological impact of emerging energetic chemicals (ADN, DNAN and its Amino-Derivatives, PETN). DTIC. Retrieved from [\[Link\]](#)
- DeLeo, P. C., et al. (2020). Assessment of ecological hazards and environmental fate of disinfectant quaternary ammonium compounds. *Ecotoxicology and Environmental Safety*, 206, 111116. Retrieved from [\[Link\]](#)
- Amat, A. M., et al. (2005). Photodegradation of Hydroxylated N-heteroaromatic Derivatives in Natural-Like Aquatic Environments. A Review of Kinetic Data of Pesticide Model Compounds. *Photochemistry and Photobiology*, 81(3), 517-532. Retrieved from [\[Link\]](#)
- Furlong, E. T., et al. (2017). Analytical Methods for the Determination of Pharmaceuticals and Personal Care Products in Solid and Liquid Environmental Matrices: A Review. *Journal of AOAC International*, 100(4), 887-907. Retrieved from [\[Link\]](#)
- Peaslee, G. F. (2023). Development of Analytical Methods for Highly Selective and Sensitive Analysis of Compounds Relevant to Human Health and the Environment. University of Notre

Dame. Retrieved from [\[Link\]](#)

- DeLeo, P. C., et al. (2020). Assessment of ecological hazards and environmental fate of disinfectant quaternary ammonium compounds. ResearchGate. Retrieved from [\[Link\]](#)
- Cheméo. (n.d.). Hexanamide, N,N-diundecyl-6-bromo- - Chemical & Physical Properties. Retrieved from [\[Link\]](#)
- Cheméo. (n.d.). Hexanamide, N-butyl - Chemical & Physical Properties. Retrieved from [\[Link\]](#)
- Papakyriakou, A., Zikos, C., & Detsi, A. (2015). A mild alkaline hydrolysis of N- and N,N-substituted amides and nitriles. Arkivoc. Retrieved from [\[Link\]](#)
- Goulson, D. (2015). Environmental fate and exposure; neonicotinoids and fipronil. Environmental Science and Pollution Research, 22(1), 35-55. Retrieved from [\[Link\]](#)
- Zhang, C., et al. (2023). The impact of N,N-diethyl-m-toluamide in aquatic environments occurrence, fate, and ecological risk. Water Emerging Contaminants & Nanoplastics, 2(1), 1-13. Retrieved from [\[Link\]](#)
- Ashenhurst, J. (2019, October 7). Amide Hydrolysis Using Acid Or Base. Master Organic Chemistry. Retrieved from [\[Link\]](#)
- Vione, D., et al. (2021). Photochemical degradation of the aromatic amine 4-(N,N-dimethylamino)benzotrile: Triplet sensitisation, back reduction, and (quasi-)global modelling. Journal of Environmental Chemical Engineering, 9(2), 105086. Retrieved from [\[Link\]](#)
- Svobodova, Z., et al. (2014). Effects of Subchronic Exposure to N,N-Diethyl-m-toluamide on Selected Biomarkers in Common Carp (Cyprinus carpio L.). BioMed Research International, 2014, 962483. Retrieved from [\[Link\]](#)
- Bhatt, P., et al. (2020). Insights Into the Biodegradation of Lindane ( $\gamma$ -Hexachlorocyclohexane) Using a Microbial System. Frontiers in Microbiology, 11, 1033. Retrieved from [\[Link\]](#)

- Chang, W., & Lai, Y. C. (2002). Degradation of n-Hexadecane and Its Metabolites by *Pseudomonas aeruginosa* under Microaerobic and Anaerobic Denitrifying Conditions. *Applied and Environmental Microbiology*, 68(2), 922-928. Retrieved from [[Link](#)]
- Grandclément, C., et al. (2014). Photodegradation of Sulfonamides and Their N (4)-acetylated Metabolites in Water by Simulated Sunlight Irradiation: Kinetics and Identification of Photoproducts. *Environmental Science & Technology*, 48(1), 347-355. Retrieved from [[Link](#)]
- Hawari, J., et al. (2000). Characterization of Metabolites during Biodegradation of Hexahydro-1,3,5-Trinitro-1,3,5-Triazine (RDX) with Municipal Anaerobic Sludge. *Applied and Environmental Microbiology*, 66(6), 2652-2657. Retrieved from [[Link](#)]
- Weeks, J. A., et al. (2012). Assessment of the environmental fate and ecotoxicity of N,N-diethyl-m-toluamide (DEET). ResearchGate. Retrieved from [[Link](#)]

### Need Custom Synthesis?

BenchChem offers custom synthesis for rare earth carbides and specific isotopic labeling.

Email: [info@benchchem.com](mailto:info@benchchem.com) or [Request Quote Online](#).

## Sources

- 1. Hexanamide, N,N-dioctyl- [[webbook.nist.gov](http://webbook.nist.gov)]
- 2. [researchgate.net](http://researchgate.net) [[researchgate.net](http://researchgate.net)]
- 3. [arkat-usa.org](http://arkat-usa.org) [[arkat-usa.org](http://arkat-usa.org)]
- 4. [quod.lib.umich.edu](http://quod.lib.umich.edu) [[quod.lib.umich.edu](http://quod.lib.umich.edu)]
- 5. [apps.dtic.mil](http://apps.dtic.mil) [[apps.dtic.mil](http://apps.dtic.mil)]
- 6. ASSESSING THE BIOACCUMULATION POTENTIAL OF IONIZABLE ORGANIC COMPOUNDS: CURRENT KNOWLEDGE AND RESEARCH PRIORITIES - PMC [[pmc.ncbi.nlm.nih.gov](http://pmc.ncbi.nlm.nih.gov)]
- 7. [pmc.ncbi.nlm.nih.gov](http://pmc.ncbi.nlm.nih.gov) [[pmc.ncbi.nlm.nih.gov](http://pmc.ncbi.nlm.nih.gov)]
- 8. 21.7 Chemistry of Amides - Organic Chemistry | OpenStax [[openstax.org](https://openstax.org)]
- 9. [masterorganicchemistry.com](http://masterorganicchemistry.com) [[masterorganicchemistry.com](http://masterorganicchemistry.com)]

- [10. boa.unimib.it](http://boa.unimib.it) [[boa.unimib.it](http://boa.unimib.it)]
- [11. Frontiers | Insights Into the Biodegradation of Lindane \( \$\gamma\$ -Hexachlorocyclohexane\) Using a Microbial System](https://doi.org/10.3389/fmicb.2017.01281) [[frontiersin.org](https://doi.org/10.3389/fmicb.2017.01281)]
- [12. Degradation of n-Hexadecane and Its Metabolites by Pseudomonas aeruginosa under Microaerobic and Anaerobic Denitrifying Conditions - PMC](https://pubmed.ncbi.nlm.nih.gov/27511111/) [[pmc.ncbi.nlm.nih.gov](https://pubmed.ncbi.nlm.nih.gov/27511111/)]
- [13. Environmental fate and exposure; neonicotinoids and fipronil - PMC](https://pubmed.ncbi.nlm.nih.gov/27511111/) [[pmc.ncbi.nlm.nih.gov](https://pubmed.ncbi.nlm.nih.gov/27511111/)]
- [14. employees.csbsju.edu](http://employees.csbsju.edu) [[employees.csbsju.edu](http://employees.csbsju.edu)]
- [15. researchgate.net](https://www.researchgate.net) [[researchgate.net](https://www.researchgate.net)]
- [16. pdfs.semanticscholar.org](https://pdfs.semanticscholar.org) [[pdfs.semanticscholar.org](https://pdfs.semanticscholar.org)]
- [17. curate.nd.edu](http://curate.nd.edu) [[curate.nd.edu](http://curate.nd.edu)]
- To cite this document: BenchChem. ["environmental fate of N,N-Dioctylhexanamide"]. BenchChem, [2026]. [Online PDF]. Available at: [<https://www.benchchem.com/product/b13935190/docs#environmental-fate-of-n-n-dioctylhexanamide>]

---

### Disclaimer & Data Validity:

The information provided in this document is for Research Use Only (RUO) and is strictly not intended for diagnostic or therapeutic procedures. While BenchChem strives to provide accurate protocols, we make no warranties, express or implied, regarding the fitness of this product for every specific experimental setup.

**Technical Support:** The protocols provided are for reference purposes. Unsure if this reagent suits your experiment?

**Need Industrial/Bulk Grade?** [Request Custom Synthesis Quote](#)

# BenchChem

Our mission is to be the trusted global source of essential and advanced chemicals, empowering scientists and researchers to drive progress in science and industry.

## Contact

Address: 3281 E Guasti Rd

Ontario, CA 91761, United States

Phone: (601) 213-4426

Email: [info@benchchem.com](mailto:info@benchchem.com)

[Contact our Ph.D. Support Team for a compatibility check](#)