

# reaction condition optimization for pyrazole synthesis

**Author:** BenchChem Technical Support Team. **Date:** April 2026

## Compound of Interest

Compound Name: 5-(2-hydroxyethyl)-1H-pyrazole-3-carboxamide

CAS No.: 1312205-25-6

Cat. No.: B1393540

[Get Quote](#)

## Pyrazole Synthesis Technical Support Center

Welcome to the Technical Support Center for Pyrazole Synthesis. This guide is designed for researchers, scientists, and professionals in drug development, providing in-depth, experience-based solutions to common and complex challenges encountered during the synthesis of pyrazole derivatives. Our goal is to move beyond simple procedural steps to explain the underlying chemical principles, empowering you to optimize your reaction conditions effectively.

### Part 1: Frequently Asked Questions (FAQs)

This section addresses high-level, common questions regarding pyrazole synthesis, particularly focusing on the widely used Knorr synthesis and its variations.

Q1: What is the most common and versatile method for synthesizing substituted pyrazoles?

A1: The Knorr pyrazole synthesis is arguably the most prevalent and versatile method. It involves the cyclocondensation reaction between a 1,3-dicarbonyl compound (or its synthetic equivalent) and a hydrazine derivative.<sup>[1][2]</sup> This method's popularity stems from its use of

readily available starting materials and its tolerance for a wide variety of substituents, allowing for the creation of diverse compound libraries essential for drug discovery.[2]

Q2: What is the fundamental mechanism of the Knorr pyrazole synthesis?

A2: The reaction proceeds through a series of well-understood steps. First, one of the nitrogen atoms of the hydrazine acts as a nucleophile, attacking one of the carbonyl carbons of the 1,3-dicarbonyl compound.[1] This is followed by the elimination of a water molecule to form a hydrazone or enamine intermediate. The second nitrogen of the hydrazine then performs an intramolecular nucleophilic attack on the other carbonyl carbon, leading to a non-aromatic cyclic intermediate. A final dehydration step results in the formation of the stable, aromatic pyrazole ring.[1] The reaction is typically catalyzed by an acid.[3][4][5]

Q3: How do I choose the appropriate starting materials (1,3-dicarbonyl and hydrazine)?

A3: The choice of starting materials directly dictates the substitution pattern of the final pyrazole product.

- **1,3-Dicarbonyl Compound:** The structure of this reactant determines the substituents at positions 3 and 5 of the pyrazole ring. If you use an unsymmetrical dicarbonyl (e.g., a  $\beta$ -ketoester), you introduce the possibility of forming two different regioisomers, a significant challenge that is addressed in the troubleshooting section.[6][7]
- **Hydrazine Derivative:** Using hydrazine hydrate ( $\text{NH}_2\text{NH}_2 \cdot \text{H}_2\text{O}$ ) will result in an N-unsubstituted pyrazole (an N-H bond at position 1). Using a substituted hydrazine (e.g., phenylhydrazine or methylhydrazine) will install that substituent at the N1 position of the ring. [2] Be aware that hydrazine and its derivatives can be toxic and may degrade over time; using fresh, high-purity reagents is critical.[1][8]

Q4: What is the role of the catalyst, and how do I select one?

A4: Catalysts, typically acids, accelerate the reaction by protonating a carbonyl group, which increases its electrophilicity and facilitates the initial nucleophilic attack by the hydrazine.[3][4]

- **Acid Catalysts:** Glacial acetic acid is a commonly used and effective catalyst.[1] Other acids like p-toluenesulfonic acid (pTSA) can also be employed. The amount should be catalytic, as excessive acid can lead to side reactions like hydrolysis of the starting materials.[8]

- Base Catalysts: In some specific syntheses, bases may be used to promote different reaction pathways or control regioselectivity.[8] For instance, sodium ethoxide in ethanol can favor one regioisomer over another when using specific substrates.[8]

## Part 2: In-Depth Troubleshooting Guide

This section provides a structured approach to diagnosing and solving specific experimental problems.

### Issue 1: Low or No Product Yield

A low yield is one of the most common frustrations in synthesis. A systematic investigation of potential causes is the most effective approach.

Troubleshooting Workflow for Low Yield

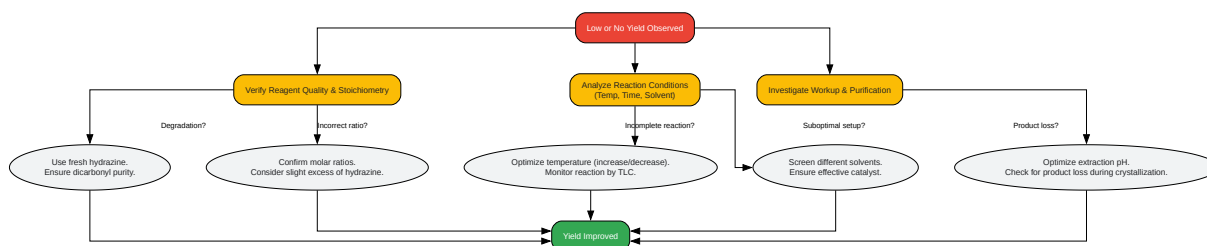

[Click to download full resolution via product page](#)

Caption: A systematic workflow for troubleshooting low pyrazole yield.

Potential Cause	Underlying Rationale & Explanation	Recommended Solution
1. Poor Reagent Quality	Hydrazine and its derivatives are susceptible to oxidation and degradation over time.[1][8] $\beta$ -Ketonitriles or other dicarbonyl compounds can hydrolyze, especially in the presence of acidic or basic impurities.[8] This reduces the concentration of active starting materials available for the reaction.	Use a freshly opened bottle of hydrazine or purify it before use.[8] Run the reaction under an inert atmosphere (N <sub>2</sub> or Ar) to prevent air oxidation.[1] Ensure the purity of the 1,3-dicarbonyl compound.
2. Suboptimal Reaction Conditions	The condensation reaction is sensitive to temperature and time. Insufficient heat or time may lead to an incomplete reaction. Conversely, excessive heat can cause degradation of reactants or products.[8] The choice of solvent can also significantly impact reaction rates and yields.	Monitor the reaction progress diligently using Thin Layer Chromatography (TLC) or LC-MS to determine the optimal reaction time.[1][8] If the reaction is sluggish, consider cautiously increasing the temperature or switching to a higher-boiling solvent like ethanol or toluene.[9]
3. Ineffective Catalysis	An insufficient amount of catalyst, or a deactivated catalyst, will result in a slow or stalled reaction. The pH of the reaction is crucial; conditions that are too acidic or too basic can promote side reactions like hydrolysis over the desired cyclization.[8]	Ensure the correct catalytic amount of a suitable acid (e.g., glacial acetic acid) is used. If using a base, ensure it is appropriate for the specific substrate combination. For some reactions, pH control can be critical for maximizing yield.[8]
4. Competing Side Reactions	Depending on the substrates, alternative cyclization	Modify reaction conditions to disfavor side reactions. This

pathways can lead to undesired heterocyclic products.[8] Self-condensation of the dicarbonyl compound or decomposition pathways can also consume starting materials.

could involve lowering the temperature, changing the solvent, or adjusting the pH.[8] A thorough literature search for your specific substrate class is highly recommended.

## Issue 2: Formation of a Mixture of Regioisomers

When using an unsymmetrical 1,3-dicarbonyl compound, the formation of two regioisomers is a frequent and significant challenge, as they can be difficult to separate and may exhibit different biological activities.[6][7]

### Simplified Mechanism of Regioisomer Formation

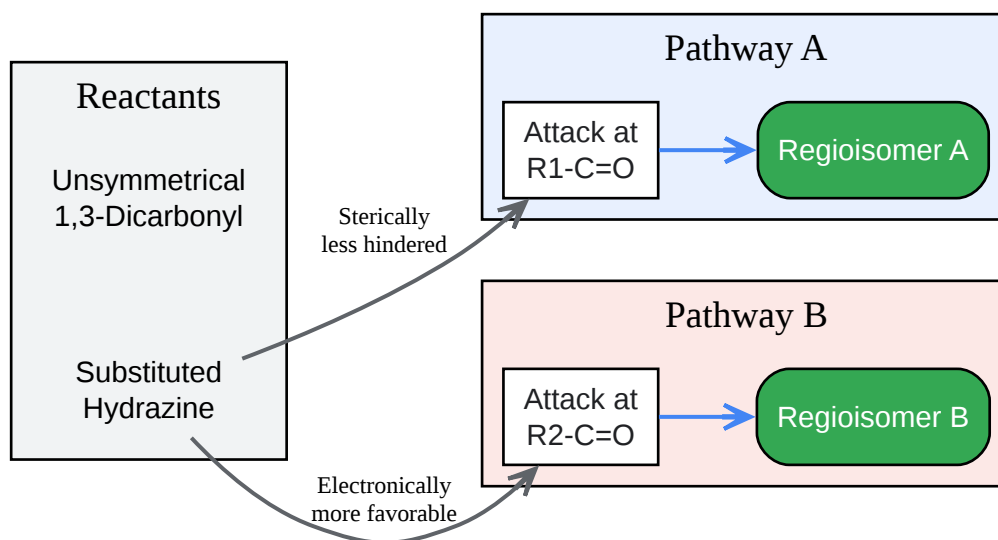

[Click to download full resolution via product page](#)

Caption: Two competing pathways leading to different regioisomers.

Controlling Factor	Underlying Rationale & Explanation	Recommended Strategy
1. Steric Effects	<p>The initial nucleophilic attack by the hydrazine is often directed to the less sterically hindered carbonyl group.[6][7]</p> <p>A bulky substituent (e.g., a t-butyl group) on the dicarbonyl or on the hydrazine can strongly influence the regiochemical outcome.</p>	<p>Substrate Design: If possible, design your synthesis with a dicarbonyl or hydrazine that has a bulky substituent to sterically block one of the carbonyl groups, thereby directing the reaction towards a single isomer.[8]</p>
2. Electronic Effects	<p>The relative electrophilicity of the two carbonyl carbons is a key determinant. Electron-withdrawing groups (like -CF<sub>3</sub>) near a carbonyl carbon make it more electron-deficient and thus a more favorable site for nucleophilic attack.[6][7]</p>	<p>pH Control: The reaction's regioselectivity can be highly pH-dependent. Acidic conditions may favor one isomer, while basic conditions favor another.[8]</p> <p>Systematically screen the reaction under acidic (e.g., acetic acid), neutral, and basic (e.g., sodium ethoxide) conditions to find the optimal selectivity.</p>
3. Solvent Choice	<p>Solvents can influence the reaction pathway through their polarity and hydrogen-bonding properties. Fluorinated alcohols, for example, have been shown to dramatically improve regioselectivity in certain cases.[6][7]</p> <p>Aprotic dipolar solvents like DMF can also yield better results than protic solvents like ethanol.[8]</p>	<p>Solvent Screening: Conduct small-scale parallel reactions in a variety of solvents. Compare a standard protic solvent (ethanol) with an aprotic polar solvent (DMF) and a fluorinated alcohol (e.g., 2,2,2-trifluoroethanol) to assess the impact on the regioisomeric ratio.[7]</p>

Confirming Regiochemistry: Unambiguous characterization of the obtained isomers is critical. The most definitive method is 2D NMR spectroscopy, specifically the Nuclear Overhauser Effect Spectroscopy (NOESY) experiment, which can establish the spatial proximity between protons on the N1-substituent and the C5-substituent.[6]

### **Issue 3: Product Purification Challenges**

Even with a successful reaction, isolating the pure pyrazole can be difficult due to unreacted starting materials or the presence of hard-to-separate isomers.

Problem	Potential Cause	Recommended Solution
1. Oily Product / Failure to Crystallize	The product may be an oil due to residual solvent or impurities that depress the melting point.	High-Vacuum Evaporation: Ensure all volatile solvents are thoroughly removed using a rotary evaporator followed by drying on a high-vacuum line. [10] Purification: If the oil persists, column chromatography is a highly effective method for purifying oily products.[10]
2. Difficulty Removing Unreacted Starting Materials	Dicarbonyl compounds and hydrazine derivatives can have polarities similar to the pyrazole product, making separation challenging.	Aqueous Wash: Perform an acidic wash (e.g., dilute HCl) to protonate and remove any unreacted basic hydrazine. Follow with a basic wash (e.g., NaHCO <sub>3</sub> ) to remove any acidic starting materials or byproducts. Column Chromatography: This is the most robust method. A carefully chosen solvent system (e.g., ethyl acetate/hexanes gradient) can effectively separate the product from starting materials. [10]
3. Inability to Separate Regioisomers	Regioisomers often have very similar physical properties (polarity, boiling point), making their separation by standard chromatography or distillation difficult.[6][11]	Optimize Chromatography: Experiment with different stationary phases (e.g., alumina instead of silica gel) or different solvent systems.[10] Preparative HPLC or GC can be powerful but are often limited to smaller scales.[11] Salt Formation &

Crystallization: This is a highly effective classical technique. React the isomer mixture with an acid to form acid-addition salts. These salts may have different crystallization properties, allowing one isomer to be selectively crystallized and isolated. The pure pyrazole free base is then regenerated by neutralization. [\[11\]](#)[\[12\]](#)

---

## Part 3: Advanced Methodologies & Protocols

### Protocol: Microwave-Assisted Pyrazole Synthesis

Microwave irradiation has emerged as a powerful tool in organic synthesis, often leading to dramatically reduced reaction times, increased yields, and cleaner reactions compared to conventional heating.[\[13\]](#)[\[14\]](#) This is due to efficient and uniform heating of the reaction mixture.

Optimizing Microwave Conditions:

Parameter	Rationale	Typical Range
Power (W)	Controls the rate of energy input. Too high can cause pressure buildup or degradation; too low results in a slow reaction.	100 - 420 W[15][16]
Temperature (°C)	Directly influences reaction rate. The sealed-vessel capability of microwave reactors allows for superheating solvents above their atmospheric boiling points.	40 - 120 °C[14]
Time (min)	Significantly shorter than conventional methods.	5 - 20 min[14][16]

#### General Protocol:

- In a dedicated microwave reaction vessel, combine the 1,3-dicarbonyl compound (1.0 mmol), hydrazine derivative (1.1-1.2 mmol), and a suitable solvent (e.g., ethanol, water, or solvent-free).[15]
- Add a catalytic amount of acid or base if required.
- Seal the vessel and place it in the microwave reactor.
- Irradiate at a set temperature (e.g., 100 °C) and power (e.g., 200 W) for a predetermined time (e.g., 15 min).[15]
- After the reaction, cool the vessel to room temperature before opening.
- Work up the reaction mixture as per standard procedures (e.g., solvent evaporation, extraction, and crystallization).

## Focus on Green Chemistry

Modern drug development emphasizes sustainability. Several green chemistry approaches have been successfully applied to pyrazole synthesis, aiming to reduce waste and avoid hazardous materials.[17][18]

- **Water as a Solvent:** Performing the reaction in water can replace volatile organic solvents, offering significant environmental benefits.[19]
- **Solvent-Free Conditions:** Reactions can be run neat or with a recyclable catalyst like tetrabutylammonium bromide (TBAB), eliminating the need for a solvent entirely.[9]
- **Reusable Catalysts:** The use of heterogeneous or recyclable catalysts simplifies purification and reduces waste.

These methods not only align with sustainability goals but can also offer advantages in terms of simplified workup and cost-effectiveness.[9]

## References

- Al-Amiery, A. A., Kadhum, A. A. H., & Mohamad, A. B. (2014). Green Synthetic Strategies for Pyrazole Derivatives: A Comprehensive Review. *Molecules*, 19(11), 18897-18937. Available at: [\[Link\]](#)
- Ghahremanzadeh, R., Fereshteh, Z., & Bazgir, A. (2017). Green synthesis of pyrazole systems under solvent-free conditions. *Phosphorus, Sulfur, and Silicon and the Related Elements*, 192(8), 923-928. Available at: [\[Link\]](#)
- Singh, S., Singh, A., & Singh, K. N. (2023). Green Synthesis of Pyrazoles: Recent Developments in Aqueous Methods. *ChemistrySelect*, 8(25), e202301548. Available at: [\[Link\]](#)
- Gawande, M. B., Zboril, R., & Varma, R. S. (2016). Green synthesis of dihydropyrano [2,3-c] pyrazole by using eco-friendly catalyst. *International Journal for Scientific Research & Development*, 4(4), 123-128. Available at: [\[Link\]](#)
- Kumar, A., & Kumar, V. (2025). Green Synthetic Strategies for Pyrazole Derivatives: A Comprehensive Review. *Journal of Heterocyclic Chemistry*. Available at: [\[Link\]](#)

- Knorr Pyrazole Synthesis. Name-Reaction.com. Available at: [\[Link\]](#)
- Knorr pyrrole synthesis. Wikipedia. Available at: [\[Link\]](#)
- Kumar, A., & Kumar, V. (2022). Microwave-Assisted, Multicomponent Synthesis of Pyrazolo [3, 4-b] Pyridines Under Green Conditions. ChemistrySelect, 7(38), e202202935. Available at: [\[Link\]](#)
- Knorr Pyrazole Synthesis (M. Pharm). Slideshare. Available at: [\[Link\]](#)
- Christodoulou, E., et al. (2025). Microwave Assisted Synthesis of Antioxidant Dihydro-Pyrazole Hybrids as Possible Lipoxygenase Inhibitors. Molecules, 30(10), 2345. Available at: [\[Link\]](#)
- Li, J., et al. (2010). Microwave-Assisted One-Pot Synthesis of Pyrazolone Derivatives under Solvent-Free Conditions. Molecules, 15(5), 3593-3601. Available at: [\[Link\]](#)
- Patel, R. V., et al. (2021). Conventional and Microwave-Assisted Synthesis, Antitubercular Activity, and Molecular Docking Studies of Pyrazole and Oxadiazole Hybrids. ACS Omega, 6(42), 27937-27951. Available at: [\[Link\]](#)
- Kumar, A., & Kumar, V. (2025). Recent advances in the synthesis of anticancer pyrazole derivatives using microwave, ultrasound, and mechanochemical techniques. RSC Medicinal Chemistry. Available at: [\[Link\]](#)
- Pyrazole synthesis. Organic Chemistry Portal. Available at: [\[Link\]](#)
- Synthesis and evaluation of pyrazole derivatives by using green catalyst. (2024). Journal of Emerging Technologies and Innovative Research, 11(6). Available at: [\[Link\]](#)
- Synthesis and Properties of Pyrazoles. (2022). Encyclopedia.pub. Available at: [\[Link\]](#)
- Process for the purification of pyrazoles. (2011). Google Patents.
- Wang, Y., et al. (2018). Regio- and Stereoselective Switchable Synthesis of (E)- and (Z)-N-Carbonylvinyllated Pyrazoles. Molecules, 23(11), 2947. Available at: [\[Link\]](#)

- Recent Developments in Reactions and Catalysis of Protic Pyrazole Complexes. (2019). *Molecules*, 24(18), 3326. Available at: [\[Link\]](#)
- Direct Preparation of N-Substituted Pyrazoles from Primary Aliphatic or Aromatic Amines. (2021). *The Journal of Organic Chemistry*, 86(14), 9572-9582. Available at: [\[Link\]](#)
- Preparation, separation and characterization of two pyrazolic regioisomers of high purity. (2011). UAB Barcelona. Available at: [\[Link\]](#)
- Katritzky, A. R., et al. (2001). Regioselective synthesis of polysubstituted pyrazoles and isoxazoles. *Journal of Organic Chemistry*, 66(20), 6787-6791. Available at: [\[Link\]](#)
- Direct Preparation of N-Substituted Pyrazoles from Primary Aliphatic or Aromatic Amines. (2021). *The Journal of Organic Chemistry*. Available at: [\[Link\]](#)
- Recent Advances in Synthesis and Properties of Pyrazoles. (2022). MDPI. Available at: [\[Link\]](#)
- Synthesis, Reactions and Medicinal Uses of Pyrazole. (2023). Pharmaguideline. Available at: [\[Link\]](#)
- Pyrazole Scaffold: Strategies toward the Synthesis and Their Applications. (2022). IntechOpen. Available at: [\[Link\]](#)
- Green multicomponent synthesis of pyrano[2,3-c]pyrazole derivatives: current insights and future directions. (2023). RSC Publishing. Available at: [\[Link\]](#)
- 194 recent advances in the synthesis of new pyrazole derivatives. (n.d.). Available at: [\[Link\]](#)

### Need Custom Synthesis?

BenchChem offers custom synthesis for rare earth carbides and specific isotopic labeling.

Email: [info@benchchem.com](mailto:info@benchchem.com) or [Request Quote Online](#).

## Sources

- [1. pdf.benchchem.com](https://pdf.benchchem.com) [[pdf.benchchem.com](#)]

- [2. pdf.benchchem.com \[pdf.benchchem.com\]](#)
- [3. name-reaction.com \[name-reaction.com\]](#)
- [4. jk-sci.com \[jk-sci.com\]](#)
- [5. Knorr Pyrazole Synthesis \(M. Pharm\) | PPTX \[slideshare.net\]](#)
- [6. pdf.benchchem.com \[pdf.benchchem.com\]](#)
- [7. pdf.benchchem.com \[pdf.benchchem.com\]](#)
- [8. pdf.benchchem.com \[pdf.benchchem.com\]](#)
- [9. tandfonline.com \[tandfonline.com\]](#)
- [10. pdf.benchchem.com \[pdf.benchchem.com\]](#)
- [11. pdf.benchchem.com \[pdf.benchchem.com\]](#)
- [12. DE102009060150A1 - Process for the purification of pyrazoles - Google Patents \[patents.google.com\]](#)
- [13. pubs.acs.org \[pubs.acs.org\]](#)
- [14. Recent advances in the synthesis of anticancer pyrazole derivatives using microwave, ultrasound, and mechanochemical techniques - RSC Advances \(RSC Publishing\) DOI:10.1039/D4RA08866B \[pubs.rsc.org\]](#)
- [15. mdpi.com \[mdpi.com\]](#)
- [16. Microwave-Assisted One-Pot Synthesis of Pyrazolone Derivatives under Solvent-Free Conditions - PMC \[pmc.ncbi.nlm.nih.gov\]](#)
- [17. Green Synthetic Strategies for Pyrazole Derivatives: A Comprehensive Review - PubMed \[pubmed.ncbi.nlm.nih.gov\]](#)
- [18. researchgate.net \[researchgate.net\]](#)
- [19. thieme-connect.com \[thieme-connect.com\]](#)
- To cite this document: BenchChem. [reaction condition optimization for pyrazole synthesis]. BenchChem, [2026]. [Online PDF]. Available at: [\[https://www.benchchem.com/product/b1393540/docs#reaction-condition-optimization-for-pyrazole-synthesis\]](https://www.benchchem.com/product/b1393540/docs#reaction-condition-optimization-for-pyrazole-synthesis)

---

### Disclaimer & Data Validity:

The information provided in this document is for Research Use Only (RUO) and is strictly not intended for diagnostic or therapeutic procedures. While BenchChem strives to provide

accurate protocols, we make no warranties, express or implied, regarding the fitness of this product for every specific experimental setup.

**Technical Support:** The protocols provided are for reference purposes. Unsure if this reagent suits your experiment?

**Need Industrial/Bulk Grade?** [Request Custom Synthesis Quote](#)

## BenchChem

Our mission is to be the trusted global source of essential and advanced chemicals, empowering scientists and researchers to drive progress in science and industry.

### Contact

Address: 3281 E Guasti Rd

Ontario, CA 91761, United States

Phone: (601) 213-4426

Email: [info@benchchem.com](mailto:info@benchchem.com)

[Contact our Ph.D. Support Team for a compatibility check](#)