

Technical Support Center: Synthesis of 1-(6-Chloro-2-pyridinyl)indoline

Author: BenchChem Technical Support Team. **Date:** April 2026

Compound of Interest

Compound Name: 1-(6-Chloro-2-pyridinyl)indoline

CAS No.: 1220036-30-5

Cat. No.: B1392376

[Get Quote](#)

Prepared by the Senior Application Scientist Team

Welcome to the technical support center for the synthesis of **1-(6-Chloro-2-pyridinyl)indoline**. This guide is designed for researchers, medicinal chemists, and process development scientists. Here, we provide in-depth troubleshooting guides, frequently asked questions (FAQs), and detailed experimental protocols for the common synthetic routes to this important heterocyclic scaffold. Our focus is on providing practical, field-proven insights to help you overcome common experimental hurdles.

Core Synthetic Strategies

The formation of the C-N bond between the indoline nitrogen and the chloropyridine ring is the key transformation. The two most robust and widely employed methods for this N-arylation are the Palladium-catalyzed Buchwald-Hartwig amination and the Copper-catalyzed Ullmann condensation.^{[1][2]} The primary challenge in synthesizing **1-(6-Chloro-2-pyridinyl)indoline** lies in achieving selective mono-substitution on the 2,6-dichloropyridine substrate, preventing the formation of the undesired di-substituted byproduct.

Troubleshooting Guide (Q&A Format)

This section addresses specific issues you may encounter during your experiments.

Issue 1: Low or No Yield of the Desired Product

Question: I am not getting any, or very little, of the desired **1-(6-chloro-2-pyridinyl)indoline**. What are the likely causes and how can I fix it?

Answer: This is a common problem in cross-coupling reactions and can stem from several factors related to the catalyst, reagents, or reaction conditions.

Potential Causes & Solutions:

- Inactive Catalyst: The Pd(0) or Cu(I) species is the active catalyst. If your reaction fails, the catalyst may not have been activated or may have decomposed.
 - Expert Insight: For Buchwald-Hartwig reactions using a Pd(II) precatalyst like Pd(OAc)₂, the reduction to Pd(0) is a critical first step.^[3] This is often accomplished by the phosphine ligand or the amine substrate itself. Ensure your phosphine ligand is not oxidized. For Ullmann reactions, the copper source (often CuI) should be of high purity; older bottles can become oxidized.
 - Troubleshooting Steps:
 - Use a fresh, high-purity palladium or copper precatalyst.
 - Ensure your phosphine ligand has been stored under inert gas and handled properly.
 - Degas your solvent thoroughly (e.g., by sparging with argon for 20-30 minutes or via freeze-pump-thaw cycles) to remove oxygen, which can deactivate the catalyst.
- Incorrect Base or Solvent: The choice of base and solvent is critical and interdependent.
 - Expert Insight: In Buchwald-Hartwig aminations, a strong, non-nucleophilic base is required. Sodium tert-butoxide (NaOt-Bu) is common, but its high reactivity can sometimes promote side reactions. Weaker bases like potassium phosphate (K₃PO₄) or cesium carbonate (Cs₂CO₃) can be effective, especially with sensitive substrates.^{[1][4]} The

solvent must be anhydrous and capable of solubilizing the reactants and catalyst complex. Toluene and dioxane are standard choices.[1] For Ullmann reactions, strong bases like K_2CO_3 or Cs_2CO_3 are often used in polar aprotic solvents like DMF or NMP to facilitate the reaction, which typically requires higher temperatures.[5]

- Troubleshooting Steps:
 - Ensure the base is freshly opened or has been stored in a desiccator. Carbonates and phosphates are hygroscopic.
 - Dry your solvent over molecular sieves or by distillation before use.
 - If using NaOt-Bu fails, try switching to K_3PO_4 or Cs_2CO_3 .
- Poor Reagent Quality:
 - Expert Insight: Indoline can oxidize over time if not stored properly. 2,6-Dichloropyridine should be pure.
 - Troubleshooting Steps:
 - Check the purity of your starting materials by NMR or GC-MS.
 - If necessary, purify indoline by distillation or column chromatography before use.

Issue 2: Formation of a Major Di-substituted Byproduct

Question: My main product is the di-indoline substituted pyridine, not the mono-substituted product I want. How do I improve selectivity?

Answer: This is the key challenge for this synthesis. Because 2,6-dichloropyridine has two electrophilic sites, diarylation is a highly competitive pathway. Selectivity is controlled by stoichiometry, reaction rate, and steric effects.

Potential Causes & Solutions:

- Stoichiometry and Reagent Addition:

- Expert Insight: Using an excess of the 2,6-dichloropyridine is the most straightforward way to favor mono-arylation. Once the first indoline is attached, the resulting product is generally less reactive than the starting dihalopyridine due to increased steric hindrance and altered electronics.
- Troubleshooting Steps:
 - Use a significant excess of 2,6-dichloropyridine (e.g., 2 to 4 equivalents). This statistically favors the reaction of indoline with the starting material over the mono-substituted product. The unreacted dichloropyridine can be removed later during workup or chromatography.
 - Consider slow addition of the indoline to the reaction mixture using a syringe pump. This keeps the concentration of the nucleophile low, further disfavoring the second substitution.
- Ligand Choice (for Buchwald-Hartwig):
 - Expert Insight: The ligand plays a crucial role in modulating the reactivity and steric environment of the palladium catalyst. Bulky ligands can enhance selectivity for mono-arylation.^[6] They can create a crowded catalytic center that makes the oxidative addition into the less-hindered C-Cl bond of the mono-substituted intermediate more difficult.
 - Troubleshooting Steps:
 - Switch to a bulkier phosphine ligand. If you are using a less bulky ligand like BINAP, consider trying XPhos, RuPhos, or BrettPhos, which are known to be effective for challenging couplings.^[1]
 - A screen of different ligands may be necessary to find the optimal balance for your specific conditions.
- Reaction Temperature and Time:
 - Expert Insight: Lowering the reaction temperature can sometimes increase selectivity by favoring the kinetically preferred mono-arylation over the thermodynamically more stable diarylation product, which may require a higher activation energy.

- Troubleshooting Steps:
 - Run the reaction at a lower temperature (e.g., 80 °C instead of 110 °C) and monitor carefully by TLC or LC-MS. Be aware that this will likely increase the required reaction time.
 - Stop the reaction as soon as the starting indoline is consumed to prevent further conversion to the di-substituted product.

Issue 3: Difficulty in Product Purification

Question: I have a mixture of products and starting materials that are difficult to separate by column chromatography. What can I do?

Answer: Co-elution of aromatic compounds with similar polarities is a frequent purification challenge.

Potential Causes & Solutions:

- Similar Polarity of Components:
 - Expert Insight: The starting 2,6-dichloropyridine, the desired mono-substituted product, and the di-substituted byproduct may have close R_f values on silica gel.
 - Troubleshooting Steps:
 - Optimize Chromatography: Use a shallow solvent gradient (e.g., starting with pure hexanes and slowly increasing the percentage of ethyl acetate). Using a non-polar aromatic solvent like toluene in the mobile phase (e.g., Hexane/Toluene/EtOAc) can sometimes improve the separation of aromatic compounds.
 - Acid/Base Wash: The product, **1-(6-chloro-2-pyridinyl)indoline**, has a basic pyridine nitrogen. You may be able to perform an acidic wash (e.g., with 1M HCl) to pull the product and any unreacted indoline into the aqueous phase, leaving non-basic impurities in the organic layer. Then, basify the aqueous layer (e.g., with NaOH) and re-extract the product. Caution: This may not work if starting materials are also basic.

- Recrystallization: If the product is a solid, recrystallization is an excellent method for purification.^[7] Try screening various solvents (e.g., ethanol, isopropanol, hexanes/ethyl acetate mixtures) to find one where the product is soluble at high temperature but sparingly soluble at room temperature or below.
- Persistent Catalyst/Ligand Impurities:
 - Expert Insight: Palladium residues and oxidized phosphine ligands can complicate purification.
 - Troubleshooting Steps:
 - Before concentrating the reaction mixture, filter it through a plug of Celite or silica gel to remove insoluble catalyst residues.^[1]
 - Stirring the crude product in a solvent like hexanes can often precipitate the product while leaving greasy ligand-related impurities in solution.

Frequently Asked Questions (FAQs)

Q1: Which method is better for this synthesis: Buchwald-Hartwig or Ullmann? Both methods are viable. The Buchwald-Hartwig amination is generally preferred in modern synthesis due to its milder reaction conditions (typically 80-110 °C), broader functional group tolerance, and the extensive availability of well-defined catalysts and ligands that allow for rational optimization. The traditional Ullmann condensation often requires harsher conditions (temperatures >140 °C) and stoichiometric amounts of copper, though modern ligand-accelerated versions have improved its scope.^{[2][5][8]} For initial attempts, a well-chosen Buchwald-Hartwig system is often the most reliable starting point.

Q2: How do I choose the right ligand and base for the Buchwald-Hartwig reaction? The choice is interdependent and substrate-specific. A good starting point is a combination of a bulky, electron-rich phosphine ligand like XPhos or RuPhos with a base like K₃PO₄ or Cs₂CO₃.^[1] This combination is often effective for N-arylation with heteroaryl chlorides. If yields are low, switching to a stronger base like NaOt-Bu may be beneficial, but be mindful of potential side reactions.

Q3: Can I use 2-bromo-6-chloropyridine instead of 2,6-dichloropyridine? Yes. In fact, this can be an excellent strategy to improve selectivity. In palladium-catalyzed cross-coupling, the oxidative addition step is generally faster for C-Br bonds than for C-Cl bonds. Therefore, the reaction will preferentially occur at the more reactive C-Br position, leading to a much cleaner mono-arylation.

Q4: How can I confirm the structure and purity of my final product? A combination of analytical techniques is essential:

- ^1H NMR: This is the primary tool for structural confirmation. You should expect to see characteristic signals for the indoline protons (triplets for the $-\text{CH}_2-\text{CH}_2-$ group) and the aromatic protons on both the indoline and pyridine rings.^[9] The integration of these signals should match the expected number of protons.
- ^{13}C NMR: Confirms the number of unique carbon atoms in the molecule.
- Mass Spectrometry (MS): Will confirm the molecular weight of the product. High-resolution mass spectrometry (HRMS) can confirm the elemental composition.
- TLC/LC-MS: These techniques are crucial for assessing purity and monitoring reaction progress. A pure product should appear as a single spot on a TLC plate or a single peak in an LC chromatogram.

Data Presentation: Comparison of Synthetic Routes

The following table provides a general comparison based on literature precedents for similar N-arylation reactions. Actual results may vary.

Parameter	Buchwald-Hartwig Amination	Ullmann Condensation
Catalyst	Palladium (e.g., Pd ₂ (dba) ₃ , Pd(OAc) ₂)	Copper (e.g., CuI, Cu ₂ O)
Typical Loading	1-5 mol%	5-20 mol% (can be stoichiometric)
Ligand	Bulky Phosphines (e.g., XPhos, BINAP)	Diamines, Phenanthrolines, Proline
Base	NaOt-Bu, K ₃ PO ₄ , Cs ₂ CO ₃	K ₂ CO ₃ , Cs ₂ CO ₃
Solvent	Toluene, Dioxane	DMF, NMP, Dioxane
Temperature	80 - 110 °C	120 - 180 °C
Typical Yield	60 - 95%	40 - 80%
Key Advantage	Milder conditions, broader scope	Lower cost catalyst
Key Disadvantage	Expensive catalyst/ligands	Harsh conditions, lower yields

Experimental Protocols

Safety Precaution: These reactions must be performed in a well-ventilated fume hood. Always wear appropriate personal protective equipment (PPE), including safety glasses, lab coat, and gloves. The reagents and solvents are flammable and/or toxic.

Protocol 1: Palladium-Catalyzed Buchwald-Hartwig Amination

This protocol is a general starting point and may require optimization.

Reagents:

- 2,6-Dichloropyridine (3.0 mmol, 1.0 equiv)
- Indoline (1.0 mmol, 0.33 equiv)

- Tris(dibenzylideneacetone)dipalladium(0) ($\text{Pd}_2(\text{dba})_3$) (0.02 mmol, 2 mol%)
- XPhos (2-Dicyclohexylphosphino-2',4',6'-triisopropylbiphenyl) (0.04 mmol, 4 mol%)
- Potassium Phosphate (K_3PO_4), finely ground (2.0 mmol, 2.0 equiv)
- Anhydrous, degassed toluene (10 mL)

Procedure:

- To a dry Schlenk flask equipped with a magnetic stir bar, add 2,6-dichloropyridine, $\text{Pd}_2(\text{dba})_3$, XPhos, and K_3PO_4 .
- Seal the flask with a septum, and evacuate and backfill with argon or nitrogen gas (repeat 3 times).
- Add the anhydrous, degassed toluene via syringe.
- Add the indoline via syringe.
- Place the flask in a preheated oil bath at 100 °C and stir vigorously.
- Monitor the reaction progress by TLC or LC-MS. The reaction is typically complete within 12-24 hours.
- Once complete, cool the reaction to room temperature. Dilute with ethyl acetate (20 mL) and filter through a pad of Celite to remove inorganic salts and catalyst residues.
- Wash the filtrate with water (2 x 15 mL) and then with brine (15 mL).
- Dry the organic layer over anhydrous sodium sulfate (Na_2SO_4), filter, and concentrate under reduced pressure.
- Purify the crude residue by flash column chromatography on silica gel (e.g., using a gradient of 5% to 20% ethyl acetate in hexanes) to afford the pure **1-(6-chloro-2-pyridinyl)indoline**.

Protocol 2: Copper-Catalyzed Ullmann Condensation

This protocol uses more classical, harsher conditions.

Reagents:

- 2,6-Dichloropyridine (3.0 mmol, 3.0 equiv)
- Indoline (1.0 mmol, 1.0 equiv)
- Copper(I) Iodide (CuI) (0.1 mmol, 10 mol%)
- L-Proline (0.2 mmol, 20 mol%)
- Cesium Carbonate (Cs₂CO₃) (2.0 mmol, 2.0 equiv)
- Anhydrous Dimethyl Sulfoxide (DMSO) (5 mL)

Procedure:

- To a dry Schlenk flask equipped with a magnetic stir bar, add 2,6-dichloropyridine, CuI, L-Proline, and Cs₂CO₃.
- Seal the flask, and evacuate and backfill with argon or nitrogen gas (repeat 3 times).
- Add anhydrous DMSO and indoline via syringe.
- Place the flask in a preheated oil bath at 130 °C and stir vigorously.
- Monitor the reaction progress by TLC or LC-MS (typically 24-48 hours).
- Cool the reaction to room temperature. Dilute with a large volume of water (50 mL) and extract with ethyl acetate (3 x 25 mL).
- Combine the organic layers and wash thoroughly with water (3 x 20 mL) to remove DMSO, followed by a brine wash (20 mL).
- Dry the organic layer over anhydrous Na₂SO₄, filter, and concentrate under reduced pressure.
- Purify the crude product by flash column chromatography as described in the Buchwald-Hartwig protocol.

Visualizations of Key Processes

Buchwald-Hartwig Catalytic Cycle

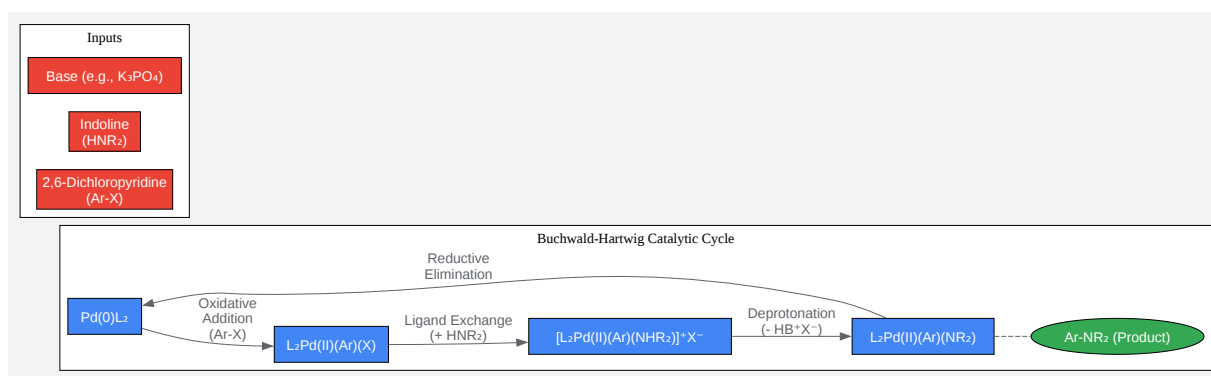

[Click to download full resolution via product page](#)

Caption: Simplified catalytic cycle for the Buchwald-Hartwig amination.

Experimental Workflow

[Click to download full resolution via product page](#)

Need Custom Synthesis?

BenchChem offers custom synthesis for rare earth carbides and specific isotopic labeling.

Email: info@benchchem.com or [Request Quote Online](#).

Sources

- [1. organic-synthesis.com](https://www.organic-synthesis.com) [[organic-synthesis.com](https://www.organic-synthesis.com)]
- [2. Ullmann Reaction](https://www.organic-chemistry.org) [[organic-chemistry.org](https://www.organic-chemistry.org)]
- [3. chem.libretexts.org](https://chem.libretexts.org) [chem.libretexts.org]
- [4. mdpi.com](https://www.mdpi.com) [[mdpi.com](https://www.mdpi.com)]
- [5. taylorandfrancis.com](https://www.taylorandfrancis.com) [[taylorandfrancis.com](https://www.taylorandfrancis.com)]
- [6. Nickel-Based Catalysts for the Selective Monoarylation of Dichloropyridines: Ligand Effects and Mechanistic Insights - PMC](https://pubmed.ncbi.nlm.nih.gov) [[pmc.ncbi.nlm.nih.gov](https://pubmed.ncbi.nlm.nih.gov)]
- [7. pdf.benchchem.com](https://www.pdf.benchchem.com) [[pdf.benchchem.com](https://www.pdf.benchchem.com)]
- [8. Ullmann coupling-An overview - operachem](https://www.operachem.com) [[operachem.com](https://www.operachem.com)]
- [9. Indoline\(496-15-1\) 1H NMR](https://www.m.chemicalbook.com) [[m.chemicalbook.com](https://www.m.chemicalbook.com)]
- To cite this document: BenchChem. [Technical Support Center: Synthesis of 1-(6-Chloro-2-pyridinyl)indoline]. BenchChem, [2026]. [Online PDF]. Available at: [<https://www.benchchem.com/product/b1392376/docs#technical-support-center-synthesis-of-1-6-chloro-2-pyridinyl-indoline>]

Disclaimer & Data Validity:

The information provided in this document is for Research Use Only (RUO) and is strictly not intended for diagnostic or therapeutic procedures. While BenchChem strives to provide accurate protocols, we make no warranties, express or implied, regarding the fitness of this product for every specific experimental setup.

Technical Support: The protocols provided are for reference purposes. Unsure if this reagent suits your experiment?

Need Industrial/Bulk Grade? [Request Custom Synthesis Quote](#)

BenchChem

Our mission is to be the trusted global source of essential and advanced chemicals, empowering scientists and researchers to drive progress in science and industry.

Contact

Address: 3281 E Guasti Rd

Ontario, CA 91761, United States

Phone: (601) 213-4426

Email: info@benchchem.com

[Contact our Ph.D. Support Team for a compatibility check](#)