

Application Note: Friedel-Crafts Acylation of 4-Picoline with Benzoyl Chloride

Author: BenchChem Technical Support Team. **Date:** May 2026

Compound of Interest

Compound Name: 3-Benzoyl-4-methylpyridine

CAS No.: 38824-77-0

Cat. No.: B1392142

[Get Quote](#)

Abstract: This application note provides a comprehensive technical guide for the Friedel-Crafts acylation of 4-picoline with benzoyl chloride. It details the mechanistic complexities, provides a robust experimental protocol, and addresses common challenges and troubleshooting. This document is intended for researchers, scientists, and drug development professionals engaged in organic synthesis, particularly those working with pyridine-based scaffolds. Due to the inherent challenges of acylating electron-deficient pyridine rings, this note emphasizes the critical parameters and alternative strategies necessary for a successful reaction.

Introduction: The Challenge of Pyridine Acylation

The Friedel-Crafts acylation is a fundamental and powerful tool for forming carbon-carbon bonds in the synthesis of aryl ketones.[1] However, its application to heteroaromatic compounds like pyridine and its derivatives, such as 4-picoline (4-methylpyridine), is notoriously difficult.[2] The primary obstacle is the pyridine nitrogen, which acts as a Lewis base and readily complexes with the Lewis acid catalyst (e.g., $AlCl_3$).[3] This complexation deactivates the aromatic ring toward electrophilic substitution, rendering the classical Friedel-Crafts reaction conditions ineffective.[2][3] Furthermore, the electronegative nitrogen atom inherently reduces the electron density of the ring, making it less nucleophilic than benzene.[2]

Despite these challenges, the synthesis of acylpyridines is of significant interest in medicinal chemistry and materials science. Therefore, modified procedures and alternative synthetic routes have been developed to overcome these limitations. This application note outlines a protocol tailored for the acylation of 4-picoline, a reaction that requires careful control of conditions to achieve the desired product, primarily 2-benzoyl-4-methylpyridine.

Overall Reaction:

Mechanistic Considerations

The acylation of 4-picoline proceeds via an electrophilic aromatic substitution pathway, though one that is significantly influenced by the pyridine nitrogen. The key mechanistic steps are as follows:

- **Generation of the Acylium Ion:** The Lewis acid catalyst, typically aluminum chloride (AlCl_3), reacts with benzoyl chloride to form a highly reactive acylium ion ($\text{C}_6\text{H}_5\text{CO}^+$).^{[4][5]} This electrophile is the key acylating species.
- **Electrophilic Attack:** The π -electron system of the 4-picoline ring attacks the acylium ion. The position of attack is directed by the interplay between the activating methyl group and the deactivating, directing influence of the nitrogen atom. Acylation typically occurs at the C-2 or C-3 position.
- **Deprotonation and Rearomatization:** A weak base, such as AlCl_4^- , removes a proton from the resulting cationic intermediate (a sigma complex), restoring the aromaticity of the pyridine ring to yield the final ketone product.^[4]

A critical aspect of this reaction is the stoichiometric requirement of the Lewis acid. The ketone product is also a Lewis base and will complex with AlCl_3 , effectively sequestering the catalyst.^{[6][7]} Therefore, at least a stoichiometric amount, and often an excess, of the Lewis acid is necessary to drive the reaction to completion.^[6]

Reaction Mechanism Workflow:

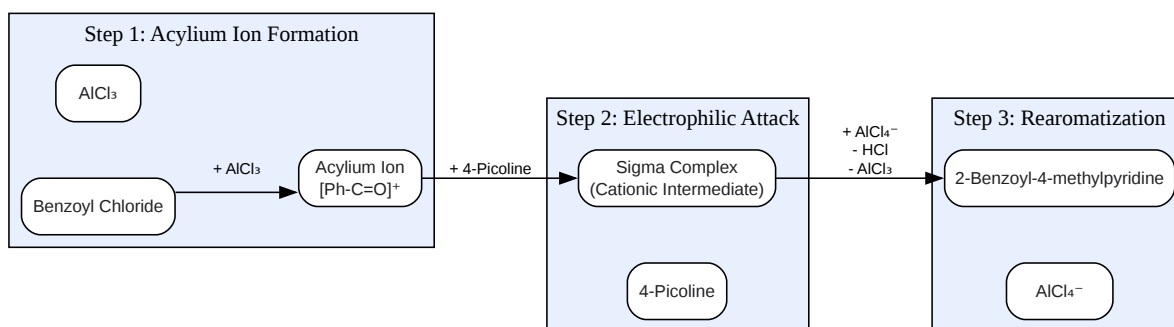

[Click to download full resolution via product page](#)

Figure 1: Key steps in the Friedel-Crafts acylation of 4-picoline.

Detailed Experimental Protocol

Safety Precautions: This protocol involves corrosive and moisture-sensitive reagents. All operations must be conducted in a well-ventilated fume hood. Appropriate personal protective equipment (PPE), including safety goggles, a lab coat, and chemical-resistant gloves, must be worn at all times.

3.1. Reagents and Equipment

Reagent/Material	Grade	Notes
4-Picoline	Anhydrous, $\geq 99\%$	Store under nitrogen and over molecular sieves.
Benzoyl Chloride	$\geq 99\%$, ReagentPlus®	Handle in a fume hood. Corrosive.
Aluminum Chloride (AlCl ₃)	Anhydrous, powder, $\geq 99.99\%$	Highly hygroscopic. Handle in a glovebox or under an inert atmosphere.
Dichloromethane (DCM)	Anhydrous, $\geq 99.8\%$	Use from a solvent purification system or freshly distilled.
Hydrochloric Acid (HCl)	Concentrated	For workup.
Sodium Hydroxide (NaOH)	50% aqueous solution	For pH adjustment during workup.
Chloroform	Reagent grade	For extraction.
Anhydrous Sodium Sulfate	Granular	For drying organic phases.

Equipment: Three-necked round-bottom flask, reflux condenser, dropping funnel, magnetic stirrer, nitrogen inlet, ice-salt bath.

3.2. Step-by-Step Procedure

- **Reaction Setup:** Assemble a flame-dried 500 mL three-necked round-bottom flask with a magnetic stir bar, a reflux condenser fitted with a calcium chloride drying tube, a dropping funnel, and a nitrogen inlet.
- **Reagent Charging:** Under a positive flow of nitrogen, add anhydrous benzene (250 mL) to the flask. Add anhydrous aluminum chloride (1.25 moles) in portions to the stirred solvent.
- **Formation of Nicotinoyl Chloride (In Situ):** In a separate flask, cautiously add thionyl chloride (3.5 moles) to 4-picoline (0.5 moles). Heat the mixture gently on a steam bath for one hour. Remove the excess thionyl chloride by distillation under reduced pressure. Add anhydrous benzene (100 mL) and distill to remove residual thionyl chloride.

- **Acylation Reaction:** Dissolve the crude nicotinoyl chloride in anhydrous benzene (250 mL) and add this solution to the dropping funnel. Cool the aluminum chloride suspension to 5-10 °C using an ice-salt bath. Add the nicotinoyl chloride solution dropwise to the AlCl_3 suspension over one hour, maintaining the internal temperature below 10 °C.
- **Reaction Completion:** After the addition is complete, remove the ice bath and allow the mixture to warm to room temperature. Heat the reaction mixture to reflux and maintain for 6 hours. The mixture will typically become dark red-brown.
- **Workup:** Cautiously pour the cooled reaction mixture onto a mixture of crushed ice (1 kg) and concentrated hydrochloric acid (100 mL). Separate and discard the organic layer. Extract the acidic aqueous layer with ether (3 x 250 mL) and discard the ether extracts.
- **Product Isolation:** Basify the aqueous solution with a 50% aqueous sodium hydroxide solution until the initially formed aluminum hydroxide redissolves. Cool the mixture and extract the product with chloroform (5 x 150 mL).
- **Purification:** Combine the chloroform extracts, wash with water, and dry over anhydrous sodium sulfate. Remove the solvent by distillation. The crude product is then purified by vacuum distillation.

Characterization Data

The primary product, 2-benzoyl-4-methylpyridine, should be characterized to confirm its identity and purity.

Analysis	Expected Results
Appearance	Yellowish oil or low-melting solid
Boiling Point	Approx. 141-145 °C at 4 mmHg[8]
¹ H NMR (CDCl ₃ , 500 MHz)	δ (ppm): ~8.6 (d, 1H), ~7.9-7.4 (m, 6H), ~7.2 (s, 1H), ~2.4 (s, 3H)
¹³ C NMR (CDCl ₃ , 125 MHz)	δ (ppm): ~194.5 (C=O), ~155.1, ~149.2, ~147.8, ~137.3, ~133.0, ~130.1, ~128.4, ~124.9, ~21.2 (CH ₃)
IR (ATR)	ν (cm ⁻¹): ~1670 (C=O stretch), ~1585, 1450 (aromatic C=C/C=N stretch)
Mass Spec (EI)	m/z: 197 [M] ⁺ , 105 [PhCO] ⁺ , 77 [Ph] ⁺

Troubleshooting Guide

Issue	Potential Cause(s)	Recommended Solution(s)
Low or No Reaction	Inactive catalyst due to moisture; Insufficient catalyst; Deactivated starting material.	Ensure all glassware is rigorously dried and use fresh anhydrous AlCl_3 . ^[7] Increase the molar ratio of AlCl_3 . Confirm the purity of 4-picoline.
Formation of Tarry Byproducts	Reaction temperature too high; Uncontrolled addition of reagents.	Maintain careful temperature control, especially during the initial addition of the acyl chloride. Ensure slow, dropwise addition.
Multiple Products Observed	Isomeric products (e.g., acylation at C-3); Side reactions.	Optimize reaction temperature to improve regioselectivity. Purification by column chromatography may be necessary to separate isomers.
Difficult Workup	Incomplete hydrolysis of the aluminum complexes.	Ensure vigorous stirring during the quenching step and add acid/base slowly to manage the exothermic reaction.

Conclusion

The Friedel-Crafts acylation of 4-picoline is a challenging but feasible transformation that provides access to valuable benzoylpyridine derivatives. Success hinges on the use of anhydrous conditions, a stoichiometric excess of a potent Lewis acid catalyst, and careful control over reaction temperature. The protocol and troubleshooting guide presented here offer a solid foundation for researchers to perform and optimize this reaction for their specific synthetic needs. While alternative methods involving pre-metalation of the pyridine ring or the use of more advanced catalytic systems exist, the modified Friedel-Crafts approach remains a relevant and cost-effective strategy.^[9]

References

- Selective, C-3 Friedel-Crafts acylation to generate functionally diverse, acetylated Imidazo[1,2-a]pyridine deriv
- BenchChem.
- Beyond Friedel–Crafts: Spontaneous and Fluoride-Catalyzed Acylation of 2-(Trialkylsilyl)pyridines. (2025).
- Preparation of Pyridines, Part 3: By Acyl
- C3-Alkylation of Imidazo[1,2-a]pyridines via Three-Component Aza-Friedel–Crafts Reaction Catalyzed by Y(OTf)₃. (2024). PubMed Central.
- Friedel-Crafts acylation reactions in pyridinium based ionic liquids. (2025).
- Why does Friedel-Crafts reaction with Pyridine fails, although Halogenation succeed, if both use a Lewis acid as a c
- friedel crafts acyl
- Friedel–Crafts reaction. Wikipedia.
- Friedel–Crafts Acyl
- EAS Reactions (3)
- Friedel-Crafts Acyl
- BenchChem.
- 2-Benzoylpyridine synthesis. ChemicalBook.
- Friedel-Crafts Acylation with Practice Problems. Chemistry Steps.
- Ch12: Friedel-Crafts limit
- Synthesis method of 2-(2-amino-5-bromo-benzoyl) pyridine.
- Synthesis method of 2-benzoylpyridine.
- 3-benzoylpyridine. Organic Syntheses Procedure.
- BenchChem.

Need Custom Synthesis?

BenchChem offers custom synthesis for rare earth carbides and specific isotopic labeling.

Email: info@benchchem.com or [Request Quote Online](#).

Sources

- [1. pdf.benchchem.com](https://pdf.benchchem.com) [pdf.benchchem.com]
- [2. brainly.in](https://brainly.in) [brainly.in]
- [3. quora.com](https://quora.com) [quora.com]
- [4. masterorganicchemistry.com](https://masterorganicchemistry.com) [masterorganicchemistry.com]

- [5. Friedel-Crafts Acylation with Practice Problems - Chemistry Steps \[chemistrysteps.com\]](#)
- [6. Friedel–Crafts reaction - Wikipedia \[en.wikipedia.org\]](#)
- [7. pdf.benchchem.com \[pdf.benchchem.com\]](#)
- [8. Organic Syntheses Procedure \[orgsyn.org\]](#)
- [9. Selective, C-3 Friedel-Crafts acylation to generate functionally diverse, acetylated Imidazo\[1,2-a\]pyridine derivatives - PMC \[pmc.ncbi.nlm.nih.gov\]](#)
- To cite this document: BenchChem. [Application Note: Friedel-Crafts Acylation of 4-Picoline with Benzoyl Chloride]. BenchChem, [2026]. [Online PDF]. Available at: [\[https://www.benchchem.com/product/b1392142/docs#application-note-friedel-crafts-acylation-of-4-picoline-with-benzoyl-chloride\]](https://www.benchchem.com/product/b1392142/docs#application-note-friedel-crafts-acylation-of-4-picoline-with-benzoyl-chloride)

Disclaimer & Data Validity:

The information provided in this document is for Research Use Only (RUO) and is strictly not intended for diagnostic or therapeutic procedures. While BenchChem strives to provide accurate protocols, we make no warranties, express or implied, regarding the fitness of this product for every specific experimental setup.

Technical Support: The protocols provided are for reference purposes. Unsure if this reagent suits your experiment?

Need Industrial/Bulk Grade? [Request Custom Synthesis Quote](#)

BenchChem

Our mission is to be the trusted global source of essential and advanced chemicals, empowering scientists and researchers to drive progress in science and industry.

Contact

Address: 3281 E Guasti Rd

Ontario, CA 91761, United States

Phone: (601) 213-4426

Email: info@benchchem.com

Contact our Ph.D. Support Team for a compatibility check