

A Comparative Guide to the Structural Elucidation of a Novel Oxazole Derivative

Author: BenchChem Technical Support Team. **Date:** May 2026

Compound of Interest

Compound Name:	2-Bromo-1,3-oxazole hydrochloride
CAS No.:	1305712-69-9
Cat. No.:	B1392803

[Get Quote](#)

In the realm of drug discovery and materials science, the synthesis of novel heterocyclic compounds, such as oxazole derivatives, represents a significant step forward. However, the initial synthesis is merely the prologue to a critical chapter: the unambiguous confirmation of the molecule's structure. This guide provides an in-depth comparison of the essential analytical techniques employed to elucidate the structure of a novel oxazole derivative. We will delve into the causality behind experimental choices, presenting a self-validating system of protocols that ensures scientific rigor.

The structural confirmation of a new molecule is a puzzle where each analytical technique provides a unique set of clues. Relying on a single method is fraught with peril; instead, a multi-pronged approach, where data from different experiments corroborate one another, is the gold standard. This guide will explore the synergistic interplay of Mass Spectrometry, NMR Spectroscopy, FTIR Spectroscopy, and Single-Crystal X-ray Crystallography.

The Strategic Workflow for Structural Confirmation

The process of elucidating the structure of a novel compound follows a logical progression. Initially, we seek to determine the molecular formula. Subsequently, we identify the functional groups present and piece together the connectivity of the atoms. Finally, for an unequivocal confirmation of the three-dimensional arrangement, a crystallographic study is often the ultimate arbiter.

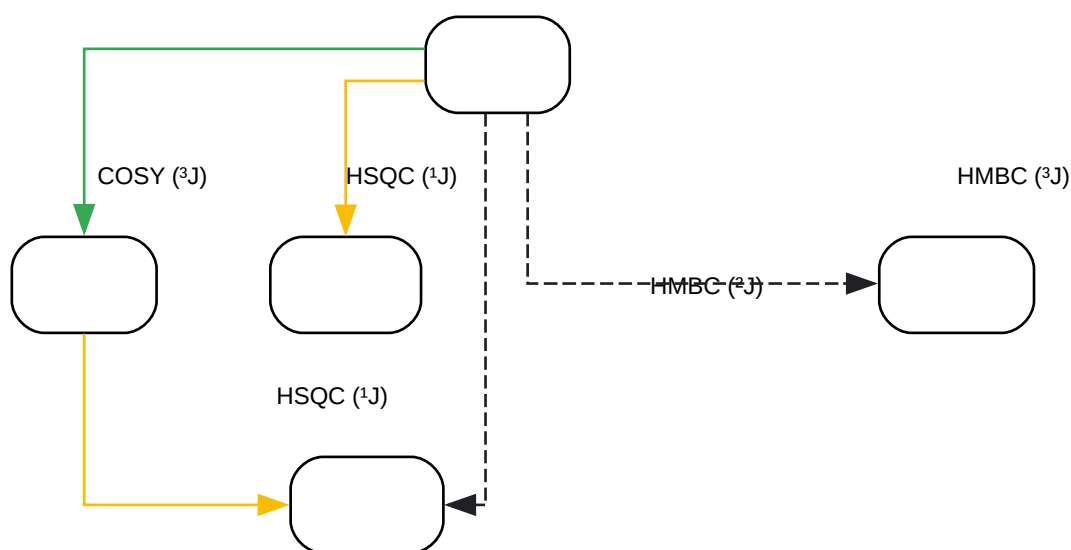
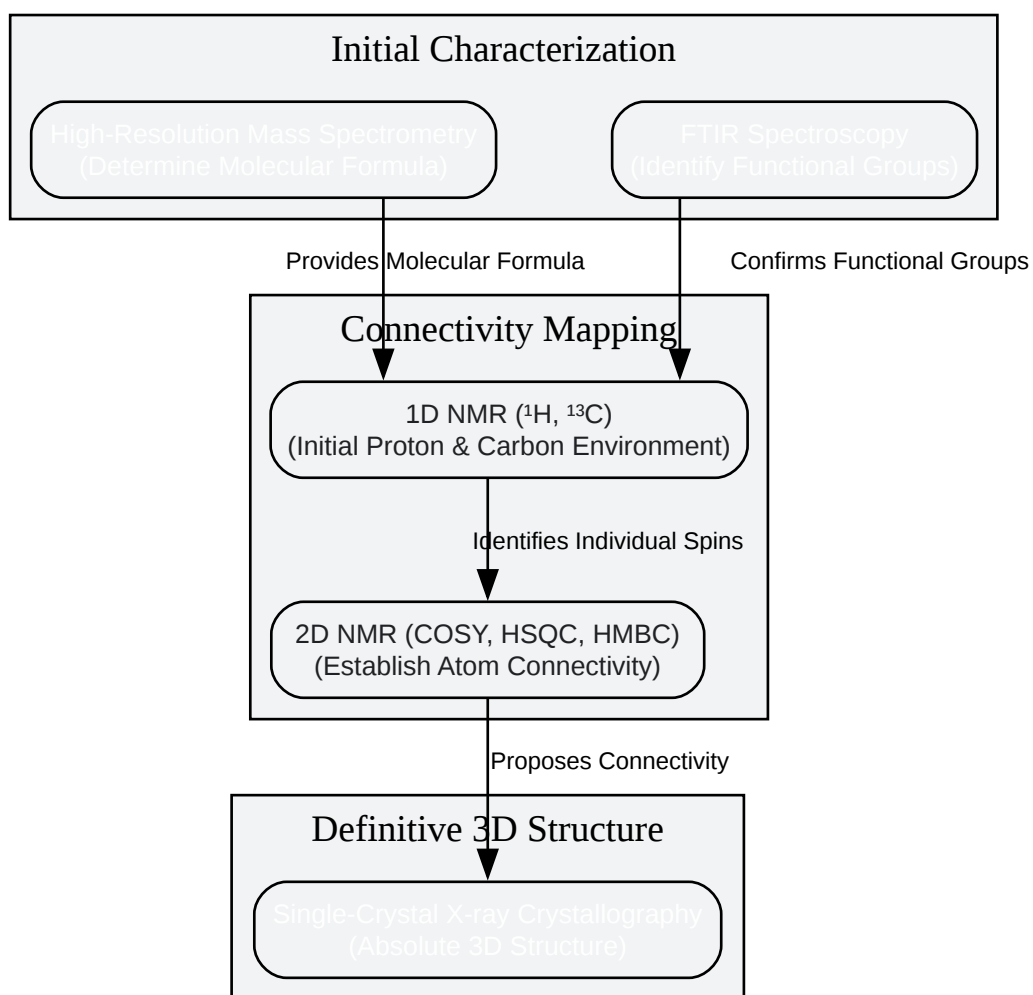

[Click to download full resolution via product page](#)

Caption: Relationship between different 2D NMR experiments for determining connectivity.

Experimental Protocol: Comprehensive NMR Analysis

- **Sample Preparation:** Dissolve 5-10 mg of the purified oxazole derivative in 0.5-0.7 mL of a deuterated solvent (e.g., CDCl_3 , DMSO-d_6). Add a small amount of tetramethylsilane (TMS) as an internal standard (0 ppm).
- **^1H NMR Acquisition:** Acquire a standard ^1H NMR spectrum. Optimize parameters such as the number of scans and relaxation delay.
- **^{13}C NMR Acquisition:** Acquire a proton-decoupled ^{13}C NMR spectrum. This may require a longer acquisition time due to the lower natural abundance and sensitivity of the ^{13}C nucleus.
- **2D NMR Acquisition:**
 - **COSY:** Acquire a gradient-selected COSY spectrum.
 - **HSQC:** Acquire a gradient-selected HSQC spectrum, optimized for one-bond C-H coupling constants (typically ~ 145 Hz).
 - **HMBC:** Acquire a gradient-selected HMBC spectrum, optimized for long-range C-H coupling constants (typically 4-8 Hz).
- **Data Analysis:** Process and analyze all spectra. Use the ^1H and ^{13}C spectra to identify the basic spin systems. Use the COSY spectrum to connect protons within a spin system. Use the HSQC spectrum to assign protons to their directly attached carbons. Use the HMBC spectrum to piece together the molecular fragments and confirm the overall connectivity, including the substitution pattern on the oxazole ring.

Fourier-Transform Infrared (FTIR) Spectroscopy: Identifying Functional Groups

FTIR spectroscopy is a rapid and non-destructive technique that provides information about the functional groups present in a molecule. [1][2] It works by measuring the absorption of infrared radiation by the sample, which causes molecular vibrations at specific frequencies. [3]

Causality of Choice: Different functional groups have characteristic absorption frequencies. For an oxazole derivative, one would expect to see characteristic peaks for C=N and C-O

stretching vibrations within the heterocyclic ring, as well as peaks corresponding to any substituents. [4]

Comparison of FTIR Data for Different Functional Groups

Functional Group	Typical Wavenumber (cm ⁻¹)	Vibration Type
C=N (in oxazole)	1600 - 1650	Stretching
C-O (in oxazole)	1020 - 1250	Stretching
Aromatic C=C	1450 - 1600	Stretching
C-H (aromatic)	3000 - 3100	Stretching
C-H (aliphatic)	2850 - 3000	Stretching
C=O (carbonyl)	1650 - 1800	Stretching

Experimental Protocol: FTIR Spectroscopy (Attenuated Total Reflectance - ATR)

- Background Scan: Record a background spectrum of the clean ATR crystal.
- Sample Application: Place a small amount of the solid or liquid sample directly onto the ATR crystal.
- Sample Scan: Acquire the infrared spectrum of the sample.
- Data Analysis: Identify the characteristic absorption bands and correlate them with specific functional groups.

Single-Crystal X-ray Crystallography: The Definitive 3D Structure

While spectroscopic methods provide powerful evidence for the structure of a molecule, single-crystal X-ray crystallography is considered the gold standard for the unambiguous

determination of the three-dimensional arrangement of atoms in a molecule. [5][6][7] This technique provides precise information about bond lengths, bond angles, and stereochemistry. [8] Causality of Choice: When a well-ordered single crystal is irradiated with X-rays, the X-rays are diffracted in a specific pattern that is dependent on the arrangement of atoms in the crystal lattice. [9] By analyzing this diffraction pattern, the electron density map of the molecule can be reconstructed, revealing the precise location of each atom.

Comparison with Spectroscopic Methods

Technique	Information Provided	Sample Requirement	Ambiguity
NMR Spectroscopy	Connectivity, relative stereochemistry	Soluble	Can be ambiguous for complex structures
Mass Spectrometry	Molecular formula, fragmentation	Ionizable	Does not provide connectivity information
FTIR Spectroscopy	Functional groups	IR active	Does not provide connectivity information
X-ray Crystallography	Absolute 3D structure, bond lengths, bond angles	Single crystal	Unambiguous (if a suitable crystal is obtained)

Experimental Protocol: Single-Crystal X-ray Diffraction

- **Crystal Growth:** Grow a single crystal of the oxazole derivative of suitable size and quality. This is often the most challenging step and may require screening of various solvents and crystallization conditions.
- **Crystal Mounting:** Mount a suitable crystal on a goniometer head.
- **Data Collection:** Place the crystal in a diffractometer and collect the diffraction data by rotating the crystal in the X-ray beam.

- **Structure Solution and Refinement:** Process the diffraction data to solve the crystal structure. This involves determining the phases of the diffracted X-rays and generating an electron density map. Refine the atomic positions and thermal parameters to obtain the final structure.
- **Data Analysis:** Analyze the final structure to determine bond lengths, bond angles, and other geometric parameters.

Conclusion

The structural elucidation of a novel oxazole derivative is a systematic process that relies on the convergence of evidence from multiple analytical techniques. High-Resolution Mass Spectrometry provides the molecular formula, laying the foundation for further investigation. A comprehensive suite of 1D and 2D NMR experiments then allows for the detailed mapping of the atomic connectivity. FTIR spectroscopy offers a rapid means of confirming the presence of key functional groups. Finally, single-crystal X-ray crystallography stands as the ultimate arbiter, providing an unambiguous three-dimensional picture of the molecule. By judiciously applying these techniques in a logical workflow, researchers can confidently and accurately confirm the structure of their newly synthesized compounds, paving the way for further research and development.

References

- Advanced NMR techniques for structural characterization of heterocyclic structures - ESA-IPB. (n.d.). Retrieved January 26, 2026, from [\[Link\]](#)
- The high-resolution mass spectrometry (HRMS) analyses for the identification of the possible Ru species. (n.d.). ResearchGate. Retrieved January 26, 2026, from [\[Link\]](#)
- Synthesis and Spectroscopic Studies of Some New Oxazole Derivatives Dyes. (2014). International Journal of Pharmaceutical Sciences Review and Research, 26(2), 163-169.
- a FTIR spectrum of α -oxazolyl-functionalized polystyrene (3):... (n.d.). ResearchGate. Retrieved January 26, 2026, from [\[Link\]](#)
- Determination of the Molecular Formula by High Resolution Mass Spectrometry. (2020, May 30). Chemistry LibreTexts. Retrieved January 26, 2026, from [\[Link\]](#)

- Synthesis and Spectroscopic Studies of Some New Oxazole Derivatives Dyes. (2014). International Journal of Pharmaceutical Sciences Review and Research, 26(2), 163-169.
- HRMS: Fundamentals and Basic Concepts. (n.d.). In High-Resolution Mass Spectrometry (HRMS) in Food Analysis. Retrieved January 26, 2026, from [[Link](#)]
- Exploring The Synthesis And Characterization Of Novel Oxazole Derivatives And Its Biological Activity. (n.d.). Journal of Pharmaceutical Negative Results. Retrieved January 26, 2026, from [[Link](#)]
- Identification of metabolites from 2D 1H-13C HSQC NMR using peak correlation plots. (n.d.). DiVA. Retrieved January 26, 2026, from [[Link](#)]
- Formula determination by high resolution mass spectrometry. (2019, March 18). YouTube. Retrieved January 26, 2026, from [[Link](#)]
- Determination of Absolute Configuration Using Single Crystal X-Ray Diffraction. (n.d.). ResearchGate. Retrieved January 26, 2026, from [[Link](#)]
- Functional group profiling of medicinal plants using FTIR spectroscopy. (2023). World Journal of Biology Pharmacy and Health Sciences, 13(1), 045-052.
- 2D NMR Spectroscopy: COSY, HSQC (HMQC) and HMBC. (2020, August 10). YouTube. Retrieved January 26, 2026, from [[Link](#)]
- How to Interpret FTIR Results: A Beginner's Guide. (2024, March 21). AZoM.com. Retrieved January 26, 2026, from [[Link](#)]
- Combination of 1H and 13C NMR Spectroscopy. (n.d.). In NMR Spectra of Polymers and Pyrolysis Products. Retrieved January 26, 2026, from [[Link](#)]
- Structure elucidation – Knowledge and References. (n.d.). Taylor & Francis. Retrieved January 26, 2026, from [[Link](#)]
- Synthesis and Spectroscopic Studies of Some New Oxazole Derivatives Dyes. (2014). Semantic Scholar. Retrieved January 26, 2026, from [[Link](#)]

- Determination of functional groups and identification of compounds by using IR Spectroscopy. (2021, April 2). YouTube. Retrieved January 26, 2026, from [\[Link\]](#)
- Supporting Information. (n.d.). ScienceOpen. Retrieved January 26, 2026, from [\[Link\]](#)
- Small molecule crystallography. (n.d.). Excillum. Retrieved January 26, 2026, from [\[Link\]](#)
- Methods for the Elucidation of the Structure of Organic Compounds. (n.d.). MIT OpenCourseWare. Retrieved January 26, 2026, from [\[Link\]](#)
- High-Resolution Mass Spectrometry Definition. (n.d.). Fiveable. Retrieved January 26, 2026, from [\[Link\]](#)
- Heterocyclic Oxadiazole Derivatives Through Various Spectroscopic Techniques as UV, IR. (n.d.). JournalsPub. Retrieved January 26, 2026, from [\[Link\]](#)
- Structure Elucidation of Organic Compounds. (2023, June 9). YouTube. Retrieved January 26, 2026, from [\[Link\]](#)
- Single Crystal X-ray Structure Analysis. (n.d.). In Comprehensive Coordination Chemistry III. Retrieved January 26, 2026, from [\[Link\]](#)
- Functional Group Identification for FTIR Spectra Using Image-Based Machine Learning Models. (2021). Semantic Scholar. Retrieved January 26, 2026, from [\[Link\]](#)
- Structural Elucidation Of Unknown Organic Compound A Using Physical, Chemical And Spectroscopic Methods. (n.d.). University of Nairobi. Retrieved January 26, 2026, from [\[Link\]](#)
- Determination of crystal structure by single crystal X-ray diffraction. (n.d.). University of Aveiro. Retrieved January 26, 2026, from [\[Link\]](#)
- Natural Products Chemistry: Advances in Synthetic, Analytical and Bioactivity Studies, Volume II. (n.d.). MDPI. Retrieved January 26, 2026, from [\[Link\]](#)

Need Custom Synthesis?

BenchChem offers custom synthesis for rare earth carbides and specific isotopic labeling.

Email: info@benchchem.com or [Request Quote Online](#).

Sources

- [1. wjbphs.com \[wjbphs.com\]](#)
- [2. m.youtube.com \[m.youtube.com\]](#)
- [3. azooptics.com \[azooptics.com\]](#)
- [4. journalspub.com \[journalspub.com\]](#)
- [5. rigaku.com \[rigaku.com\]](#)
- [6. excillum.com \[excillum.com\]](#)
- [7. books.rsc.org \[books.rsc.org\]](#)
- [8. researchgate.net \[researchgate.net\]](#)
- [9. fenix.ciencias.ulisboa.pt \[fenix.ciencias.ulisboa.pt\]](#)
- To cite this document: BenchChem. [A Comparative Guide to the Structural Elucidation of a Novel Oxazole Derivative]. BenchChem, [2026]. [Online PDF]. Available at: [\[https://www.benchchem.com/product/b1392803/docs#a-comparative-guide-to-the-structural-elucidation-of-a-novel-oxazole-derivative\]](https://www.benchchem.com/product/b1392803/docs#a-comparative-guide-to-the-structural-elucidation-of-a-novel-oxazole-derivative)

Disclaimer & Data Validity:

The information provided in this document is for Research Use Only (RUO) and is strictly not intended for diagnostic or therapeutic procedures. While BenchChem strives to provide accurate protocols, we make no warranties, express or implied, regarding the fitness of this product for every specific experimental setup.

Technical Support: The protocols provided are for reference purposes. Unsure if this reagent suits your experiment?

Need Industrial/Bulk Grade? [Request Custom Synthesis Quote](#)

BenchChem

Our mission is to be the trusted global source of essential and advanced chemicals, empowering scientists and researchers to drive progress in science and industry.

Contact

Address: 3281 E Guasti Rd

Ontario, CA 91761, United States

Phone: (601) 213-4426

Email: info@benchchem.com

[Contact our Ph.D. Support Team for a compatibility check](#)