

# Technical Guide: Structure Elucidation of (4S)-4-(4-Methoxybenzyl)-L-glutamic acid

**Author:** BenchChem Technical Support Team. **Date:** April 2026

## Compound of Interest

Compound Name: (4S)-4-(4-Methoxybenzyl)-L-glutamic acid

Cat. No.: B13918817

[Get Quote](#)

## Introduction

**(4S)-4-(4-Methoxybenzyl)-L-glutamic acid** is a synthetic amino acid derivative with potential applications in medicinal chemistry and drug development. As a substituted analog of glutamic acid, a key neurotransmitter, this compound and its stereoisomers are of significant interest for exploring structure-activity relationships in various biological targets.<sup>[1][2][3]</sup> The precise determination of its three-dimensional structure, including the absolute configuration at its two chiral centers (C2 and C4), is paramount for understanding its biological activity and ensuring the synthesis of enantiomerically pure compounds for pharmacological evaluation.

This in-depth technical guide provides a comprehensive workflow for the complete structure elucidation of **(4S)-4-(4-Methoxybenzyl)-L-glutamic acid**. It is designed for researchers, scientists, and drug development professionals, offering not just a series of protocols, but a logical framework grounded in the principles of spectroscopic analysis and chiral separation. We will delve into the "why" behind each experimental choice, ensuring a thorough understanding of the data generated and its interpretation.

## Foundational Analysis: Confirming Connectivity and Molecular Formula

The initial step in the structure elucidation of a novel compound is to confirm its elemental composition and the connectivity of its atoms. High-resolution mass spectrometry (HRMS) and a suite of one- and two-dimensional Nuclear Magnetic Resonance (NMR) experiments are the cornerstones of this foundational analysis.

### High-Resolution Mass Spectrometry (HRMS)

**Expertise & Experience:** HRMS provides an extremely accurate mass measurement of the parent ion, allowing for the unambiguous determination of the molecular formula. This is the first and most critical piece of data to validate the successful synthesis of the target molecule. For a compound like **(4S)-4-(4-Methoxybenzyl)-L-glutamic acid**, electrospray ionization (ESI) in positive ion mode is typically the method of choice due to the presence of the basic amino group.

#### Experimental Protocol: HRMS Analysis

- **Sample Preparation:** Dissolve a small amount (approx. 1 mg) of the synthesized compound in a suitable solvent system, such as a 1:1 mixture of water and acetonitrile with 0.1% formic acid, to a final concentration of 10-20 pmol/μL.[4]
- **Instrumentation:** Utilize a high-resolution mass spectrometer, such as a time-of-flight (TOF) or Orbitrap instrument, equipped with an ESI source.
- **Data Acquisition:** Infuse the sample solution directly into the mass spectrometer. Acquire the mass spectrum in positive ion mode over a relevant m/z range.
- **Data Analysis:** Identify the protonated molecular ion  $[M+H]^+$ . Compare the experimentally measured accurate mass to the theoretical mass calculated for the proposed molecular formula (C<sub>13</sub>H<sub>17</sub>NO<sub>5</sub>). The mass difference should be within a few parts per million (ppm) to confirm the elemental composition.

### Nuclear Magnetic Resonance (NMR) Spectroscopy

Expertise & Experience: NMR spectroscopy is the most powerful technique for determining the carbon-hydrogen framework of an organic molecule. A combination of 1D ( $^1\text{H}$ ,  $^{13}\text{C}$ ) and 2D (COSY, HSQC, HMBC) experiments provides a complete picture of the atomic connectivity.

## Experimental Protocol: NMR Analysis

- **Sample Preparation:** Dissolve approximately 5-10 mg of the compound in a suitable deuterated solvent (e.g.,  $\text{D}_2\text{O}$  or  $\text{DMSO-d}_6$ ). The choice of solvent is critical to avoid exchange of labile protons (e.g.,  $-\text{NH}_3^+$ ,  $-\text{COOH}$ ) and to ensure good signal resolution.
- **Instrumentation:** Use a high-field NMR spectrometer (e.g., 400 MHz or higher) for optimal signal dispersion and sensitivity.
- **Data Acquisition:**
  - $^1\text{H}$  NMR: Acquire a standard one-dimensional proton spectrum to identify the different types of protons and their relative integrations.
  - $^{13}\text{C}$  NMR: Acquire a proton-decoupled carbon spectrum to identify all unique carbon atoms in the molecule.
  - COSY (Correlation Spectroscopy): This 2D experiment reveals proton-proton ( $^1\text{H}$ - $^1\text{H}$ ) spin-spin coupling networks, allowing for the identification of adjacent protons.
  - HSQC (Heteronuclear Single Quantum Coherence): This 2D experiment correlates directly bonded proton and carbon atoms ( $^1\text{H}$ - $^{13}\text{C}$ ), enabling the assignment of proton signals to their corresponding carbon atoms.
  - HMBC (Heteronuclear Multiple Bond Correlation): This 2D experiment shows correlations between protons and carbons that are two or three bonds away, which is crucial for piecing together the molecular fragments and confirming the overall structure.

## Data Interpretation and Expected Results

The combined analysis of these NMR spectra should allow for the unambiguous assignment of all proton and carbon signals, confirming the glutamic acid backbone, the presence and position of the 4-methoxybenzyl substituent, and the two carboxylic acid groups.

Table 1: Expected  $^1\text{H}$  and  $^{13}\text{C}$  NMR Chemical Shift Ranges for **(4S)-4-(4-Methoxybenzyl)-L-glutamic acid**

Atom	Expected $^1\text{H}$ Chemical Shift (ppm)	Expected $^{13}\text{C}$ Chemical Shift (ppm)
H-2 ( $\alpha$ -H)	3.5 - 4.0	50 - 55
H-3	1.8 - 2.2	30 - 35
H-4	2.5 - 3.0	40 - 45
Benzyl $\text{CH}_2$	2.8 - 3.2	35 - 40
Aromatic CH	6.8 - 7.2	114 - 130
Methoxy $\text{OCH}_3$	3.7 - 3.9	55 - 60
C-1 ( $\alpha$ -COOH)	-	175 - 180
C-5 ( $\gamma$ -COOH)	-	178 - 183
Aromatic C- $\text{OCH}_3$	-	158 - 162
Aromatic C- $\text{CH}_2$	-	130 - 135

Visualization of NMR Correlation Workflow

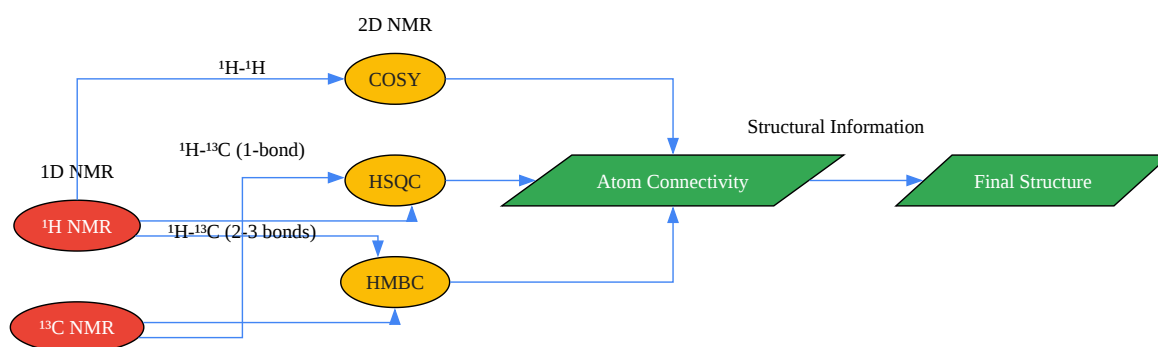

[Click to download full resolution via product page](#)

Caption: Workflow for determining molecular connectivity using NMR spectroscopy.

## Stereochemical Assignment: Unraveling the 3D Architecture

With the connectivity established, the next critical phase is to determine the absolute configuration at the two stereocenters, C2 (the  $\alpha$ -carbon of the glutamic acid) and C4. This requires specialized analytical techniques that are sensitive to the spatial arrangement of atoms.

## Chiral High-Performance Liquid Chromatography (HPLC)

Expertise & Experience: Chiral HPLC is a powerful and widely used technique for separating enantiomers and diastereomers.[5][6][7][8][9] The choice of the chiral stationary phase (CSP) is paramount for achieving successful separation. For amino acids and their derivatives, polysaccharide-based and macrocyclic glycopeptide-based CSPs are often effective.[5][8] By

comparing the retention time of the synthesized compound to that of authentic, stereochemically defined standards, the absolute configuration can be determined.

## Experimental Protocol: Chiral HPLC Analysis

- Column Selection:
  - Initial Screening: Screen a variety of chiral columns, such as those with cellulose or amylose-based CSPs (e.g., Lux Cellulose-1, Chiralcel OD) and macrocyclic glycopeptide CSPs (e.g., Chirobiotic T).[5][8]
  - Rationale: Polysaccharide-based CSPs are versatile for a wide range of chiral compounds, while macrocyclic glycopeptides are particularly well-suited for polar and ionic analytes like amino acids.[5]
- Mobile Phase Optimization:
  - Reversed-Phase: Start with a mobile phase of acetonitrile/water or methanol/water with an acidic modifier like trifluoroacetic acid (TFA) or formic acid.[8]
  - Normal-Phase: If reversed-phase is unsuccessful, explore normal-phase conditions using hexane/isopropanol mixtures.
  - Ion-Pairing: For zwitterionic compounds, the addition of an ion-pairing reagent can improve peak shape and resolution.[6]
- Analysis:
  - Inject a solution of the synthesized compound and compare its retention time to those of the four possible stereoisomers ((2S,4S), (2R,4R), (2S,4R), and (2R,4S)), if available as standards.
  - If standards are not available, this method can confirm the diastereomeric and enantiomeric purity of the synthesized material.

## Advanced NMR Techniques for Stereochemical Analysis

Expertise & Experience: While standard NMR confirms connectivity, more advanced techniques can provide insights into the relative and absolute stereochemistry.

- Nuclear Overhauser Effect (NOE) Spectroscopy (NOESY/ROESY): These experiments detect protons that are close in space (typically  $< 5 \text{ \AA}$ ). For a cyclic or conformationally restricted molecule, the presence or absence of NOE cross-peaks between specific protons can help determine their relative stereochemistry. For a flexible molecule like **(4S)-4-(4-Methoxybenzyl)-L-glutamic acid**, this may be less definitive but can still provide valuable clues.
- Chiral Derivatizing Agents (CDAs): Reacting the amino acid with a chiral agent, such as Mosher's acid chloride (MTPA-Cl), creates diastereomeric derivatives that can often be distinguished by NMR.<sup>[10]</sup> The differences in the chemical shifts of protons near the newly formed chiral center can be used to deduce the absolute configuration of the original amino acid.<sup>[10]</sup>
- Chiral Solvating Agents (CSAs): The use of a chiral solvent can induce small chemical shift differences between enantiomers, allowing for their differentiation and quantification by NMR.

### Experimental Protocol: Stereochemical Analysis using a Chiral Derivatizing Agent (e.g., (R)- and (S)-MTPA-Cl)

- Derivatization: React two separate aliquots of the synthesized amino acid with (R)-MTPA-Cl and (S)-MTPA-Cl, respectively, to form the corresponding diastereomeric amides.
- $^1\text{H}$  NMR Analysis: Acquire high-resolution  $^1\text{H}$  NMR spectra for both diastereomeric products.
- Data Interpretation: Carefully compare the chemical shifts of the protons in the two spectra, particularly those on the glutamic acid backbone. The differences in chemical shifts ( $\Delta\delta = \delta\text{S} - \delta\text{R}$ ) can be used to construct a model that allows for the assignment of the absolute configuration at the C2 center.

## Tandem Mass Spectrometry (MS/MS) for Structural Confirmation

Expertise & Experience: Tandem mass spectrometry (MS/MS) provides further structural confirmation by fragmenting the parent ion and analyzing the resulting daughter ions. The fragmentation pattern is characteristic of the molecule's structure and can be used to confirm the presence of key functional groups and their connectivity.

## Experimental Protocol: MS/MS Analysis

- Instrumentation: Use a mass spectrometer capable of tandem MS, such as a triple quadrupole, ion trap, or Q-TOF instrument.
- Data Acquisition:
  - Select the protonated molecular ion  $[M+H]^+$  as the precursor ion.
  - Induce fragmentation using collision-induced dissociation (CID).
  - Acquire the product ion spectrum.
- Data Interpretation:
  - Analyze the fragmentation pattern. For glutamic acid derivatives, characteristic losses include water ( $H_2O$ ), ammonia ( $NH_3$ ), and carbon monoxide ( $CO$ ) from the carboxylic acid groups.[\[11\]](#)
  - The fragmentation of the 4-methoxybenzyl side chain will also produce characteristic ions.
  - Compare the observed fragmentation pattern to that of known glutamic acid derivatives to confirm the structural assignments.[\[11\]](#)[\[12\]](#)[\[13\]](#)

## Visualization of the Overall Structure Elucidation Strategy

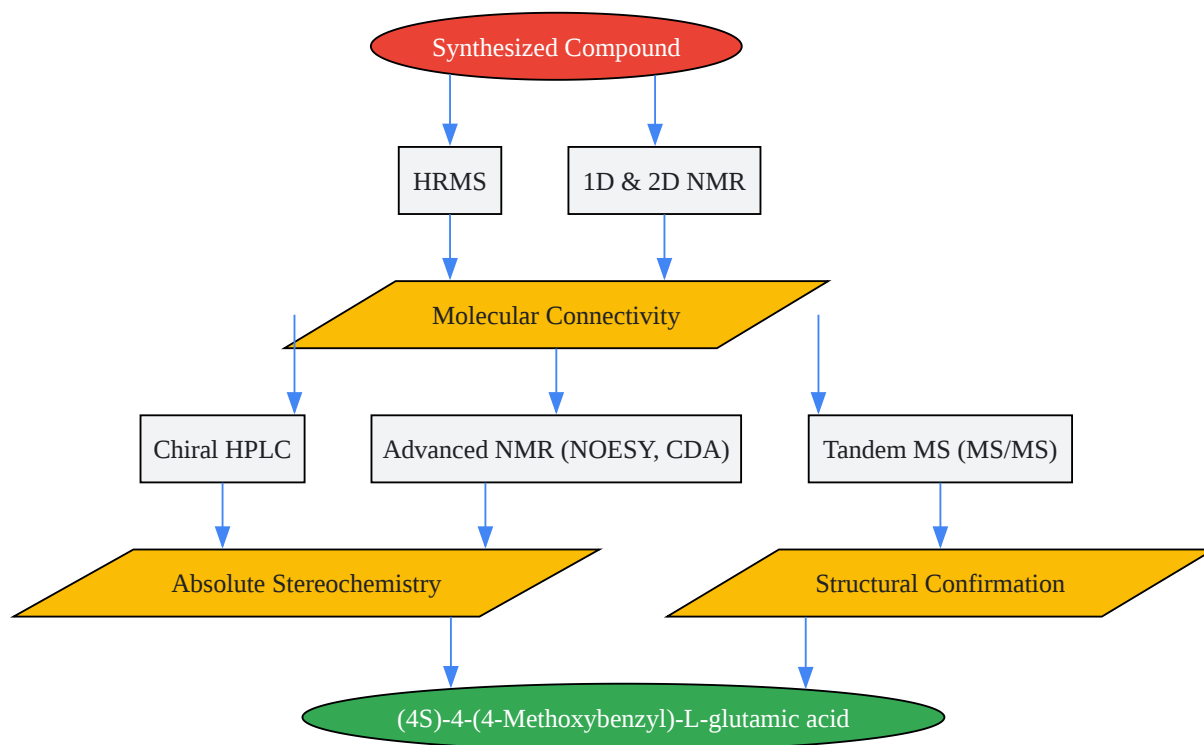

[Click to download full resolution via product page](#)

Caption: A comprehensive workflow for the structure elucidation of a novel compound.

## Conclusion

The rigorous and systematic application of the analytical techniques outlined in this guide will enable the unambiguous structure elucidation of **(4S)-4-(4-Methoxybenzyl)-L-glutamic acid**. This multi-faceted approach, combining high-resolution mass spectrometry, a suite of NMR experiments, and chiral separation techniques, ensures the highest level of scientific integrity and provides the foundational data necessary for advancing this compound in drug discovery and development programs. Each step in this workflow is designed to be self-validating, providing a robust and reliable pathway to a complete and accurate structural assignment.

## References

- Ovchinnikova, T. V., et al. (2018). Chiral Chromatographic Analysis of Amino Acids with Pre-column Derivatization by o-Phthalaldehyde: Improving the Determination of Enantiomers Using Ion-Pair Reagents. *Acta Naturae*, 10(4), 85-93. [[Link](#)]
- Phenomenex. HPLC Enantioseparation of N-FMOC  $\alpha$ -Amino Acids Using Lux Polysaccharide-Based Chiral Stationary Phases. [[Link](#)]
- Esquivel, B., et al. (1998). Chiral HPLC Separation of Protected Amino Acids.
- Harrison, A. G. (2003). Fragmentation reactions of protonated peptides containing glutamine or glutamic acid. *Journal of the American Society for Mass Spectrometry*, 14(2), 155-165.
- Tamura, O., et al. (2005). Stereoselective Syntheses of 4-hydroxy 4-substituted Glutamic Acids. *The Journal of Organic Chemistry*, 70(12), 4569-4577.
- Godugu, B., et al. (2011). Effect of N-terminal glutamic acid and glutamine on fragmentation of peptide ions. *Journal of the American Society for Mass Spectrometry*, 22(1), 88-96.
- Medina, R., et al. (2000). Determination of Absolute Configurations of Amines and Amino Acids Using Nonchiral Derivatizing Agents (NCDA) and Deuterium NMR. *Organic Letters*, 2(14), 2111-2114.
- Godugu, B., et al. (2010). Effect of N-Terminal Glutamic Acid and Glutamine on Fragmentation of Peptide Ions. National Institute of Standards and Technology. [[Link](#)]
- Zhang, G., & Ben-Amotz, D. (2005). Fragmentation pathway for glutamine identification: Loss of 73 da from dimethylformamidinium glutamine isobutyl ester. *Journal of the American Society for Mass Spectrometry*, 16(7), 1192-1203.
- Hahn, M., et al. (2021). Novel Glycerophospholipid, Lipo- and N-acyl Amino Acids from Bacteroidetes: Isolation, Structure Elucidation and Bioactivity. *Marine Drugs*, 19(9), 493.
- Wang, Y., et al. (2023). <sup>19</sup>F NMR enantiodiscrimination and diastereomeric purity determination of amino acids, dipeptides, and amines. *Analyst*, 148(17), 4165-4171.
- Zhang, G., & Ben-Amotz, D. (2005). Fragmentation pathway for glutamine identification. Purdue University. [[Link](#)]
- Wehbe, J., et al. (2004). Enantioselective synthesis of new 4-substituted glutamic acid derivatives. *Tetrahedron: Asymmetry*, 15(5), 851-858.
- Ezquerra, J., et al. (1996). Synthesis of Enantiomerically Pure 4-Substituted Glutamic Acids and Prolines: General Aldol Reaction of Pyroglutamate Lactam Lithium Enolate Mediated by

Et2O.cntdot.BF3. The Journal of Organic Chemistry, 61(17), 5804-5812.

- Gibbons, W. A., et al. (1970). Homonuclear Internuclear Double Resonance Spectroscopy as a Basis for Determination of Amino Acid Conformation. Proceedings of the National Academy of Sciences, 67(2), 831-838.
- Wüthrich, K. (2003). Introduction to NMR spectroscopy of proteins. In Encyclopedia of Life Sciences. John Wiley & Sons, Ltd.
- Ezquerra, J., & Pedregal, C. (2002). Process for synthesizing L-γ-methylene glutamic acid and analogs.
- Schmieder, P. (2003). 5 Protein Structure Determination by NMR-Spectroscopy. Freie Universität Berlin. [\[Link\]](#)
- Kam, Y., et al. (2004). Synthesis and characterization of branched poly(L-glutamic acid) as a biodegradable drug carrier. Journal of Controlled Release, 95(2), 249-259.
- Cordeiro, R. S., et al. (2013). Structural characterization of a novel amino acid decarboxylase.
- Stefanucci, A., et al. (2014). PYROGLUTAMIC ACID DERIVATIVES: BUILDING BLOCKS FOR DRUG DISCOVERY. Current Bioactive Compounds, 10(2), 79-96.
- Khan Academy. Amino acid structure and classifications. [\[Link\]](#)
- NextSDS. (4S)-4-BENZYL-L-GLUTAMIC ACID — Chemical Substance Information. [\[Link\]](#)
- Baldwin, J. E., & Adlington, R. M. (1997). Synthesis of Novel Heterocyclic α-Amino Acids. Open University.
- Moldovan, O.-L., et al. (2025). In Vitro Evaluation of the Antibacterial Effect and Influence on the Bacterial Biofilm Formation of Glutamic Acid and Some Structural Analogues.
- Sangeetha, J., & Philip, J. (2025). Microbial Poly-(glutamic acid): Production, Biosynthesis, Properties, and Their Applications in the Food and Biomedicals. Preprints.org.
- Colbach, D. (2020). Synthesis and characterization of self-assembling glutamic acid isopeptides. Max-Planck-Gesellschaft.
- Lim, S. J., et al. (2021). Design and synthesis of a new orthogonally protected glutamic acid analog and its use in the preparation of high affinity polo-I. DSpace@MIT.
- Exposome-Explorer. Glutamic acid (Compound). [\[Link\]](#)
- Moldovan, O.-L., et al. (2025). In Vitro Evaluation of the Antibacterial Effect and Influence on the Bacterial Biofilm Formation of Glutamic Acid and Some Structural Analogues. PMC.

- Nguyen, L. T., et al. (2016). Roles of d-Amino Acids on the Bioactivity of Host Defense Peptides. *International Journal of Molecular Sciences*, 17(7), 1045.
- Al-Ani, I., et al. (2024). Poly-Gamma-Glutamic Acid Nanopolymer Effect against Bacterial Biofilms: In Vitro and In Vivo Study. *International Journal of Molecular Sciences*, 25(3), 1461.

### Need Custom Synthesis?

BenchChem offers custom synthesis for rare earth carbides and specific isotopic labeling.

Email: [info@benchchem.com](mailto:info@benchchem.com) or [Request Quote Online](#).

## Sources

- [1. Khan Academy \[khanacademy.org\]](#)
- [2. researchgate.net \[researchgate.net\]](#)
- [3. In Vitro Evaluation of the Antibacterial Effect and Influence on the Bacterial Biofilm Formation of Glutamic Acid and Some Structural Analogues - PMC \[pmc.ncbi.nlm.nih.gov\]](#)
- [4. research.cbc.osu.edu \[research.cbc.osu.edu\]](#)
- [5. sigmaaldrich.com \[sigmaaldrich.com\]](#)
- [6. Chiral Chromatographic Analysis of Amino Acids with Pre-column Derivatization by o-Phthalaldehyde: Improving the Determination of Enantiomers Using Ion-Pair Reagents - PMC \[pmc.ncbi.nlm.nih.gov\]](#)
- [7. jascoinc.com \[jascoinc.com\]](#)
- [8. phenomenex.com \[phenomenex.com\]](#)
- [9. tandfonline.com \[tandfonline.com\]](#)
- [10. pubs.acs.org \[pubs.acs.org\]](#)
- [11. Fragmentation reactions of protonated peptides containing glutamine or glutamic acid - PubMed \[pubmed.ncbi.nlm.nih.gov\]](#)
- [12. pubs.acs.org \[pubs.acs.org\]](#)
- [13. Effect of N-Terminal Glutamic Acid and Glutamine on Fragmentation of Peptide Ions | NIST \[nist.gov\]](#)
- To cite this document: BenchChem. [Technical Guide: Structure Elucidation of (4S)-4-(4-Methoxybenzyl)-L-glutamic acid]. BenchChem, [2026]. [Online PDF]. Available at:

[\[https://www.benchchem.com/product/b13918817/docs#technical-guide-structure-elucidation-of-4s-4-4-methoxybenzyl-l-glutamic-acid\]](https://www.benchchem.com/product/b13918817/docs#technical-guide-structure-elucidation-of-4s-4-4-methoxybenzyl-l-glutamic-acid)

### Disclaimer & Data Validity:

The information provided in this document is for Research Use Only (RUO) and is strictly not intended for diagnostic or therapeutic procedures. While BenchChem strives to provide accurate protocols, we make no warranties, express or implied, regarding the fitness of this product for every specific experimental setup.

**Technical Support:** The protocols provided are for reference purposes. Unsure if this reagent suits your experiment?

**Need Industrial/Bulk Grade?** [Request Custom Synthesis Quote](#)

## BenchChem

Our mission is to be the trusted global source of essential and advanced chemicals, empowering scientists and researchers to drive progress in science and industry.

### Contact

Address: 3281 E Guasti Rd  
Ontario, CA 91761, United States  
Phone: (601) 213-4426  
Email: [info@benchchem.com](mailto:info@benchchem.com)

[Contact our Ph.D. Support Team for a compatibility check](#)