

Physicochemical Profiling of Dinitropyrazoles: A Technical Guide

Author: BenchChem Technical Support Team. **Date:** April 2026

Compound of Interest

Compound Name: *methyl 1,4-dinitro-1H-pyrazole-3-carboxylate*

CAS No.: *1002535-20-7*

Cat. No.: *B13918652*

[Get Quote](#)

Executive Summary

Dinitropyrazoles (DNPs) represent a critical class of nitrogen-rich heterocycles characterized by high crystal densities, positive heats of formation, and significant thermal stability.[1][2][3] While primarily utilized as insensitive high explosives (IHEs) and melt-castable energetic matrices, they serve as potent synthons in medicinal chemistry for accessing poly-functionalized pyrazole scaffolds (e.g., diaminopyrazoles).

This guide focuses on the two primary isomers—3,4-dinitropyrazole (3,4-DNP) and 3,5-dinitropyrazole (3,5-DNP)—and the advanced derivative 4-amino-3,5-dinitropyrazole (LLM-116).[1] We analyze the structure-property relationships that dictate their thermodynamic behavior and provide validated protocols for their synthesis and characterization.

Structural Isomerism & Molecular Architecture

The physicochemical divergence between 3,4-DNP and 3,5-DNP arises from the positioning of the nitro groups relative to the acidic N-H proton. This structural variation fundamentally alters the hydrogen-bonding network, crystal packing, and resulting bulk properties.[4]

Comparative Physicochemical Data

The following table summarizes the key properties of the isomers compared to the standard explosive TNT.

Property	3,4-Dinitropyrazole (3,4-DNP)	3,5-Dinitropyrazole (3,5-DNP)	LLM-116 (4-amino-3,5-DNP)	TNT (Reference)
Formula	C ₃ H ₂ N ₄ O ₄	C ₃ H ₂ N ₄ O ₄	C ₃ H ₃ N ₅ O ₄	C ₇ H ₅ N ₃ O ₆
Crystal Density (g/cm ³)	1.87	1.80	1.90	1.65
Melting Point (°C)	86 – 88	173 – 174	178 (dec)	80
Decomp.[1][3] Temp (T_dec, °C)	~285	~317	> 290	~295
Acidity (pKa)	5.14	~5.0	3.6	N/A
Detonation Velocity (km/s)	8.10	7.76	8.50	6.90
Detonation Pressure (GPa)	29.4	25.6	32.0	21.0

Structural Logic

- **3,4-DNP (High Density / Low Melting Point):** The asymmetry of the 3,4-substitution allows for efficient crystal packing (high density) but disrupts the symmetry required for a robust intermolecular hydrogen-bonding lattice, resulting in a lower melting point (86–88 °C). This makes 3,4-DNP an ideal candidate for melt-cast explosive formulations.[5]
- **3,5-DNP (High Stability):** The symmetric 3,5-substitution facilitates strong intermolecular hydrogen bonding, significantly elevating the melting point (~173 °C) and thermal stability, but slightly reducing crystal density.

Synthetic Pathways & Causality

The synthesis of dinitropyrazoles is non-trivial due to the deactivating nature of the pyrazole ring after the introduction of the first nitro group. Direct dinitration is difficult; therefore, rearrangement mechanisms are employed.

Synthesis Workflow (Graphviz Visualization)

The following diagram illustrates the divergent pathways to access 3,4-DNP and 3,5-DNP, highlighting the critical thermal rearrangement step.

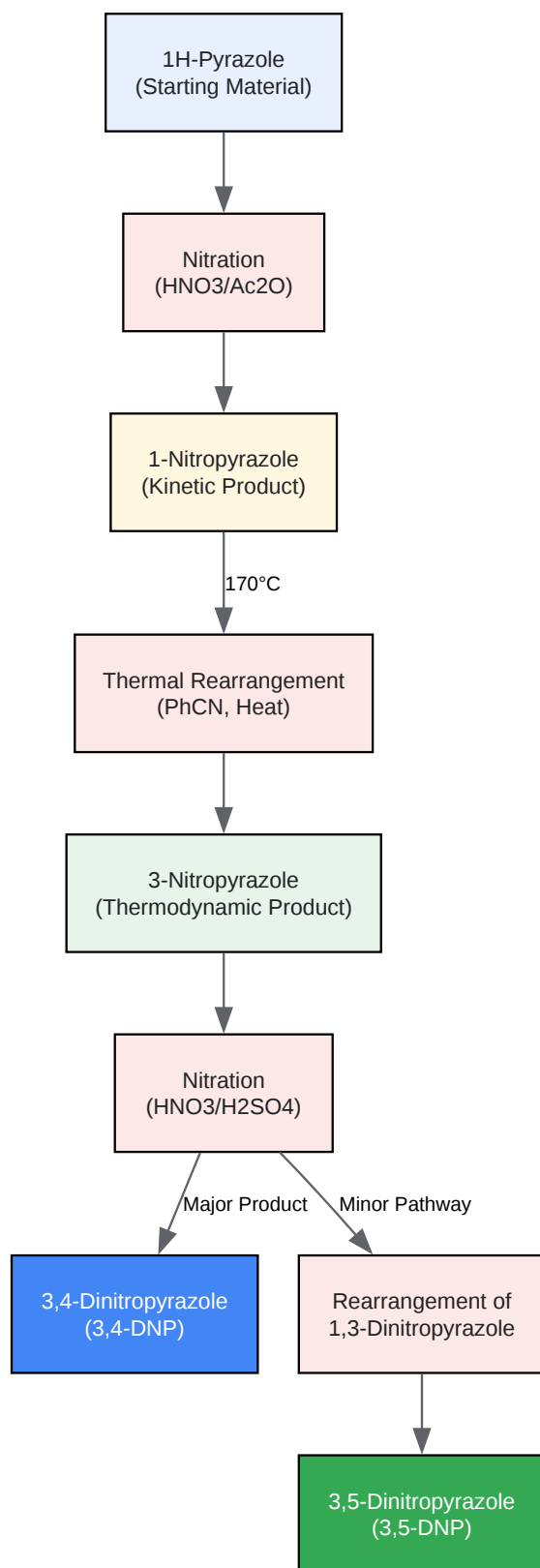

[Click to download full resolution via product page](#)

Figure 1: Divergent synthetic pathways for 3,4- and 3,5-dinitropyrazoles via nitration-rearrangement sequences.

Detailed Protocol: Synthesis of 3,4-Dinitropyrazole

Objective: Isolate high-purity 3,4-DNP suitable for physicochemical characterization.

- Nitration of Pyrazole:
 - Dissolve pyrazole in acetic anhydride. Add fuming nitric acid dropwise at 0–5 °C.
 - Causality: Acetic anhydride acts as a dehydrating agent, forming the active nitronium ion () while mitigating the exotherm.
 - Pour onto ice to precipitate 1-nitropyrazole.
- Thermal Rearrangement:
 - Heat 1-nitropyrazole in benzonitrile at 170 °C for 4 hours.
 - Mechanism:^{[6][7][8]} A [1,5]-sigmatropic shift of the nitro group occurs from N1 to C3 (forming 3-nitropyrazole).
- Second Nitration:
 - Dissolve 3-nitropyrazole in mixed acid (conc. / fuming). Heat to 100 °C.
 - Causality: The C4 position is the most nucleophilic site remaining on the electron-deficient ring.
 - Quench on ice. Filter the precipitate.
- Purification:
 - Recrystallize from water or ethanol.

- Validation: Purity is confirmed via HPLC and differential scanning calorimetry (DSC) (sharp endotherm at ~87 °C).

Advanced Characterization: LLM-116

4-Amino-3,5-dinitropyrazole (LLM-116) is a derivative that incorporates an amino group to enhance density and stability via "push-pull" electronic stabilization.

Vicarious Nucleophilic Substitution (VNS)

Unlike standard electrophilic aromatic substitution, LLM-116 is synthesized via VNS, which allows the introduction of a nucleophile (amine equivalent) onto an electron-poor aromatic ring containing leaving groups (or preserving the hydride).

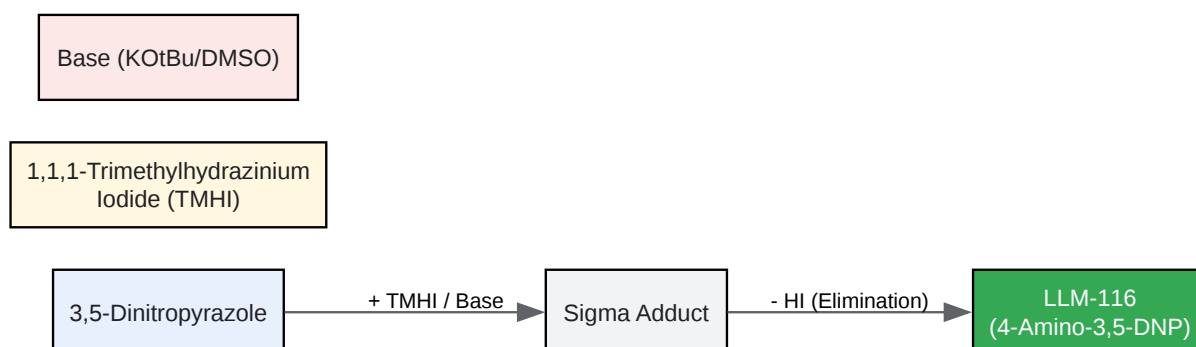

[Click to download full resolution via product page](#)

Figure 2: VNS mechanism for the synthesis of LLM-116.

Protocol Highlight:

- React 3,5-DNP with 1,1,1-trimethylhydrazinium iodide (TMHI) in DMSO with potassium tert-butoxide.
- Key Insight: The reaction must be kept anhydrous. Water quenches the anionic sigma-adduct intermediate.

Physicochemical Analysis Methodologies

Thermal Stability Profiling (DSC/TGA)

Thermal behavior is the primary safety metric for DNPs.

- Protocol: Load 2–5 mg of sample into an aluminum pan (pinhole lid).
- Ramp Rate: 5 °C/min under Nitrogen flow (50 mL/min).
- Interpretation:
 - Endotherm: Represents melting (e.g., 87 °C for 3,4-DNP).
 - Exotherm: Represents decomposition.[9] A sharp, narrow peak indicates rapid energy release (potential for detonation). A broad peak suggests slow thermal degradation.
 - Note: 3,5-DNP shows a significantly higher decomposition onset (~317 °C) than 3,4-DNP (~285 °C), correlating with its symmetric stability.

Density Measurement (Gas Pycnometry)

Density is directly proportional to detonation pressure ().

- Method: Helium Gas Pycnometry at 25 °C.
- Self-Validation: Run a standard (e.g., Teflon ball of known volume) before the sample.
- Result: 3,4-DNP should yield ~1.87 g/cm³. [1] Values <1.85 g/cm³ indicate solvent inclusion or crystal defects.

Acidity and Salt Formation

The N-H proton in DNPs is highly acidic () due to the electron-withdrawing nitro groups.

- Application: This acidity allows for the formation of energetic salts (e.g., ammonium, hydrazinium salts) which often possess higher densities and lower vapor pressures than the neutral parent.

- **Pharma Relevance:** This pKa range is similar to carboxylic acids, making DNPs bio-isosteres for acidic pharmacophores in specific contexts, or allowing them to serve as intermediates for N-alkylation reactions.

Safety & Handling

DNPs are energetic materials.^{[1][4][10]} While "insensitive," they possess high potential energy.

- **Impact Sensitivity:** 3,4-DNP is moderately sensitive (comparable to TNT).
- **Friction Sensitivity:** Generally insensitive (> 360 N).^[11]
- **Hygroscopicity:** 3,4-DNP is known to be hygroscopic. Storage in desiccated environments is mandatory to prevent hydrolysis or density loss.

References

- Recent Advances in Synthesis and Properties of Nitrated-Pyrazoles Based Energetic Compounds. *Molecules*, 2020.
- Synthesis and Energetic Properties of N-Substituted 3,4- and 3,5-Dinitropyrazoles. *ACS Omega*, 2023.
- Isomers of Dinitropyrazoles: Synthesis, Comparison and Tuning of their Physicochemical Properties. *Chemistry - A European Journal*, 2018.
- Synthesis and Properties of a New Explosive, 4-Amino-3,5-Dinitro-1H-Pyrazole (LLM-116). Lawrence Livermore National Laboratory Report, 2001.
- Comparative Studies on Thermal Decompositions of Dinitropyrazole-Based Energetic Materials. *Molecules*, 2021.
- Study on the Hygroscopic Properties and Mechanism of Novel Melt-Cast Matrix 3,4-Dinitropyrazole (DNP). *Materials*, 2023.

Need Custom Synthesis?

BenchChem offers custom synthesis for rare earth carbides and specific isotopic labeling.

Email: info@benchchem.com or [Request Quote Online](#).

Sources

- [1. mdpi.com \[mdpi.com\]](https://www.mdpi.com)
- [2. Synthesis and Energetic Properties of N-Substituted 3,4- and 3,5-Dinitropyrazoles - PMC \[pmc.ncbi.nlm.nih.gov\]](https://pubmed.ncbi.nlm.nih.gov/31111111/)
- [3. pubs.acs.org \[pubs.acs.org\]](https://pubs.acs.org)
- [4. Study on the Hygroscopic Properties and Mechanism of Novel Melt-Cast Matrix 3,4-Dinitropyrazole \(DNP\) - PMC \[pmc.ncbi.nlm.nih.gov\]](https://pubmed.ncbi.nlm.nih.gov/31111111/)
- [5. researchgate.net \[researchgate.net\]](https://www.researchgate.net)
- [6. osti.gov \[osti.gov\]](https://www.osti.gov)
- [7. mdpi.com \[mdpi.com\]](https://www.mdpi.com)
- [8. Comparative Studies on Thermal Decompositions of Dinitropyrazole-Based Energetic Materials - PMC \[pmc.ncbi.nlm.nih.gov\]](https://pubmed.ncbi.nlm.nih.gov/31111111/)
- [9. researchgate.net \[researchgate.net\]](https://www.researchgate.net)
- [10. pubs.acs.org \[pubs.acs.org\]](https://pubs.acs.org)
- [11. Isomers of Dinitropyrazoles: Synthesis, Comparison and Tuning of their Physicochemical Properties - PubMed \[pubmed.ncbi.nlm.nih.gov\]](https://pubmed.ncbi.nlm.nih.gov/31111111/)
- To cite this document: BenchChem. [Physicochemical Profiling of Dinitropyrazoles: A Technical Guide]. BenchChem, [2026]. [Online PDF]. Available at: [\[https://www.benchchem.com/product/b13918652/docs#physicochemical-profiling-of-dinitropyrazoles-a-technical-guide\]](https://www.benchchem.com/product/b13918652/docs#physicochemical-profiling-of-dinitropyrazoles-a-technical-guide)

Disclaimer & Data Validity:

The information provided in this document is for Research Use Only (RUO) and is strictly not intended for diagnostic or therapeutic procedures. While BenchChem strives to provide accurate protocols, we make no warranties, express or implied, regarding the fitness of this product for every specific experimental setup.

Technical Support: The protocols provided are for reference purposes. Unsure if this reagent suits your experiment?

Need Industrial/Bulk Grade? [Request Custom Synthesis Quote](#)

BenchChem

Our mission is to be the trusted global source of essential and advanced chemicals, empowering scientists and researchers to drive progress in science and industry.

Contact

Address: 3281 E Guasti Rd
Ontario, CA 91761, United States
Phone: (601) 213-4426
Email: info@benchchem.com

[Contact our Ph.D. Support Team for a compatibility check](#)