

Comparative Analysis of LYN Proto-Oncogene Expression: A Tale of Two Tissues

Author: BenchChem Technical Support Team. **Date:** April 2026

Compound of Interest

Compound Name: LYCBX
Cat. No.: B13914502

[Get Quote](#)

A detailed examination of LYN proto-oncogene, Src family tyrosine kinase (LYN) expression reveals a significant upregulation in various diseased tissues, particularly in cancer, when compared to its baseline expression in healthy tissues. This guide provides a comparative analysis of LYN expression, presenting supporting experimental data, detailed methodologies, and visualizations of its key signaling pathways.

LYN, a member of the Src family of protein tyrosine kinases, plays a crucial role in regulating a multitude of cellular processes, including cell proliferation, differentiation, migration, and apoptosis.^[1] While it is an essential mediator in normal cellular signaling, particularly in hematopoietic cells, its dysregulation is strongly implicated in the pathology of several diseases, most notably in various forms of cancer.^{[2][3]} In healthy tissues, LYN expression is most abundant in lymphoid tissues, with distinct membranous and cytoplasmic expression observed at variable levels in other tissues.^{[4][5]}

Quantitative Expression Analysis: Healthy vs. Diseased Tissues

The differential expression of LYN between healthy and cancerous tissues has been quantified in several studies. Below are summary tables compiling data from research on gastric and

cervical cancer, demonstrating a consistent upregulation of LYN at both the mRNA and protein levels in tumor tissues.

Table 1: LYN Expression in Gastric Cancer

Tissue Type	LYN mRNA Expression (Relative Quantification)	LYN Protein Expression (IHC Staining)	Reference
Normal Gastric Tissue	Lower Expression	Low to Moderate	[6]
Gastric Cancer Tissue	Significantly Upregulated (P<0.01)	Significantly Increased (P<0.05)	[6]

Table 2: LYN Expression in Cervical Cancer

Tissue Type	LYN Protein Expression (IHC Staining)	Correlation with Disease Progression	Reference
Normal Cervical Tissue	Low Expression	-	[7][8]
Cancer Adjacent Normal Tissue	Moderate Expression	-	[7][8]
Cervical Cancer Tissue	Significantly Increased (P<0.05)	Positive correlation with FIGO stage and tumor grade	[7][8]

Experimental Protocols

The following are detailed methodologies for key experiments commonly used to quantify LYN expression.

Reverse Transcription-Quantitative Polymerase Chain Reaction (RT-qPCR) for LYN mRNA Expression

This technique is used to measure the relative abundance of LYN mRNA in different tissue samples.

- **RNA Extraction:** Total RNA is isolated from healthy and diseased tissue samples using a suitable RNA extraction kit (e.g., RNeasy Kit, Qiagen) following the manufacturer's protocol. The quality and quantity of the extracted RNA are assessed using a spectrophotometer (e.g., NanoDrop).
- **Reverse Transcription:** First-strand complementary DNA (cDNA) is synthesized from the total RNA using a reverse transcriptase enzyme (e.g., SuperScript IV, Invitrogen) and random primers.
- **qPCR:** The qPCR is performed using a qPCR instrument (e.g., Applied Biosystems 7500) with a SYBR Green-based detection method. The reaction mixture includes the cDNA template, forward and reverse primers for LYN, and a housekeeping gene (e.g., GAPDH) for normalization.
 - LYN Forward Primer: 5'-TGTGGCCAAACTCAACACCT-3'[6]
 - LYN Reverse Primer: 5'-TGCTGCAGGGTCTTCATGAG-3'[6]
- **Data Analysis:** The relative expression of LYN mRNA is calculated using the $2^{-\Delta\Delta Cq}$ method, where the expression in diseased tissue is compared to that in healthy tissue after normalization to the housekeeping gene.[6]

Immunohistochemistry (IHC) for LYN Protein Expression and Localization

IHC is employed to visualize the presence and location of the LYN protein within tissue sections.

- **Tissue Preparation:** Formalin-fixed, paraffin-embedded tissue blocks of both healthy and diseased tissues are sectioned into 4-5 μm thick slices and mounted on glass slides.

- **Antigen Retrieval:** The tissue sections are deparaffinized and rehydrated. Antigen retrieval is performed by heating the slides in a citrate buffer (pH 6.0) to unmask the antigenic sites.
- **Immunostaining:**
 - The slides are incubated with a primary antibody specific for LYN.
 - After washing, a secondary antibody conjugated to an enzyme (e.g., horseradish peroxidase) is applied.
 - A chromogenic substrate (e.g., DAB) is added, which produces a colored precipitate at the site of the antigen-antibody reaction.
 - The sections are counterstained with hematoxylin to visualize the cell nuclei.
- **Imaging and Analysis:** The stained slides are examined under a microscope. The intensity and localization of the staining are scored to provide a semi-quantitative measure of protein expression.

Western Blotting for LYN Protein Quantification

This method allows for the quantification of LYN protein levels in tissue lysates.

- **Protein Extraction:** Total protein is extracted from tissue samples using a lysis buffer containing protease and phosphatase inhibitors. The protein concentration is determined using a protein assay (e.g., BCA assay).
- **SDS-PAGE and Transfer:** Equal amounts of protein from each sample are separated by size using sodium dodecyl sulfate-polyacrylamide gel electrophoresis (SDS-PAGE) and then transferred to a polyvinylidene difluoride (PVDF) membrane.
- **Immunoblotting:**
 - The membrane is blocked to prevent non-specific antibody binding and then incubated with a primary antibody against LYN.
 - After washing, the membrane is incubated with a secondary antibody conjugated to an enzyme (e.g., HRP).

- Detection: The protein bands are visualized using an enhanced chemiluminescence (ECL) detection system. The band intensity is quantified using densitometry software and normalized to a loading control protein (e.g., GAPDH or β -actin).

Signaling Pathways and Experimental Workflows

The dysregulation of LYN expression in diseased tissues, particularly cancer, leads to the aberrant activation of several downstream signaling pathways that promote tumorigenesis. The following diagrams illustrate some of the key pathways influenced by LYN.

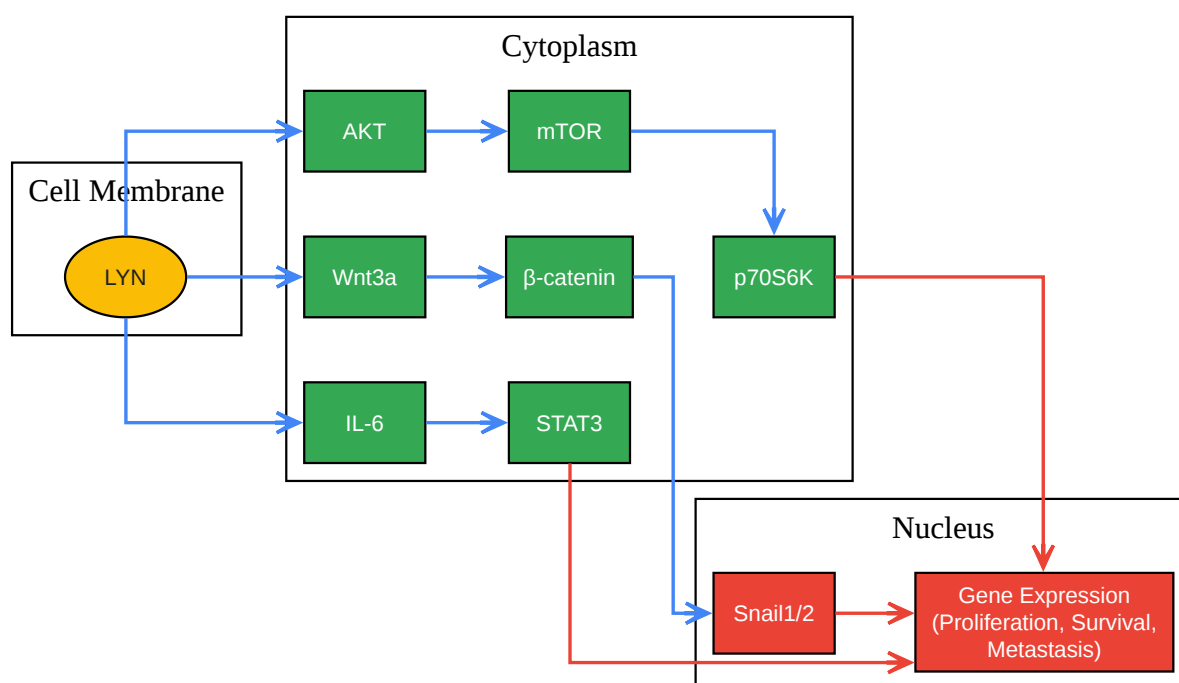

[Click to download full resolution via product page](#)

Caption: LYN-mediated oncogenic signaling pathways.

The diagram above illustrates how upregulated LYN in cancer cells can activate the Wnt/ β -catenin, AKT/mTOR, and IL-6/STAT3 signaling pathways, ultimately leading to changes in gene expression that promote tumor proliferation, survival, and metastasis.[7][8][9]

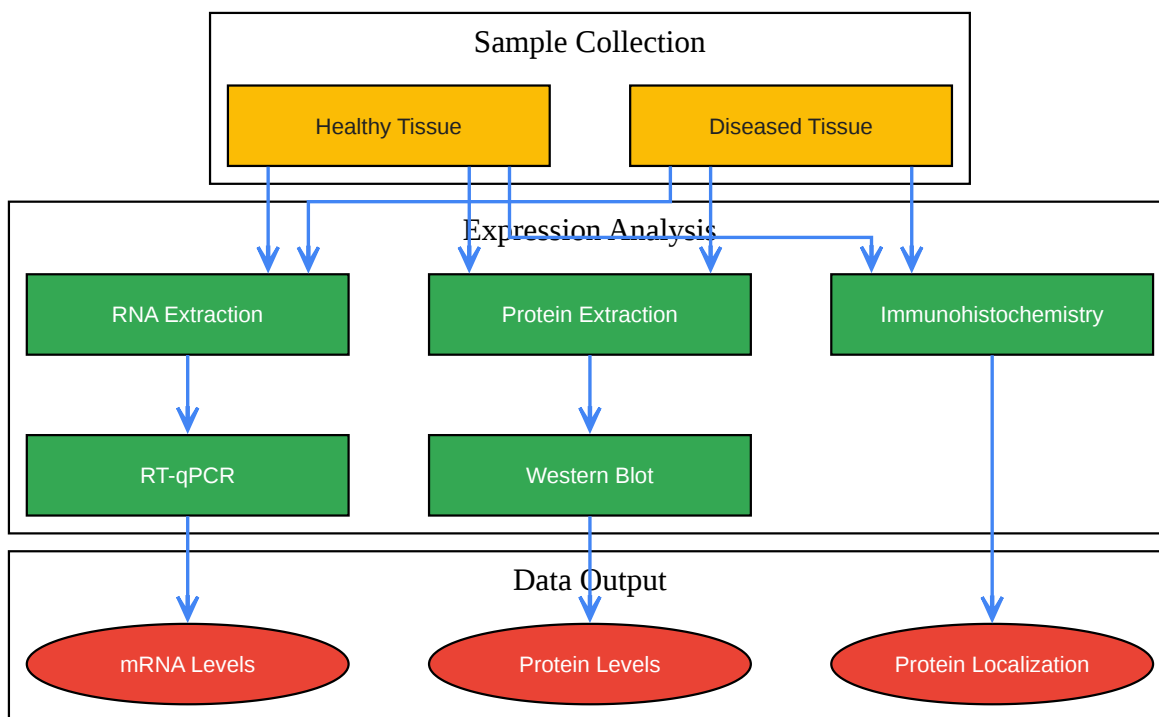

[Click to download full resolution via product page](#)

Need Custom Synthesis?

BenchChem offers custom synthesis for rare earth carbides and specific isotopic labeling.

Email: info@benchchem.com or [Request Quote Online](#).

References

- 1. Functions of the Lyn tyrosine kinase in health and disease - PubMed [pubmed.ncbi.nlm.nih.gov]
- 2. The Src-family Kinase Lyn in Immunoreceptor Signaling - PMC [pmc.ncbi.nlm.nih.gov]
- 3. [researchgate.net](https://www.researchgate.net) [[researchgate.net](https://www.researchgate.net)]
- 4. LYN protein expression summary - The Human Protein Atlas [[proteinatlas.org](https://www.proteinatlas.org)]
- 5. Tissue expression of LYN - Summary - The Human Protein Atlas [[proteinatlas.org](https://www.proteinatlas.org)]

- [6. Oncogenic role of LYN in human gastric cancer via the Wnt/ \$\beta\$ -catenin and AKT/mTOR pathways - PMC \[pmc.ncbi.nlm.nih.gov\]](#)
- [7. oncotarget.com \[oncotarget.com\]](#)
- [8. Tyrosine kinase LYN is an oncotarget in human cervical cancer: A quantitative proteomic based study - PubMed \[pubmed.ncbi.nlm.nih.gov\]](#)
- [9. spandidos-publications.com \[spandidos-publications.com\]](#)
- To cite this document: BenchChem. [Comparative Analysis of LYN Proto-Oncogene Expression: A Tale of Two Tissues]. BenchChem, [2026]. [Online PDF]. Available at: [<https://www.benchchem.com/product/b13914502/docs#comparative-analysis-of-lyn-proto-oncogene-expression-a-tale-of-two-tissues>]

Disclaimer & Data Validity:

The information provided in this document is for Research Use Only (RUO) and is strictly not intended for diagnostic or therapeutic procedures. While BenchChem strives to provide accurate protocols, we make no warranties, express or implied, regarding the fitness of this product for every specific experimental setup.

Technical Support: The protocols provided are for reference purposes. Unsure if this reagent suits your experiment?

Need Industrial/Bulk Grade? [Request Custom Synthesis Quote](#)

BenchChem

Our mission is to be the trusted global source of essential and advanced chemicals, empowering scientists and researchers to drive progress in science and industry.

Contact

Address: 3281 E Guasti Rd
Ontario, CA 91761, United States
Phone: (601) 213-4426
Email: info@benchchem.com

Contact our Ph.D. Support Team for a compatibility check