

Application Note: Experimental Protocols for N-Oxide Formation of Pyrazines

Author: BenchChem Technical Support Team. **Date:** May 2026

Compound of Interest

Compound Name: *Methyl 5,6-dimethylpyrazine-2-carboxylate*

CAS No.: *1234504-26-7*

Cat. No.: *B1391444*

[Get Quote](#)

Abstract

Pyrazine N-oxides are critical intermediates in medicinal chemistry, serving as precursors for functionalized pyrazines via the Boekelheide rearrangement or nucleophilic aromatic substitution (

Ar). However, their synthesis is often complicated by regioselectivity issues (mono- vs. di-oxidation) and safety hazards associated with organic peroxides. This guide provides three validated protocols for the N-oxidation of pyrazines, rationalized by mechanistic insights into substituent effects. We detail the use of m-CPBA, hydrogen peroxide/acetic acid, and Oxone® (potassium peroxydisulfate) to cover a wide range of substrate classes.

Mechanistic Principles & Regioselectivity

The formation of pyrazine N-oxides proceeds via the electrophilic attack of an oxidant (typically a peracid or dioxirane) on the lone pair of the pyrazine nitrogen. Unlike pyridines, pyrazines possess two nucleophilic nitrogen atoms. Controlling the oxidation state (mono- vs. di-N-oxide) and regioselectivity (N1 vs. N4) is the primary challenge.

Electronic and Steric Directing Effects

The regioselectivity is governed by the interplay of electronic activation and steric hindrance:

- **Electron-Donating Groups (EDGs):** Substituents like alkyl (-R) or alkoxy (-OR) groups increase the electron density of the pyrazine ring. Inductive and resonance effects make the adjacent nitrogen (N1) more nucleophilic, typically directing oxidation to the ortho position relative to the substituent.
- **Electron-Withdrawing Groups (EWGs):** Substituents like halogens (-Cl, -Br), esters (-COOR), or nitro (-NO₂) groups deactivate the ring. The inductive withdrawal is strongest at the adjacent nitrogen, rendering the distal nitrogen (N4) relatively more nucleophilic and the preferred site of oxidation.

Visualization of Regiochemistry

The following diagram illustrates the mechanistic pathways and directing effects.

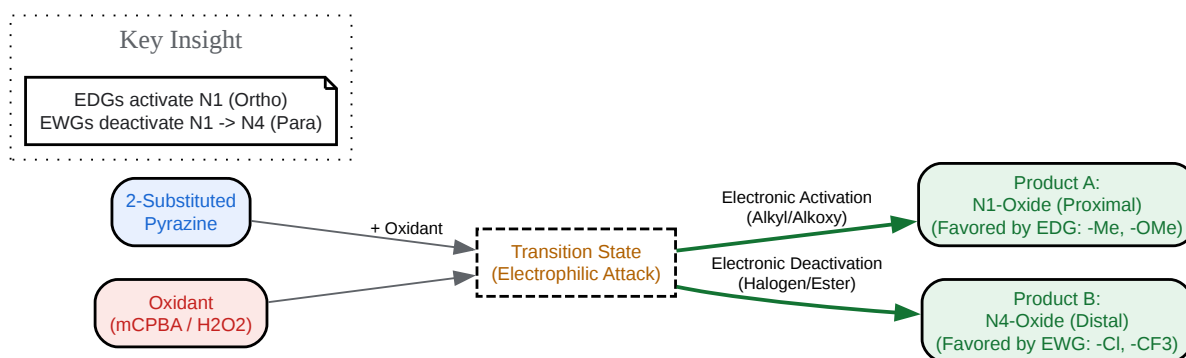

[Click to download full resolution via product page](#)

Figure 1: Mechanistic pathway and regiochemical outcomes based on substituent electronics.

Method Selection Guide

Selecting the correct oxidant is crucial for yield, safety, and purification. Use the decision matrix below to choose the optimal protocol.

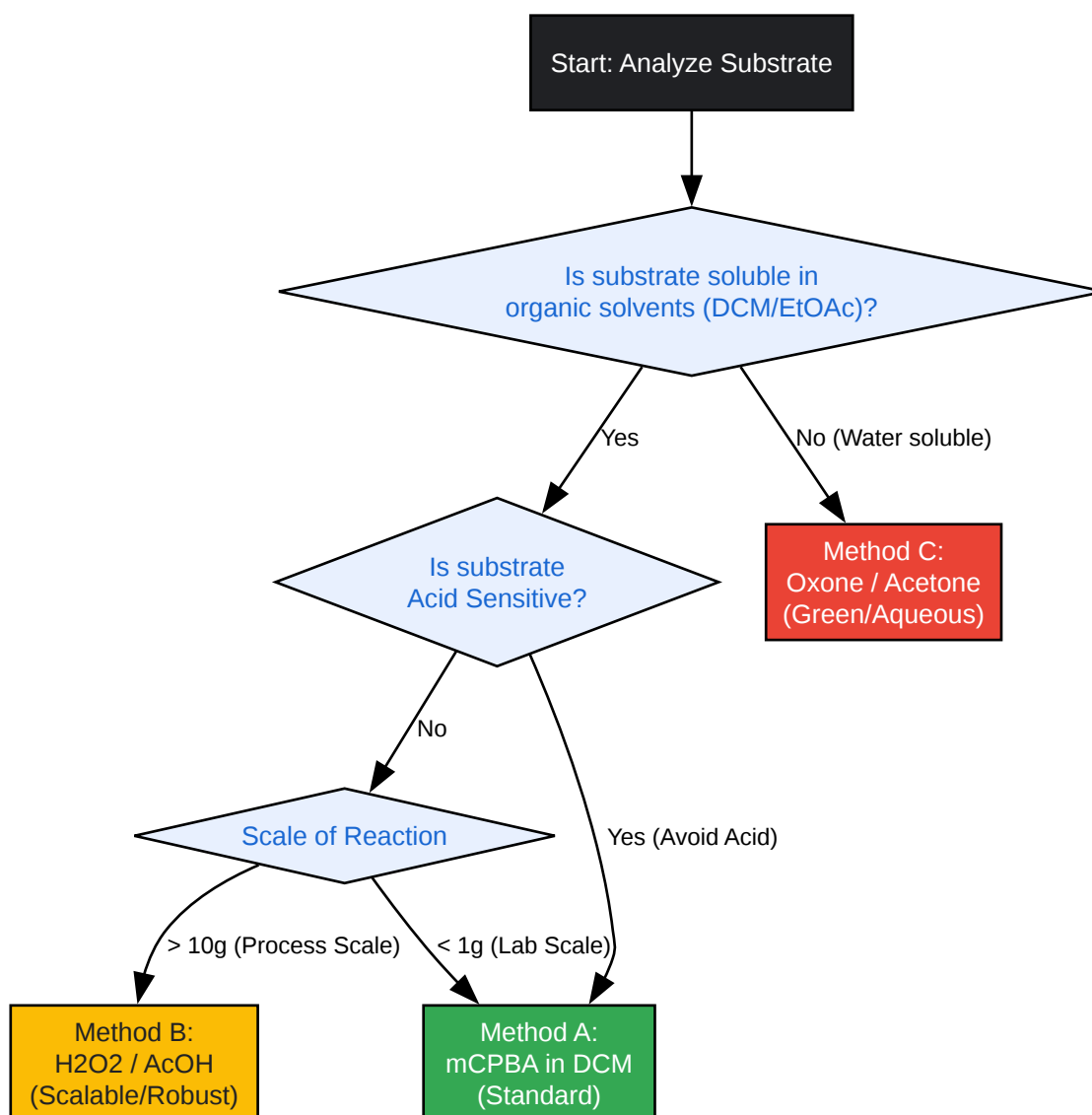

[Click to download full resolution via product page](#)

Figure 2: Decision tree for selecting the appropriate N-oxidation protocol.

Experimental Protocols

Protocol A: m-CPBA Oxidation (Standard Lab Scale)

Best for: Lipophilic substrates, acid-sensitive functional groups, small-scale (<5 g). Mechanism: Direct oxygen transfer from peracid.

Reagents:

- Substrate (1.0 equiv)
- m-CPBA (meta-chloroperbenzoic acid, 70-77% wt, 1.1–1.5 equiv)
- Solvent: Dichloromethane (DCM) or Chloroform

Procedure:

- **Dissolution:** Dissolve the pyrazine substrate (e.g., 2-methylpyrazine, 10 mmol) in DCM (50 mL, 0.2 M) in a round-bottom flask.
- **Addition:** Cool the solution to 0 °C using an ice bath. Add m-CPBA (1.2 equiv) portion-wise over 15 minutes. Note: m-CPBA is often a solid; ensure complete dissolution.
- **Reaction:** Remove the ice bath and stir at room temperature (20–25 °C). Monitor by TLC or LCMS.
 - **Reaction Time:** Typically 2–12 hours. Electron-deficient pyrazines may require reflux (40 °C) or extended time.
- **Quenching (Critical Safety Step):** Once conversion is complete, cool to 0 °C. Add saturated aqueous (sodium thiosulfate) or (sodium sulfite) and stir vigorously for 20 minutes to destroy excess peroxide. Test the aqueous layer with starch-iodide paper (should remain white/colorless).
- **Workup:**
 - Wash the organic layer with saturated (2 x 30 mL) to remove m-chlorobenzoic acid byproduct.
 - Dry over , filter, and concentrate in vacuo.

- Purification: The crude N-oxide is often solid. Purify by recrystallization (EtOAc/Hexane) or silica gel chromatography (typically requires polar eluent: 5–10% MeOH in DCM).

Protocol B: Hydrogen Peroxide / Acetic Acid (Scalable)

Best for: Large scale (>10 g), electron-deficient pyrazines, cost-efficiency. Mechanism: In situ formation of peracetic acid.

Reagents:

- Substrate (1.0 equiv)
- Hydrogen Peroxide (30% or 50% aq., 1.5–3.0 equiv)
- Solvent: Glacial Acetic Acid (AcOH)

Procedure:

- Setup: Dissolve the pyrazine (50 mmol) in glacial acetic acid (50 mL).
- Addition: Add 30% (1.5 equiv) dropwise at room temperature.
- Heating: Heat the mixture to 60–80 °C.
 - Caution: Do not exceed 100 °C to avoid thermal decomposition of peracetic acid.
 - Monitoring: Pyrazines are deactivated; reaction may take 4–24 hours. Add additional (0.5 equiv) if conversion stalls after 12 hours.
- Workup:
 - Concentrate the reaction mixture under reduced pressure to remove most AcOH (azeotrope with toluene if necessary).
 - Dilute residue with water, neutralize with solid

(careful: foaming) to pH 8.

- Extract with DCM or Chloroform/Isopropanol (3:1) for polar N-oxides.
- Purification: Recrystallization is preferred for large batches.

Protocol C: Oxone® / Acetone (Green Chemistry)

Best for: Water-soluble substrates, avoiding chlorinated solvents, "Green" requirements.

Mechanism: In situ generation of dimethyldioxirane (DMDO).

Reagents:

- Substrate (1.0 equiv)
- Oxone® (Potassium peroxymonosulfate, 1.2–1.5 equiv)
- Sodium Bicarbonate (, 3–5 equiv)
- Solvent: Acetone/Water (1:1 or 2:1)

Procedure:

- Preparation: Dissolve substrate (5 mmol) in Acetone/Water (20 mL, 1:1 v/v).
- Addition: Add solid to the stirring solution.
- Reaction: Cool to 0–5 °C. Add Oxone® solid portion-wise or as an aqueous solution dropwise over 30 minutes. The mixture will become a slurry.
- Stirring: Stir at room temperature for 1–4 hours. The acetone acts as a catalyst carrier (via DMDO).
- Workup:
 - Filter off the inorganic salts.

- Concentrate the filtrate to remove acetone.
- Extract the aqueous residue with EtOAc or DCM.
- Note: This method yields very clean products, often requiring no chromatography.

Process Safety & Troubleshooting

Critical Safety Parameters

- Peroxide Detection: Never concentrate a reaction mixture containing excess peroxides. Always quench with a reducing agent (

 or

) until a negative starch-iodide test is obtained.
- Exotherms: The oxidation reaction is exothermic.[1] On a large scale (>100 g), controlled addition of the oxidant and active cooling are mandatory.
- Metal Contamination: Trace metals (Fe, Cu) can catalyze the rapid decomposition of peroxides. Use glass-lined or passivated stainless steel equipment for scale-up.

Troubleshooting Table

Issue	Probable Cause	Corrective Action
Low Conversion	Electron-deficient ring	Switch to Method B (higher T) or use Trifluoroacetic acid (TFAA).
Di-N-oxide Formation	Excess oxidant / High T	Strictly control stoichiometry (1.0–1.1 equiv). Lower temperature.
Poor Solubility	Highly polar product	Use continuous extraction (CHCl ₃) or lyophilization for water-soluble N-oxides.
Regioisomer Mix	Similar sterics/electronics	Separate via column chromatography (slow gradient) or recrystallize.

References

- Sato, N. (2000). "Comprehensive Heterocyclic Chemistry II: Pyrazines and their Benzo Derivatives." Pergamon.
- Ohta, A., & Watanabe, T. (1973). "Pyrazines.[2][3][4][5] I. Pyrazine N-oxides." [3][5][6][7][8][9] [10] Chemical & Pharmaceutical Bulletin, 21(9), 1845-1854.
- McKay, S. E., et al. (2001). "Oxidation methods for aromatic diazines: Substituted pyrazine-N-oxides." Heterocyclic Communications, 7(4), 307-312.
- Miyamoto, H., et al. (1990). "Synthesis of Pyrazine N-Oxides." Synlett, 1990(10), 587.
- American Chemical Society. (2023). "Safety Guidelines for Handling Organic Peroxides."

Need Custom Synthesis?

BenchChem offers custom synthesis for rare earth carbides and specific isotopic labeling.

Email: info@benchchem.com or [Request Quote Online](#).

Sources

- [1. Thieme E-Journals - Synfacts / Abstract \[thieme-connect.com\]](#)
- [2. Synthesis and reactions of Pyrazine | PPTX \[slideshare.net\]](#)
- [3. researchgate.net \[researchgate.net\]](#)
- [4. Redetermination of 2-methyl-4-nitropyridine N-oxide - PMC \[pmc.ncbi.nlm.nih.gov\]](#)
- [5. Thieme E-Books & E-Journals \[thieme-connect.de\]](#)
- [6. researchgate.net \[researchgate.net\]](#)
- [7. Studies on pyrazines. Part 25. Lewis acid-promoted deoxidative thiation of pyrazine N-oxides: new protocol for the synthesis of 3-substituted pyrazinethiols - Journal of the Chemical Society, Perkin Transactions 1 \(RSC Publishing\) \[pubs.rsc.org\]](#)
- [8. pubs.acs.org \[pubs.acs.org\]](#)
- [9. Preparation and reactions of some substituted pyrazine di-N-oxides - Journal of the Chemical Society C: Organic \(RSC Publishing\) \[pubs.rsc.org\]](#)
- [10. Pyrazine and Phenazine Heterocycles: Platforms for Total Synthesis and Drug Discovery - PMC \[pmc.ncbi.nlm.nih.gov\]](#)
- [To cite this document: BenchChem. \[Application Note: Experimental Protocols for N-Oxide Formation of Pyrazines\]. BenchChem, \[2026\]. \[Online PDF\]. Available at: \[https://www.benchchem.com/product/b1391444/docs#application-note-experimental-protocols-for-n-oxide-formation-of-pyrazines\]](#)

Disclaimer & Data Validity:

The information provided in this document is for Research Use Only (RUO) and is strictly not intended for diagnostic or therapeutic procedures. While BenchChem strives to provide accurate protocols, we make no warranties, express or implied, regarding the fitness of this product for every specific experimental setup.

Technical Support: The protocols provided are for reference purposes. Unsure if this reagent suits your experiment?

Need Industrial/Bulk Grade? [Request Custom Synthesis Quote](#)

BenchChem

Our mission is to be the trusted global source of essential and advanced chemicals, empowering scientists and researchers to drive progress in science and industry.

Contact

Address: 3281 E Guasti Rd
Ontario, CA 91761, United States
Phone: (601) 213-4426
Email: info@benchchem.com

[Contact our Ph.D. Support Team for a compatibility check](#)