

4-Chloro-2-methoxy-5-methylbenzotrile NMR analysis

Author: BenchChem Technical Support Team. **Date:** May 2026

Compound of Interest

Compound Name: *4-Chloro-2-methoxy-5-methylbenzotrile*

CAS No.: *755027-31-7*

Cat. No.: *B1391815*

[Get Quote](#)

An In-depth Technical Guide to the NMR Analysis of **4-Chloro-2-methoxy-5-methylbenzotrile**

Introduction

In the landscape of pharmaceutical and materials science research, the precise structural elucidation of novel organic compounds is a cornerstone of development. **4-Chloro-2-methoxy-5-methylbenzotrile**, with the molecular formula C_9H_8ClNO and a molecular weight of 181.62 g/mol, represents a class of substituted aromatic nitriles that are common intermediates in organic synthesis.[1] Nuclear Magnetic Resonance (NMR) spectroscopy stands as the most powerful and definitive non-destructive technique for determining the molecular structure of such compounds in solution.[2][3]

This guide provides a comprehensive technical analysis of **4-chloro-2-methoxy-5-methylbenzotrile** using one-dimensional (1H , ^{13}C) and two-dimensional (HSQC, HMBC) NMR techniques. As a self-validating system, this document will not only present predicted

spectral data but also explain the underlying principles and experimental causality, empowering researchers to confidently assign the structure of this and related molecules.

Figure 1: Structure of **4-chloro-2-methoxy-5-methylbenzonitrile** with atom numbering.

Part 1: ^1H NMR Spectral Analysis: Predicting the Signature of Protons

The ^1H NMR spectrum provides foundational information based on the chemical environment, integration, and spin-spin coupling of protons. For **4-chloro-2-methoxy-5-methylbenzonitrile**, we expect four distinct signals.

Causality of Chemical Shifts and Multiplicity

The chemical shift (δ) of a proton is exquisitely sensitive to the electronic environment. In substituted benzenes, shifts generally appear between 6.5 and 8.5 ppm, downfield from the benchmark of benzene (7.3 ppm), due to the ring current effect.^{[4][5]} The specific position is dictated by the interplay of electron-donating groups (EDGs) and electron-withdrawing groups (EWGs).

- Aromatic Protons (H-3 and H-6):
 - Substituent Effects: The methoxy group ($-\text{OCH}_3$) at C-2 is a potent electron-donating group through resonance, increasing electron density (shielding) at the ortho (C-3) and para (C-6) positions. The methyl group ($-\text{CH}_3$) at C-5 is a weak EDG. Conversely, the nitrile ($-\text{CN}$) at C-1 and the chloro ($-\text{Cl}$) group at C-4 are electron-withdrawing, decreasing electron density (deshielding) and shifting signals downfield.
 - Prediction for H-3: This proton is ortho to the strongly shielding $-\text{OCH}_3$ group. This effect is dominant, so H-3 is expected to be the most upfield of the aromatic protons.
 - Prediction for H-6: This proton is influenced by several groups: it is para to the shielding $-\text{OCH}_3$, ortho to the shielding $-\text{CH}_3$, and ortho to the deshielding $-\text{Cl}$ group. The combined deshielding effect from the adjacent chloro and nitrile groups is expected to outweigh the shielding effects, placing H-6 downfield relative to H-3.

- Multiplicity: H-3 and H-6 are five bonds apart (para to each other). The coupling constant over this distance ($^5J_{HH}$) is typically 0 Hz. Therefore, both aromatic signals are predicted to be singlets (s).
- Methoxy Protons (-OCH₃): These three protons are equivalent and attached to an oxygen, which places their signal in the range of 3.5-4.0 ppm. They will appear as a sharp singlet (s) with an integration of 3H.
- Methyl Protons (-CH₃): These three protons are attached to the aromatic ring. Their signal typically appears around 2.2-2.5 ppm. They will also be a singlet (s) integrating to 3H.

Predicted ¹H NMR Data Summary

Proton Assignment	Predicted Chemical Shift (δ, ppm)	Multiplicity	Integration
H-6	~7.4 - 7.6	Singlet (s)	1H
H-3	~6.9 - 7.1	Singlet (s)	1H
-OCH ₃	~3.9 - 4.1	Singlet (s)	3H
-CH ₃	~2.3 - 2.5	Singlet (s)	3H

Part 2: ¹³C NMR Spectral Analysis: Mapping the Carbon Skeleton

The ¹³C NMR spectrum reveals every unique carbon atom in the molecule. Due to the lack of symmetry in **4-chloro-2-methoxy-5-methylbenzonitrile**, all nine carbons are chemically non-equivalent and should produce nine distinct signals. Aromatic carbons typically resonate in the 110-160 ppm range.^{[5][6]}

Causality of Chemical Shifts

- Substituent Effects on Aromatic Carbons:
 - C-1 (ipso-CN): The carbon attached to the electron-withdrawing nitrile group will be shielded and appear around 105-115 ppm. The nitrile carbon itself (-CN) will be further downfield (~118 ppm).

- C-2 (ipso-OCH₃): The oxygen atom strongly deshields the attached carbon, placing its signal far downfield, typically >155 ppm.
- C-3: This carbon is ortho to the -OCH₃ group and is expected to be shielded, appearing upfield in the aromatic region.
- C-4 (ipso-Cl): The carbon bearing the chlorine atom will be deshielded and is expected in the 130-140 ppm range.
- C-5 (ipso-CH₃): The methyl-substituted carbon will be deshielded, appearing around 135-145 ppm.
- C-6: This carbon is influenced by multiple groups, and its precise shift requires more advanced analysis for definitive assignment.
- Aliphatic Carbons: The methoxy (-OCH₃) and methyl (-CH₃) carbons will appear in the upfield region of the spectrum, typically around 55-60 ppm and 15-20 ppm, respectively.

Predicted ¹³C NMR Data Summary

Carbon Assignment	Predicted Chemical Shift (δ, ppm)	Carbon Type
C-2	~158 - 162	Quaternary (C)
C-5	~138 - 142	Quaternary (C)
C-4	~133 - 137	Quaternary (C)
C-6	~130 - 134	CH
-CN	~117 - 119	Quaternary (C)
C-3	~114 - 118	CH
C-1	~105 - 110	Quaternary (C)
-OCH ₃	~55 - 60	CH ₃
-CH ₃	~18 - 22	CH ₃

Part 3: Advanced 2D NMR for Unambiguous Structural Verification

While 1D NMR provides a strong foundation, 2D NMR experiments are essential for irrefutable assignment, especially of the quaternary carbons.[2][7] These experiments reveal through-bond correlations between nuclei.

HSQC: Direct Proton-Carbon Correlation

The Heteronuclear Single Quantum Coherence (HSQC) experiment correlates each proton signal with the signal of the carbon to which it is directly attached. This is the most reliable way to assign protonated carbons.

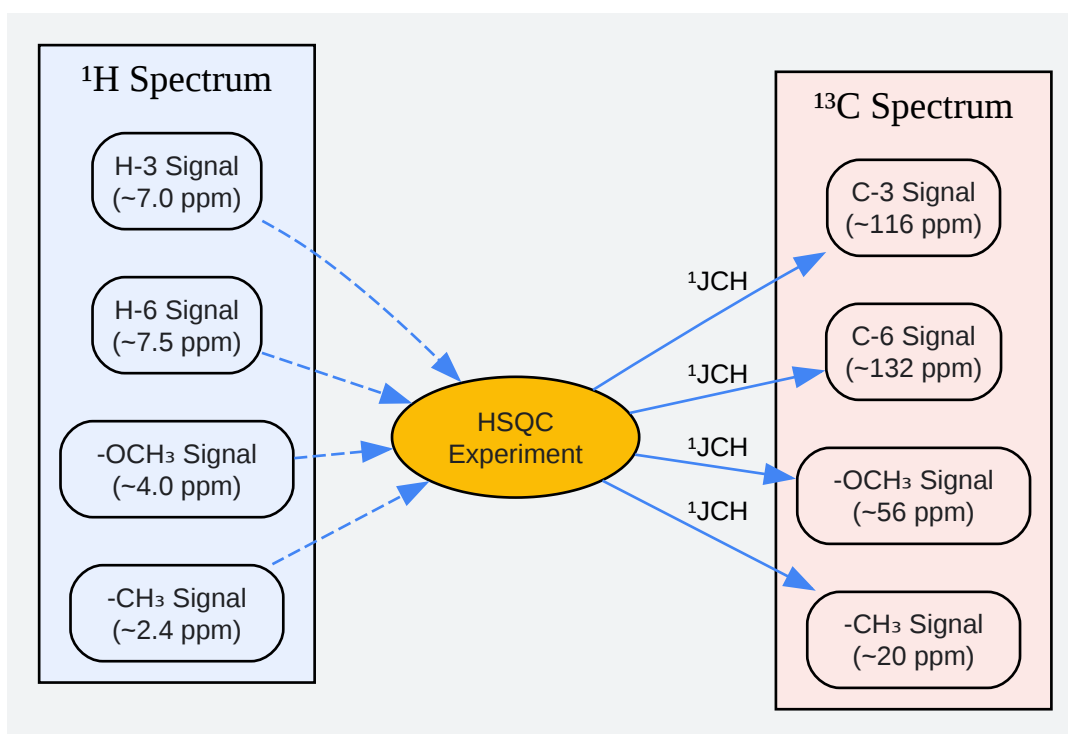

[Click to download full resolution via product page](#)

Figure 2: HSQC workflow showing direct one-bond (^1JCH) correlations.

Expected HSQC Correlations:

- A cross-peak connecting the ^1H signal at ~7.0 ppm to the ^{13}C signal at ~116 ppm, confirming their assignment as H-3 and C-3.

- A cross-peak connecting the ^1H signal at ~ 7.5 ppm to the ^{13}C signal at ~ 132 ppm, confirming their assignment as H-6 and C-6.
- Correlations for the $-\text{OCH}_3$ and $-\text{CH}_3$ groups, definitively linking their respective proton and carbon signals.

HMBC: Mapping the Skeleton via Long-Range Correlations

The Heteronuclear Multiple Bond Correlation (HMBC) experiment is the key to assigning non-protonated (quaternary) carbons. It detects correlations between protons and carbons that are two or three bonds away (^2JCH and ^3JCH).

Need Custom Synthesis?

BenchChem offers custom synthesis for rare earth carbides and specific isotopic labeling.

Email: info@benchchem.com or [Request Quote Online](#).

Sources

- [1. 755027-31-7 Cas No. | 4-Chloro-2-methoxy-5-methylbenzotrile | Matrix Scientific \[matrixscientific.com\]](#)
- [2. researchgate.net \[researchgate.net\]](#)
- [3. azom.com \[azom.com\]](#)
- [4. www2.chem.wisc.edu \[www2.chem.wisc.edu\]](#)
- [5. NMR Spectroscopy of Benzene Derivatives \[moodle.tau.ac.il\]](#)
- [6. chem.libretexts.org \[chem.libretexts.org\]](#)
- [7. sites.esa.ipb.pt \[sites.esa.ipb.pt\]](#)
- To cite this document: BenchChem. [4-Chloro-2-methoxy-5-methylbenzotrile NMR analysis]. BenchChem, [2026]. [Online PDF]. Available at: [\[https://www.benchchem.com/product/b1391815/docs#4-chloro-2-methoxy-5-methylbenzotrile-nmr-analysis\]](https://www.benchchem.com/product/b1391815/docs#4-chloro-2-methoxy-5-methylbenzotrile-nmr-analysis)

Disclaimer & Data Validity:

The information provided in this document is for Research Use Only (RUO) and is strictly not intended for diagnostic or therapeutic procedures. While BenchChem strives to provide accurate protocols, we make no warranties, express or implied, regarding the fitness of this product for every specific experimental setup.

Technical Support: The protocols provided are for reference purposes. Unsure if this reagent suits your experiment?

Need Industrial/Bulk Grade? [Request Custom Synthesis Quote](#)

BenchChem

Our mission is to be the trusted global source of essential and advanced chemicals, empowering scientists and researchers to drive progress in science and industry.

Contact

Address: 3281 E Guasti Rd
Ontario, CA 91761, United States
Phone: (601) 213-4426
Email: info@benchchem.com

[Contact our Ph.D. Support Team for a compatibility check](#)