

Technical Support Center: Optimizing Dipsanoside A Resolution in Complex Mixtures

Author: BenchChem Technical Support Team. **Date:** April 2026

Compound of Interest

Compound Name: *Dipsanoside A*

Cat. No.: *B13905939*

[Get Quote](#)

This technical support center provides researchers, scientists, and drug development professionals with comprehensive troubleshooting guides and frequently asked questions (FAQs) to improve the resolution of **Dipsanoside A** in complex mixtures, typically derived from plants of the *Dipsacus* genus.

Frequently Asked Questions (FAQs)

Q1: What is **Dipsanoside A** and in what types of complex mixtures is it commonly found?

A1: **Dipsanoside A** is a tetracyclic iridoid glucoside, a type of saponin, primarily isolated from the roots of *Dipsacus asper*.^{[1][2]} In its natural source, it exists within a complex mixture of other structurally related compounds, including other iridoid glycosides (e.g., loganin, sweroside, triplastoside A), triterpenoid saponins (e.g., akebiasaponin D), and phenolic acids (e.g., caffeic acid, chlorogenic acid).^{[1][2][3]} The presence of these compounds, often with similar polarities, presents a significant challenge for achieving high-resolution separation of **Dipsanoside A**.

Q2: What are the primary challenges in achieving high resolution of **Dipsanoside A**?

A2: The main challenges in resolving **Dipsanoside A** stem from the chemical complexity of the plant matrix. These challenges include:

- **Co-elution:** Structurally similar iridoid glycosides and triterpenoid saponins often have very close retention times in standard reversed-phase HPLC, leading to overlapping peaks.
- **Peak Tailing:** The presence of free silanol groups on the stationary phase can interact with the polar glycosidic moieties of **Dipsanoside A**, causing peak tailing and reduced resolution.
- **Low Abundance:** **Dipsanoside A** may be a minor component in the extract, making its detection and quantification difficult without efficient separation from more abundant compounds.
- **Matrix Effects:** The presence of numerous other compounds in the extract can interfere with the ionization of **Dipsanoside A** in mass spectrometry-based detection, leading to signal suppression.

Q3: What are the recommended analytical techniques for improving the resolution of **Dipsanoside A**?

A3: For complex mixtures containing **Dipsanoside A**, advanced chromatographic techniques are often necessary to achieve adequate resolution. These include:

- **Two-Dimensional Liquid Chromatography (2D-LC):** This powerful technique significantly increases peak capacity and resolution by employing two different separation mechanisms. A common and effective combination for saponins is Hydrophilic Interaction Chromatography (HILIC) in the first dimension followed by Reversed-Phase Liquid Chromatography (RPLC) in the second dimension.
- **High-Performance Countercurrent Chromatography (HPCCC):** This is a liquid-liquid partition chromatography technique that avoids the use of a solid stationary phase, thereby eliminating issues related to irreversible adsorption and peak tailing. It is particularly well-suited for the preparative isolation of saponins.
- **Optimized High-Performance Liquid Chromatography (HPLC):** While challenging, standard HPLC methods can be optimized by carefully selecting the stationary phase, mobile phase composition, and other parameters to enhance the resolution of **Dipsanoside A**.

Troubleshooting Guides

Poor Resolution in Reversed-Phase HPLC

Symptom	Possible Cause(s)	Troubleshooting Steps & Solutions
Co-eluting Peaks	Insufficient selectivity of the stationary phase. Inappropriate mobile phase composition.	<p>1. Change Stationary Phase: Switch to a column with a different selectivity, such as a phenyl-hexyl or a polar-embedded phase.</p> <p>2. Optimize Mobile Phase:</p> <ul style="list-style-type: none"> - Gradient Optimization: Adjust the gradient slope and time to better separate compounds with similar polarities. - Organic Modifier: Try a different organic modifier (e.g., methanol instead of acetonitrile) as it can alter selectivity. - Additives: Incorporate a small amount of acid (e.g., 0.1% formic acid or acetic acid) to the mobile phase to suppress the ionization of acidic compounds and improve peak shape.[4]
Peak Tailing	Secondary interactions with residual silanol groups on the silica-based stationary phase. Column overload.	<p>1. Use an End-Capped Column: Employ a high-quality, end-capped C18 column to minimize silanol interactions.</p> <p>2. Mobile Phase pH: Adjust the mobile phase pH to be between 2 and 8 for silica-based columns.[5]</p> <p>3. Reduce Sample Load: Decrease the injection volume or sample concentration to avoid overloading the column.</p>

Broad Peaks

Low column efficiency. Extra-column band broadening.

1. Check Column
Performance: Test the column with a standard to ensure it meets performance specifications. Replace if necessary. 2. Minimize Tubing Length: Use shorter and narrower internal diameter tubing between the injector, column, and detector. 3. Optimize Flow Rate: A lower flow rate can sometimes improve peak shape, but may increase analysis time.

Experimental Workflow for Method Development

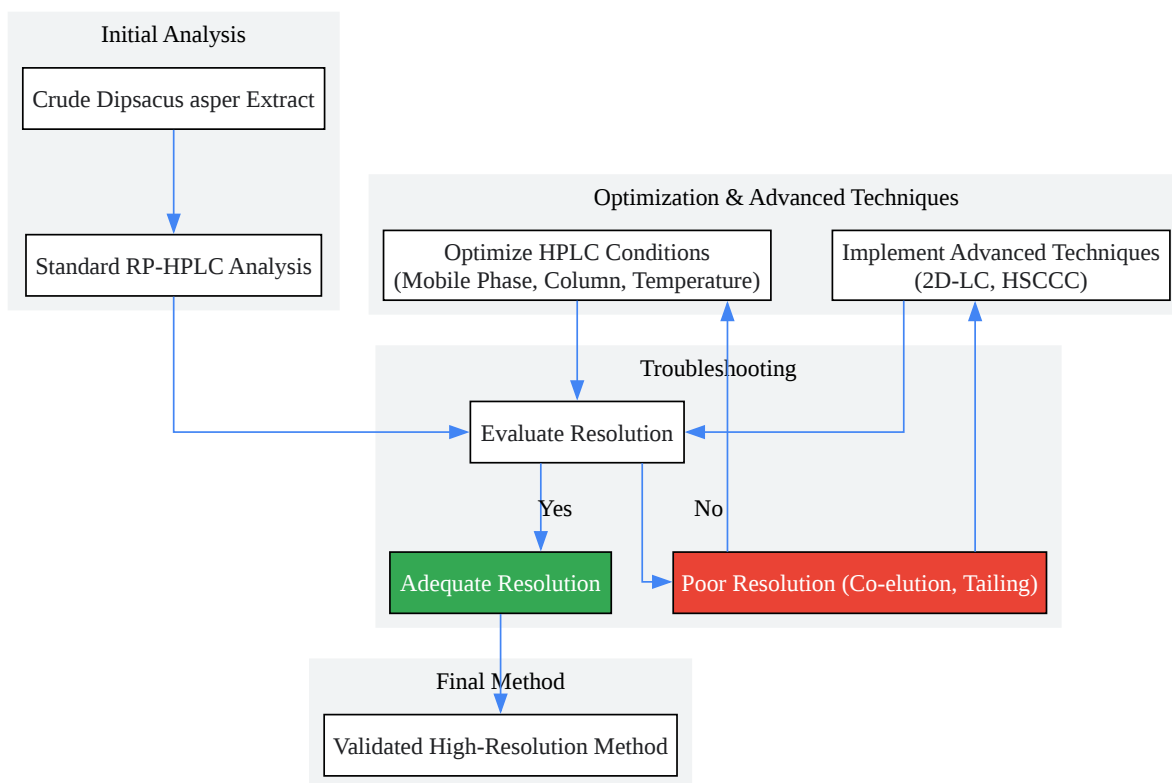

[Click to download full resolution via product page](#)

Caption: A logical workflow for developing a high-resolution method for **Dipsanoside A** analysis.

Quantitative Data on Resolution Improvement

The following table summarizes the typical improvements in resolution when employing advanced chromatographic techniques compared to standard HPLC for the separation of complex saponin mixtures.

Technique	Peak Capacity	Orthogonality	Key Advantages for Dipsanoside A	Reference
Standard HPLC (1D-LC)	~100-300	N/A	Rapid analysis, widely available.	General Knowledge
2D-LC (HILIC x RPLC)	>1000	High (e.g., 0.6-0.9)	Excellent for separating compounds with a wide range of polarities. Significantly reduces co-elution of polar glycosides.	[6][7]
HSCCC	N/A (Preparative)	N/A	No irreversible adsorption, high sample loading capacity, ideal for isolating pure Dipsanoside A.	[8]

Detailed Experimental Protocols

Optimized HPLC Method for Dipsanoside A Analysis

- Column: High-purity, end-capped C18 column (e.g., 4.6 x 250 mm, 5 µm).
- Mobile Phase:
 - A: 0.1% Formic acid in Water
 - B: Acetonitrile
- Gradient: 10-40% B over 30 minutes, then a wash and re-equilibration step.
- Flow Rate: 1.0 mL/min

- Column Temperature: 30°C
- Detection: UV at 210 nm or Mass Spectrometry (ESI, negative ion mode).
- Sample Preparation: Dissolve the dried extract of *Dipsacus asper* in 50% methanol, filter through a 0.45 µm syringe filter.

2D-LC (HILIC x RPLC) Method for High-Resolution Separation

- First Dimension (HILIC):
 - Column: HILIC column (e.g., 2.1 x 100 mm, 1.7 µm).
 - Mobile Phase:
 - A: Acetonitrile with 0.1% Formic Acid
 - B: Water with 0.1% Formic Acid
 - Gradient: High percentage of A to a lower percentage to elute polar compounds.
- Second Dimension (RPLC):
 - Column: C18 column (e.g., 4.6 x 50 mm, 1.8 µm).
 - Mobile Phase:
 - A: Water with 0.1% Formic Acid
 - B: Acetonitrile with 0.1% Formic Acid
 - Gradient: Fast gradient for each fraction from the first dimension.
- Interface: A trapping column and a switching valve are used to transfer fractions from the first to the second dimension.

HSCCC Method for Preparative Isolation of Dipsanoside A

- Two-Phase Solvent System: A suitable system for polar saponins is n-butanol-water or ethyl acetate-n-butanol-water. The ideal partition coefficient (K) for the target compound should be between 0.5 and 2.
- Mode of Operation: Head-to-tail elution.
- Revolution Speed: 800-900 rpm.
- Flow Rate: 1.5-2.0 mL/min.
- Detection: UV detector at 210 nm or an Evaporative Light Scattering Detector (ELSD).

Signaling Pathways and Dipsanoside A

Extracts of *Dipsacus asper*, containing **Dipsanoside A** and other bioactive compounds, have been shown to modulate several key signaling pathways. Understanding these pathways can provide context for the biological activity of the isolated compounds.

ERK1/2 Signaling Pathway

The Extracellular signal-Regulated Kinase (ERK) 1/2 pathway is a crucial signaling cascade involved in cell proliferation, differentiation, and survival.

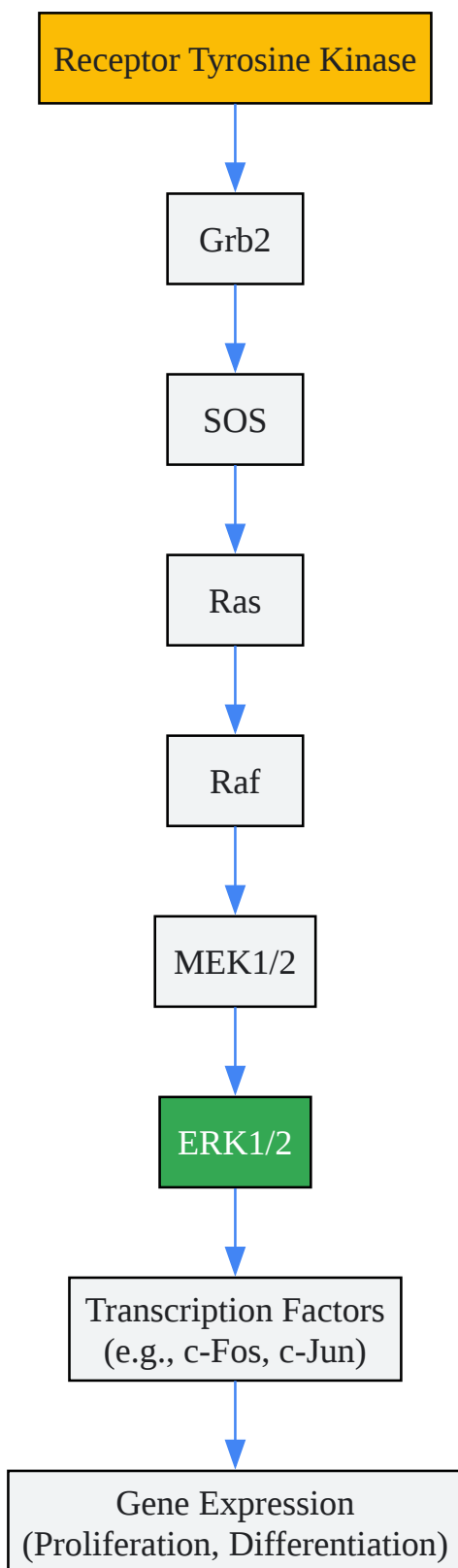

[Click to download full resolution via product page](#)

Caption: The ERK1/2 signaling pathway, a key regulator of cellular processes.

Wnt/ β -catenin Signaling Pathway

The Wnt/ β -catenin pathway plays a critical role in embryonic development and tissue homeostasis. Its dysregulation is often associated with diseases like cancer.

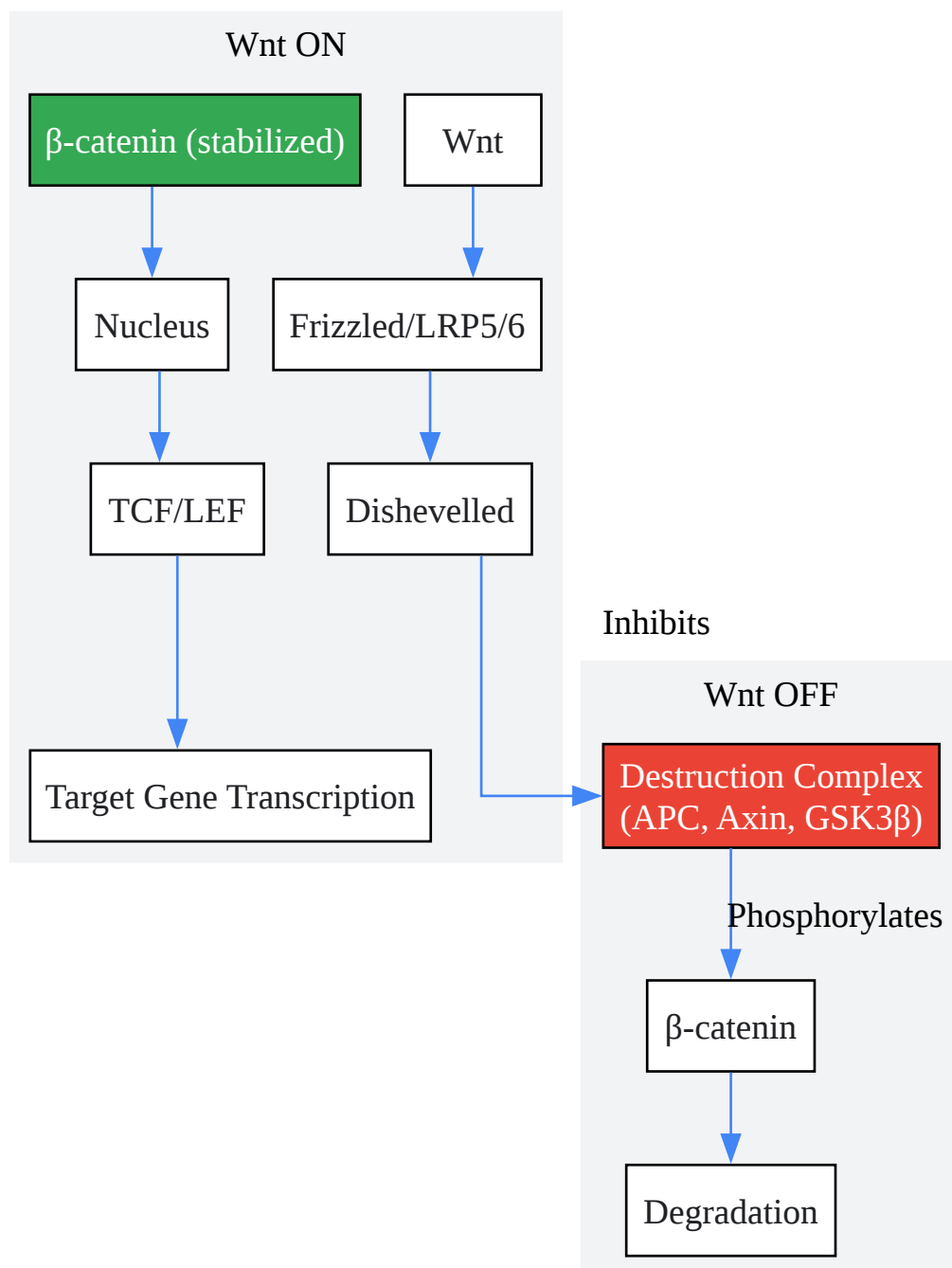

[Click to download full resolution via product page](#)

Caption: The Wnt/ β -catenin signaling pathway in its "OFF" and "ON" states.

Jasmonic Acid (JA) Signaling Pathway

The Jasmonic Acid (JA) signaling pathway is a key regulator of plant defense responses and the biosynthesis of secondary metabolites, including saponins.

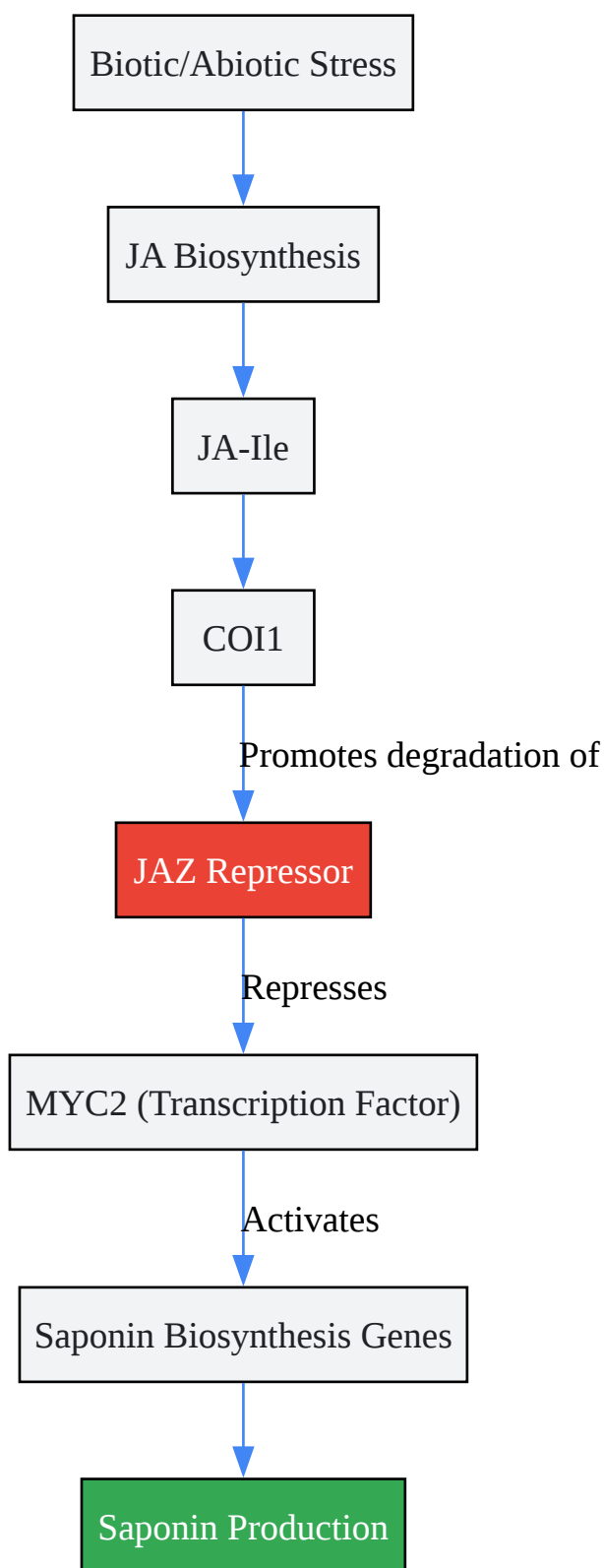

[Click to download full resolution via product page](#)

Caption: The Jasmonic Acid (JA) signaling pathway leading to saponin biosynthesis.

Need Custom Synthesis?

BenchChem offers custom synthesis for rare earth carbides and specific isotopic labeling.

Email: info@benchchem.com or [Request Quote Online](#).

References

- 1. HSCCC Separation of the Two Iridoid Glycosides and Three Phenolic Compounds from *Veronica ciliata* and Their in Vitro Antioxidant and Anti-Hepatocarcinoma Activities - PMC [[pmc.ncbi.nlm.nih.gov](https://pubmed.ncbi.nlm.nih.gov)]
- 2. english.nwipb.cas.cn [english.nwipb.cas.cn]
- 3. [researchgate.net](https://www.researchgate.net) [[researchgate.net](https://www.researchgate.net)]
- 4. Effect of Mobile Phase Additives on the Resolution of Four Bioactive Compounds by RP-HPLC - PMC [[pmc.ncbi.nlm.nih.gov](https://pubmed.ncbi.nlm.nih.gov)]
- 5. hplc.eu [hplc.eu]
- 6. Separation Orthogonality in Liquid Chromatography-Mass Spectrometry for Proteomic Applications: Comparison of 16 Different Two-Dimensional Combinations - PubMed [pubmed.ncbi.nlm.nih.gov]
- 7. [researchgate.net](https://www.researchgate.net) [[researchgate.net](https://www.researchgate.net)]
- 8. Preparative isolation and purification of iridoid glycosides from *Fructus Corni* by high-speed countercurrent chromatography - PMC [[pmc.ncbi.nlm.nih.gov](https://pubmed.ncbi.nlm.nih.gov)]
- To cite this document: BenchChem. [Technical Support Center: Optimizing Dipsanoside A Resolution in Complex Mixtures]. BenchChem, [2026]. [Online PDF]. Available at: [<https://www.benchchem.com/product/b13905939/docs#technical-support-center-optimizing-dipsanoside-a-resolution-in-complex-mixtures>]

Disclaimer & Data Validity:

The information provided in this document is for Research Use Only (RUO) and is strictly not intended for diagnostic or therapeutic procedures. While BenchChem strives to provide accurate protocols, we make no warranties, express or implied, regarding the fitness of this product for every specific experimental setup.

Technical Support: The protocols provided are for reference purposes. Unsure if this reagent suits your experiment?

Need Industrial/Bulk Grade? [Request Custom Synthesis Quote](#)

BenchChem

Our mission is to be the trusted global source of essential and advanced chemicals, empowering scientists and researchers to drive progress in science and industry.

Contact

Address: 3281 E Guasti Rd
Ontario, CA 91761, United States
Phone: (601) 213-4426
Email: info@benchchem.com

[Contact our Ph.D. Support Team for a compatibility check](#)