

Technical Support Center: Synthesis and Purification of Fmoc-4-aminocinnamic acid

Author: BenchChem Technical Support Team. **Date:** May 2026

Compound of Interest

Compound Name: *Fmoc-4-aminocinnamic acid*

CAS No.: 1009806-19-2

Cat. No.: B1390395

[Get Quote](#)

Welcome to the technical support resource for the synthesis of **Fmoc-4-aminocinnamic acid**. This guide is designed for researchers, chemists, and drug development professionals to navigate the common challenges associated with this procedure, with a focus on identifying and removing process-related impurities. Our goal is to provide not just protocols, but the underlying chemical principles to empower you to troubleshoot and optimize your synthesis effectively.

Frequently Asked Questions (FAQs)

Q1: What are the most common byproducts I should expect during the synthesis of Fmoc-4-aminocinnamic acid?

A1: During the synthesis of Fmoc-protected amino acids, several predictable impurities can arise from side reactions.^[1] For **Fmoc-4-aminocinnamic acid**, the primary byproducts include:

- **Fmoc-dipeptide:** The formation of Fmoc-(4-aminocinnamic acid)₂-OH occurs when the activating agent (like Fmoc-Cl) reacts with an already formed molecule of your desired product. This leads to the double insertion of the amino acid during peptide synthesis.[2]
- **β-Alanine Derivatives:** If you are using N-(9-fluorenylmethoxycarbonyloxy)succinimide (Fmoc-OSu) as your protecting agent, a Lossen-type rearrangement can occur, leading to the formation of Fmoc-β-Ala-OH and Fmoc-β-Ala-(4-aminocinnamic acid)-OH.[3] These impurities can cause the unwanted insertion of β-alanine into your peptide sequence.[3]
- **Unreacted 4-aminocinnamic acid:** Incomplete reaction will leave residual starting material in your crude product.[2] This can interfere with coupling efficiencies in subsequent peptide synthesis steps.
- **Hydrolysis Products of the Fmoc Reagent:** Reagents like 9-fluorenylmethyl chloroformate (Fmoc-Cl) are moisture-sensitive and can hydrolyze.[4] The resulting byproducts can complicate purification.
- **Residual Acetic Acid:** If ethyl acetate is used as a solvent during work-up or recrystallization, its hydrolysis can introduce trace amounts of acetic acid.[1] Acetic acid is a potent capping agent in peptide synthesis and can lead to truncated sequences, making its removal critical. [5]

Q2: Why is the purity of my Fmoc-4-aminocinnamic acid so critical for solid-phase peptide synthesis (SPPS)?

A2: The quality of your building blocks directly dictates the quality of your final peptide. Even seemingly minor impurities in your Fmoc-amino acid starting material can have a significant negative impact on the outcome of your SPPS.

- **Chain Termination:** Impurities like acetic acid can act as capping agents, acylating the N-terminal amine of the growing peptide chain and preventing further elongation. This leads to a higher proportion of truncated, difficult-to-remove peptide sequences.[5]
- **Deletion/Insertion Sequences:** Dipeptide or β-alanine impurities will be incorporated into the peptide chain, resulting in peptides with incorrect sequences (double additions or insertions).

[2] These are often difficult to separate from the target peptide due to similar physicochemical properties.[6]

- **Reduced Yield and Complex Purification:** The presence of these byproducts lowers the overall yield of the desired full-length peptide and significantly complicates downstream purification, often requiring multiple chromatographic steps and leading to substantial product loss.[6] Purifying the amino acid raw material beforehand can lead to a greater than 15% increase in final crude peptide purity.[7]

Q3: My crude product is an oil and won't solidify. What is the likely cause and how can I fix it?

A3: Obtaining an oily crude product instead of a solid is a common issue, often caused by the presence of residual solvents or impurities that depress the freezing point.

- **Causality:** The most common culprits are residual solvents from the reaction (e.g., dioxane, acetone) or extraction (e.g., ethyl acetate, dichloromethane).[8] Unreacted reagents or oily byproducts can also contribute.
- **Troubleshooting:**
 - **High-Vacuum Drying:** Ensure your product is dried under a high vacuum for an extended period to remove volatile organic solvents.
 - **Solvent Trituration:** Try stirring or sonicating the oil with a non-polar solvent in which your product is insoluble, but the impurities are soluble. n-Heptane or diethyl ether are excellent choices for this.[9] This process can often induce precipitation or crystallization.
 - **Re-precipitation:** Dissolve the oil in a minimal amount of a good solvent (e.g., ethyl acetate) and precipitate it by adding a large volume of a poor solvent (e.g., hexane).

Troubleshooting Guide: From Crude Product to Pure Material

This section addresses specific issues you might encounter post-synthesis and during purification.

Problem 1: HPLC analysis of my crude product shows multiple major peaks.

- **Diagnosis:** This indicates significant byproduct formation. The identity of the peaks can be inferred from their retention times (impurities are often more or less polar than the product) and confirmed with mass spectrometry.
- **Logical Workflow:** A multi-step purification approach is necessary. The general workflow should be: Aqueous Work-up → Recrystallization → Column Chromatography (if needed).

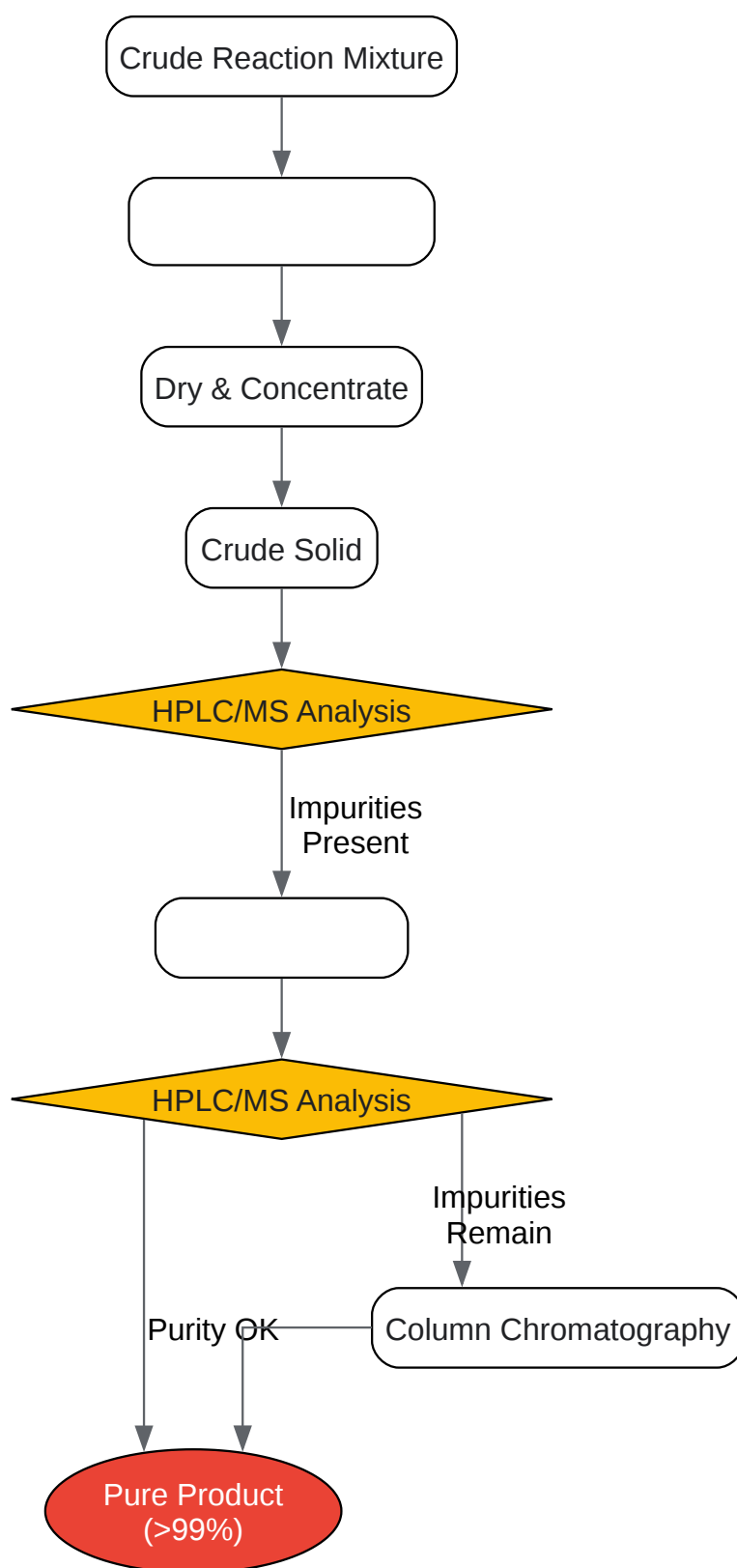

[Click to download full resolution via product page](#)

Caption: General purification workflow for **Fmoc-4-aminocinnamic acid**.

Protocol 1: Standard Aqueous Work-up

- Causality: This initial step is designed to remove water-soluble reagents (e.g., sodium carbonate), salts (e.g., triethylammonium chloride), and unreacted Fmoc-Cl/Fmoc-OSu through hydrolysis and extraction.[8] Acidification protonates the carboxylate, rendering the desired product soluble in an organic solvent.[8]
- Step-by-Step Methodology:
 - Dilute the reaction mixture with a significant volume of water.
 - Perform an initial wash with a water-immiscible organic solvent like diethyl ether to remove highly non-polar byproducts and any unreacted Fmoc-Cl.[8] Discard the organic layer.
 - Cool the aqueous layer in an ice bath and acidify to a pH of 2-3 using dilute hydrochloric acid (e.g., 1M HCl). Your product should precipitate as a white solid.
 - Extract the precipitated product into an organic solvent such as ethyl acetate (perform 3 separate extractions).[10]
 - Combine the organic extracts and wash with brine to remove residual water.
 - Dry the organic layer over anhydrous sodium sulfate or magnesium sulfate, filter, and concentrate under reduced pressure to yield the crude solid.[8]

Problem 2: Recrystallization fails to significantly improve purity.

- Diagnosis: This suggests that the primary impurities have solubility properties very similar to your target compound in the chosen solvent system. It could also mean the solvent system is not optimal.
- Solution:
 - Solvent System Screening: The key to successful recrystallization is identifying a solvent (or solvent pair) where the compound is sparingly soluble at room temperature but highly

soluble when hot. For Fmoc-amino acids, common systems include ethyl acetate/hexane, toluene, or ethanol/water mixtures.[7][8][11]

- Consider an Alternative Purification Method: If multiple recrystallization attempts fail, column chromatography is the next logical step.[8]

Protocol 2: Recrystallization from Toluene

- Causality: Toluene is effective for many Fmoc-amino acids as it can effectively solubilize the compound at elevated temperatures while leaving more polar or certain non-polar impurities either insoluble or in the mother liquor upon cooling.[7]
- Step-by-Step Methodology:
 - Place the crude **Fmoc-4-aminocinnamic acid** in a flask.
 - Add a volume of toluene (e.g., 6 mL per gram of crude product).[7]
 - Heat the mixture to 50-60°C with stirring until the solid is fully dissolved. Add more solvent in small portions if necessary to achieve full dissolution.
 - Once dissolved, allow the solution to cool slowly to room temperature. Slow cooling is crucial for forming well-defined crystals.
 - Further cool the flask in an ice bath for 1-2 hours to maximize precipitation.[7]
 - Collect the crystals by vacuum filtration, washing the filter cake with a small amount of cold toluene.
 - Dry the purified crystals under high vacuum at a moderate temperature (e.g., 40-50°C) to remove all residual solvent.[7]

Table 1: Troubleshooting Summary

Observed Issue	Potential Cause(s)	Suggested Action(s)	Primary Byproduct Targeted
Oily Crude Product	Residual Solvents, Oily Impurities	High-vacuum drying, Trituration with n- heptane.	Unreacted reagents, solvent traces.
Multiple HPLC Peaks	Incomplete reaction, Side reactions.	Perform full purification workflow (Work-up, Recrystallization).	Dipeptides, Free amino acid.
New peak with +~222 Da	Dibenzofulvene adduct formation.	Ensure sufficient base (e.g., piperidine) is used during deprotection steps in SPPS to scavenge dibenzofulvene.[12]	Dibenzofulvene adducts.
Recrystallization Ineffective	Impurities have similar solubility.	Screen different solvent systems (e.g., Ethyl Acetate/Hexane), Proceed to column chromatography.	Dipeptides, β -alanine derivatives.

Mechanistic Insight: Formation of Key Byproducts

Understanding how impurities are formed is key to preventing them. The diagram below illustrates the desired reaction alongside two major side reactions.

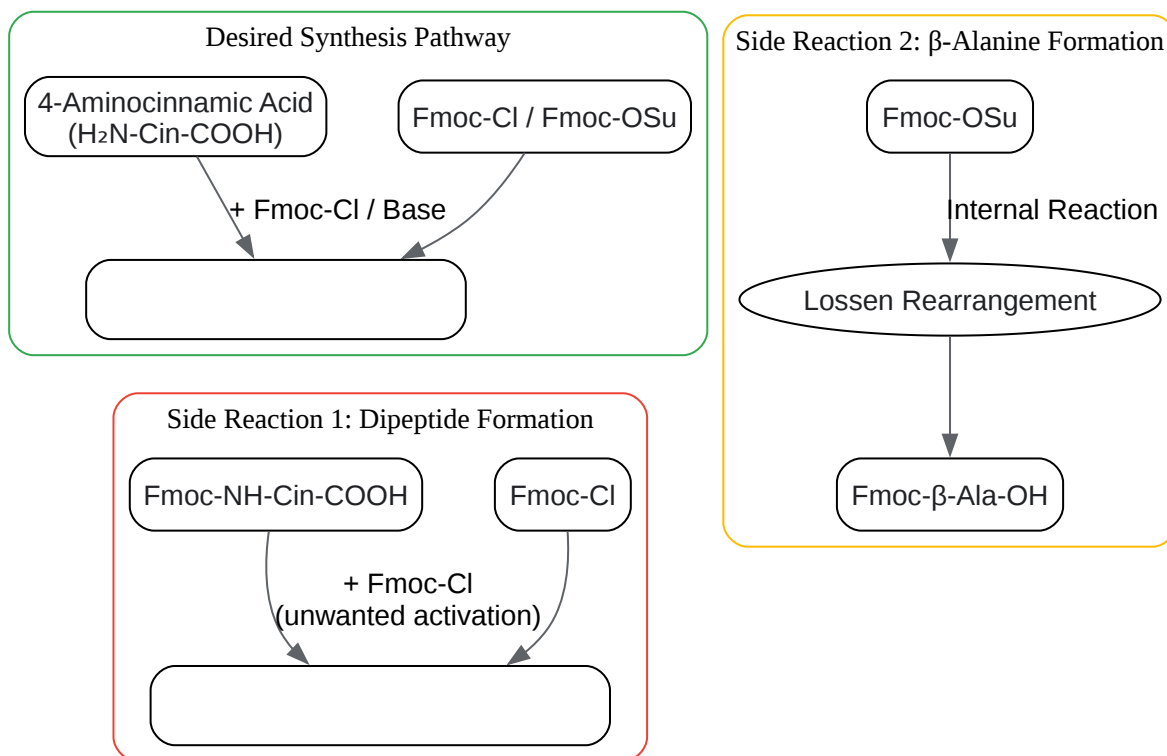

[Click to download full resolution via product page](#)

Caption: Key reaction pathways in the synthesis of **Fmoc-4-aminocinnamic acid**.

References

- BenchChem. (2025). A Comprehensive Technical Guide to Fmoc-Protected Amino Acids in Peptide Synthesis.
- Creative Peptides. (n.d.).
- Merck Millipore. (n.d.).
- Sigma-Aldrich. (n.d.). Novabiochem® Fmoc-Amino Acids.
- Fields, G. B. (1994). Methods for Removing the Fmoc Group. In M. W. Pennington & B. M. Dunn (Eds.), Peptide Synthesis Protocols (Vol. 35, pp. 17-34). Humana Press.
- Springer Nature. (n.d.). Methods for Removing the Fmoc Group.
- BenchChem. (n.d.). Purity issues and common impurities in Fmoc-D-Arg(Pbf)-OH.

- Guryanov, I., et al. (2018). COMPARISON OF REAGENTS FOR FMOC-GROUP REMOVAL FROM GROWING PEPTIDE CHAIN IN THE SOLID-PHASE PEPTIDE SYNTHESIS.
- Organic Letters. (2022). Development of Fmoc-Protected Bis-Amino Acids toward Automated Synthesis of Highly Functionalized Spiroligomers.
- National Institutes of Health. (2022). Optimized Fmoc-Removal Strategy to Suppress the Traceless and Conventional Diketopiperazine Formation in Solid-Phase Peptide Synthesis. PMC.
- Oxford Academic. (n.d.). Purification of large peptides using chemoselective tags.
- Sethi, M. K., et al. (2020). Impact of purification of fmoc-amino acids on peptide purity in solid phase peptide synthesis. Asian Journal of Pharmaceutical Analysis and Medicinal Chemistry, 8(3), 95-104.
- ACS Sustainable Chemistry & Engineering. (2021). Fmoc-Removal with Pyrrolidine Expands the Available Solvent Space in Green Solid-Phase Peptide Synthesis.
- Hlebowicz, E., et al. (2009). Identification of Fmoc- β -Ala-OH and Fmoc- β -Ala-amino acid-OH as new impurities in Fmoc-protected amino acid derivatives. Journal of Peptide Science, 15(8), 534-540.
- Total Synthesis. (n.d.). Fmoc Protecting Group: Fmoc Protection & Deprotection Mechanism.
- ChemPep. (n.d.). Fmoc Solid Phase Peptide Synthesis.
- National Institutes of Health. (2022). Efficient Fmoc-Protected Amino Ester Hydrolysis Using Green Calcium(II) Iodide as a Protective Agent.
- ResearchGate. (n.d.). The hydrolysis reaction of FMOC-Cl.
- Google Patents. (n.d.). CN103373940A - Novel process for synthesizing N-FMOC-amino acid crude product of non-active side chain.
- ResearchGate. (2014). How to get (or crystallize)

Need Custom Synthesis?

BenchChem offers custom synthesis for rare earth carbides and specific isotopic labeling.

Email: info@benchchem.com or [Request Quote Online](#).

Sources

- [1. merckmillipore.com](https://www.merckmillipore.com) [[merckmillipore.com](https://www.merckmillipore.com)]
- [2. Peptide Impurities & Solutions - Creative Peptides](https://www.creative-peptides.com) [[creative-peptides.com](https://www.creative-peptides.com)]
- [3. researchgate.net](https://www.researchgate.net) [[researchgate.net](https://www.researchgate.net)]
- [4. researchgate.net](https://www.researchgate.net) [[researchgate.net](https://www.researchgate.net)]

- [5. pdf.benchchem.com \[pdf.benchchem.com\]](#)
- [6. academic.oup.com \[academic.oup.com\]](#)
- [7. ajpamc.com \[ajpamc.com\]](#)
- [8. pdf.benchchem.com \[pdf.benchchem.com\]](#)
- [9. researchgate.net \[researchgate.net\]](#)
- [10. total-synthesis.com \[total-synthesis.com\]](#)
- [11. CN103373940A - Novel process for synthesizing N-FMOC-amino acid crude product of non-active side chain - Google Patents \[patents.google.com\]](#)
- [12. chempep.com \[chempep.com\]](#)
- To cite this document: BenchChem. [Technical Support Center: Synthesis and Purification of Fmoc-4-aminocinnamic acid]. BenchChem, [2026]. [Online PDF]. Available at: [<https://www.benchchem.com/product/b1390395/docs#technical-support-center-synthesis-and-purification-of-fmoc-4-aminocinnamic-acid>]

Disclaimer & Data Validity:

The information provided in this document is for Research Use Only (RUO) and is strictly not intended for diagnostic or therapeutic procedures. While BenchChem strives to provide accurate protocols, we make no warranties, express or implied, regarding the fitness of this product for every specific experimental setup.

Technical Support: The protocols provided are for reference purposes. Unsure if this reagent suits your experiment?

Need Industrial/Bulk Grade? [Request Custom Synthesis Quote](#)

BenchChem

Our mission is to be the trusted global source of essential and advanced chemicals, empowering scientists and researchers to drive progress in science and industry.

Contact

Address: 3281 E Guasti Rd

Ontario, CA 91761, United States

Phone: (601) 213-4426

Email: info@benchchem.com

Contact our Ph.D. Support Team for a compatibility check