

# Technical Support Center: Fmoc-DL-Thyronine Coupling Optimization

**Author:** BenchChem Technical Support Team. **Date:** May 2026

## Compound of Interest

Compound Name: *Fmoc-DL-thyronine*

CAS No.: 1452575-06-2

Cat. No.: B1390333

[Get Quote](#)

Topic: Troubleshooting Incomplete Coupling of **Fmoc-DL-Thyronine** Ticket ID: #THY-SPPS-001 Assigned Scientist: Senior Application Specialist, Peptide Chemistry Division

## Executive Summary: The Thyronine Challenge

Coupling **Fmoc-DL-Thyronine** (Fmoc-Thy-OH) presents a "perfect storm" of synthetic challenges in Solid Phase Peptide Synthesis (SPPS). Unlike standard amino acids, Thyronine possesses a bulky diphenyl ether side chain that introduces severe steric hindrance and significant hydrophobicity. Furthermore, the commercial availability of this building block as a racemic (DL) mixture often lacking phenolic protection requires specific handling to prevent side reactions (O-acylation) and misinterpretation of analytical data (diastereomeric splitting).

This guide addresses the three primary barriers to success: Solubility, Steric Activation, and Chemo-selectivity.

## Phase 1: Diagnostic & Troubleshooting (Q&A)

## Q1: "My coupling yield is low (<50%) despite using standard HBTU protocols. Is the reagent bad?"

A: The reagent is likely fine, but HBTU is insufficient for this specific molecule. Root Cause: The bulky diphenyl ether side chain of Thyronine creates a "steric wall" around the alpha-amine. Standard reagents like HBTU/TBTU generate an active ester (OBt) that is not reactive enough to overcome this barrier before hydrolysis or other side reactions occur. Solution: Switch to HATU or COMU. These reagents generate more reactive species (OAt or Oxyma esters) that accelerate the reaction kinetics significantly, effectively "forcing" the coupling through the steric bulk.

## Q2: "The reaction mixture turns cloudy or forms a gel immediately upon addition to the resin."

A: You are facing the Solubility & Aggregation Barrier. Root Cause: Fmoc-Thy-OH is highly hydrophobic. Standard SPPS concentration (0.1–0.2 M in DMF) often leads to precipitation or "on-resin aggregation" (beta-sheet formation), where the peptide chains collapse on themselves, burying the N-terminus. Solution:

- Reduce Concentration: Dissolve Fmoc-Thy-OH at 0.05 M.
- Solvent Cocktail: Use a mixture of DMF/NMP (1:1) or add DMSO (10-20%) to the coupling mixture.
- Chaotropic Salts: Add 0.8 M LiCl or 4 M KSCN to the coupling buffer to disrupt hydrogen bonding.

## Q3: "I see two distinct peaks in my HPLC trace with identical mass. Is this a deletion sequence?"

A: Likely not. This is an artifact of the DL-stereochemistry. Root Cause: You are using **Fmoc-DL-Thyronine**. Even if the coupling is 100% successful, you are introducing a racemic center into a chiral peptide chain. This creates diastereomers (e.g., L-L-L-L-Thy-L... and L-L-L-D-Thy-L...), which have different physical properties and often separate on C18 columns. Action: Verify mass. If both peaks have the target mass, the coupling worked. Do not try to "optimize" this away unless you switch to an enantiopure starting material (Fmoc-L-Thy-OH).

## Q4: "My mass spec shows a +Mass shift corresponding to an extra Thyronine (+AA). Is this double coupling?"

A: This is likely Phenolic O-Acylation. Root Cause: If your Fmoc-Thy-OH has an unprotected phenolic hydroxyl group (common in commercial sources), high pH (excess base) can deprotonate the phenol, making it nucleophilic. It then attacks the activated amino acid, forming an ester bond (branching) on the side chain. Solution:

- **Stoichiometry Control:** Use exactly 1.0 equivalent of base (DIPEA/NMM) relative to the amino acid.
- **Weaker Base:** Switch to Sym-collidine (TMP) instead of DIPEA. Collidine is strong enough to drive acylation but too sterically hindered to effectively deprotonate the phenol.

## Phase 2: Optimized Protocols

### Protocol A: The "Power Coupling" Method (Manual/Automated)

Recommended for standard synthesis scales (0.05 - 0.25 mmol).

Parameter	Standard Condition	Optimized Thyronine Condition
Solvent	DMF	NMP or DMF with 20% DMSO
Concentration	0.2 M	0.05 M - 0.1 M (Max)
Activator	HBTU / TBTU	HATU or COMU
Base	DIPEA (2.0 eq)	Sym-Collidine (1.0 - 1.2 eq)
Time	30 - 60 min	2 x 2 hours (Double Couple)
Temperature	RT	50°C (Microwave or Water bath)

Step-by-Step Workflow:

- Swelling: Swell resin in DMF/DCM (1:1) for 20 mins. Drain.
- Dissolution: Dissolve Fmoc-DL-Thy-OH (3.0 eq) and HATU (2.9 eq) in minimum NMP.
- Activation: Add Sym-collidine (3.0 eq) immediately before adding to resin. Do not pre-activate for >2 mins to avoid racemization of the activated ester.
- Coupling: Shake/Vortex for 2 hours. If heating, maintain 50°C.
- Re-Coupling: Drain. Repeat steps 2-4 with fresh reagents.
- Capping: Perform an acetylation step (Acetic Anhydride/Pyridine) to terminate any unreacted chains.

## Protocol B: The "Aggregation Breaker" Wash

Use this if the resin looks "clumped" or "shrunken" before the Thyronine step.

- Prepare Buffer: 0.8 M LiCl in DMF.
- Wash: After Fmoc removal of the previous residue, wash resin with LiCl buffer (3 x 2 min).
- Coupling: Perform the coupling reaction in the presence of the LiCl buffer (or add solid LiCl to the coupling mixture).

## Phase 3: Visualizing the Logic

### Diagram 1: Troubleshooting Decision Tree

Caption: Logical flow for diagnosing Fmoc-Thyronine coupling failures based on observable symptoms.

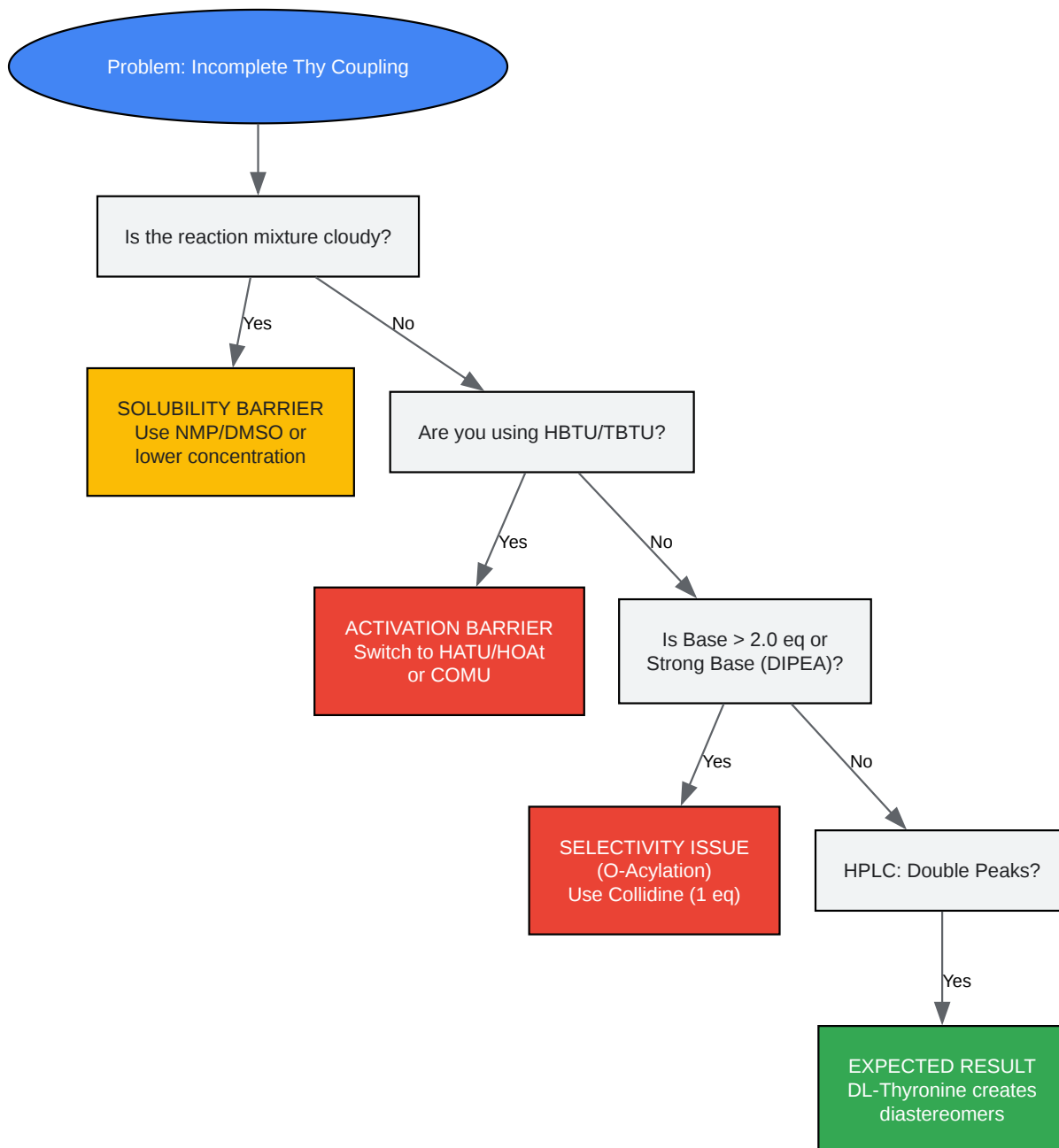

[Click to download full resolution via product page](#)

## Diagram 2: Mechanism of O-Acylation (The "Hidden" Failure)

Caption: Mechanism showing how excess base leads to side-chain esterification on unprotected Thyronine.

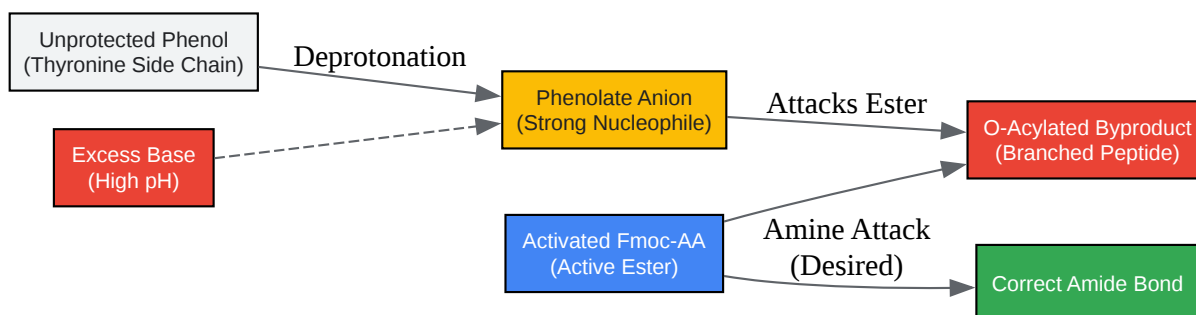

[Click to download full resolution via product page](#)

## Phase 4: Validation & Quality Control

Do not rely solely on the Kaiser Test (Ninhydrin). The bulky Thyronine residue can sterically hinder the ninhydrin reaction, leading to false negatives (appearing colorless even when coupling is incomplete).

Recommended Validation Methods:

- The Chloranil Test: More sensitive for secondary amines and sterically hindered primary amines. A blue color indicates free amines (incomplete coupling).
- Micro-Cleavage: Remove a small amount of resin (2-5 mg), cleave with TFA/TIS/H<sub>2</sub>O (95:2.5:2.5) for 30 mins, and analyze via LC-MS. This is the only definitive way to distinguish between incomplete coupling, O-acylation, and diastereomer formation.

## References

- Albericio, F., & Carpino, L. A. (1997). Coupling reagents and activation strategies. *Methods in Enzymology*, 289, 104-126.

- Establishes HATU/HOAt as the gold standard for hindered couplings.
- Isidro-Llobet, A., et al. (2009). Amino acid-protecting groups. *Chemical Reviews*, 109(6), 2455-2504.
  - Discusses the necessity of side-chain protection and risks of O-acyl
- Paradís-Bas, M., et al. (2016). The "Magic Mixture" and other chaotropic additives for the synthesis of difficult sequences. *Methods in Molecular Biology*, 1348, 1-14.
  - Source for the LiCl and solvent cocktail protocols to overcome aggreg
- Sigma-Aldrich (Merck). "Cleavage and Deprotection Protocols for SPPS."
  - Standard protocols for resin handling and micro-cleavage valid
- [To cite this document: BenchChem. \[Technical Support Center: Fmoc-DL-Thyronine Coupling Optimization\]. BenchChem, \[2026\]. \[Online PDF\]. Available at: \[https://www.benchchem.com/product/b1390333/docs#technical-support-center-fmoc-dl-thyronine-coupling-optimization\]](https://www.benchchem.com/product/b1390333/docs#technical-support-center-fmoc-dl-thyronine-coupling-optimization)

---

### Disclaimer & Data Validity:

The information provided in this document is for Research Use Only (RUO) and is strictly not intended for diagnostic or therapeutic procedures. While BenchChem strives to provide accurate protocols, we make no warranties, express or implied, regarding the fitness of this product for every specific experimental setup.

**Technical Support:** The protocols provided are for reference purposes. Unsure if this reagent suits your experiment?

**Need Industrial/Bulk Grade?** [Request Custom Synthesis Quote](#)

# BenchChem

Our mission is to be the trusted global source of essential and advanced chemicals, empowering scientists and researchers to drive progress in science and industry.

## Contact

Address: 3281 E Guasti Rd

Ontario, CA 91761, United States

Phone: (601) 213-4426

Email: [info@benchchem.com](mailto:info@benchchem.com)

[Contact our Ph.D. Support Team for a compatibility check](#)