

Technical Guide: Mechanism of Action for Substituted Thiazole Compounds

Author: BenchChem Technical Support Team. **Date:** May 2026

Compound of Interest

Compound Name: 2-(Methoxymethyl)-1,3-thiazole-4-carbaldehyde
CAS No.: 854754-21-5
Cat. No.: B1390205

[Get Quote](#)

Executive Summary

The thiazole ring (

) is a privileged scaffold in medicinal chemistry, distinguished by its

-excessive nature and ability to engage in diverse non-covalent interactions (hydrogen bonding,

-

stacking, and sulfur

-hole bonding). This guide dissects the mechanistic versatility of substituted thiazoles, moving beyond generic descriptions to specific molecular targets: microtubule destabilization (oncology), kinase modulation (oncology), and DNA gyrase inhibition (antimicrobial).

Part 1: Structural Pharmacophore & SAR Logic

The biological efficacy of thiazole is dictated by substitution patterns at the C2, C4, and C5 positions. The ring acts as a bioisostere for pyridine or benzene but offers unique electronic properties due to the sulfur atom's lone pairs and aromaticity.

The Core Scaffold

- **C2 Position (Nucleophilic/Basic):** The most common site for introducing amine, amide, or hydrazine linkers. These groups often serve as hydrogen bond donors/acceptors within enzyme active sites (e.g., the ATP-binding pocket of kinases).
- **C4 Position (Lipophilic/Aromatic):** Substitutions here, particularly bulky aryl groups (e.g., 3,4,5-trimethoxyphenyl), are critical for mimicking the pharmacophore of natural products like combretastatin A-4 (CA-4), enabling tubulin binding.
- **C5 Position (Electronic Tuning):** Electron-withdrawing groups (halogens, nitro) or small alkyl groups at C5 modulate the pKa of the ring nitrogen and influence metabolic stability.

Visualization: SAR Decision Tree

The following diagram illustrates the logical flow for optimizing thiazole derivatives based on the desired therapeutic target.

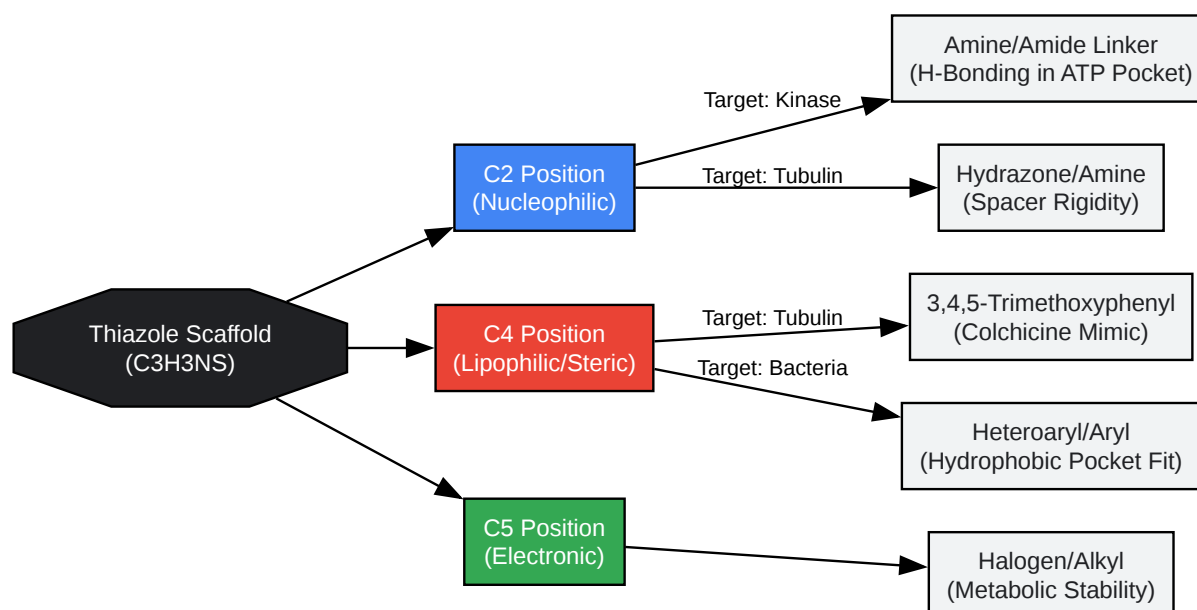

[Click to download full resolution via product page](#)

Caption: SAR optimization logic for thiazole derivatives targeting Kinases, Tubulin, or DNA Gyrase.

Part 2: Oncology Mechanisms (Tubulin & Kinases)

Tubulin Polymerization Inhibition

Many 2,4-disubstituted thiazoles function as Microtubule Destabilizing Agents (MDAs).

- Mechanism: They bind to the colchicine-binding site on -tubulin.
- Causality: Binding prevents the curved-to-straight conformational change required for tubulin dimers to polymerize into microtubules.
- Outcome: This blockade arrests the cell cycle at the G2/M phase (mitosis), leading to mitotic catastrophe and apoptosis.[1]
- Key Structural Feature: The "cis-locked" conformation. The thiazole ring restricts rotation similar to the cis-double bond in Combretastatin A-4, maintaining the necessary geometry to fit the hydrophobic pocket of -tubulin [1, 5].

Kinase Inhibition (Src/Abl)

Dasatinib is the archetype for thiazole-based kinase inhibition.

- Mechanism: It functions as an ATP-competitive inhibitor.
- Molecular Interaction: The thiazole nitrogen acts as a hydrogen bond acceptor for the amide nitrogen of Met318 (in c-Src) or Met341 (in Abl). The 2-amino group acts as a hydrogen bond donor to the carbonyl oxygen of the "gatekeeper" residue (Thr315 in Abl) [9, 10].
- Significance: This dual-anchoring locks the kinase in an inactive conformation.

Visualization: Tubulin Inhibition Pathway

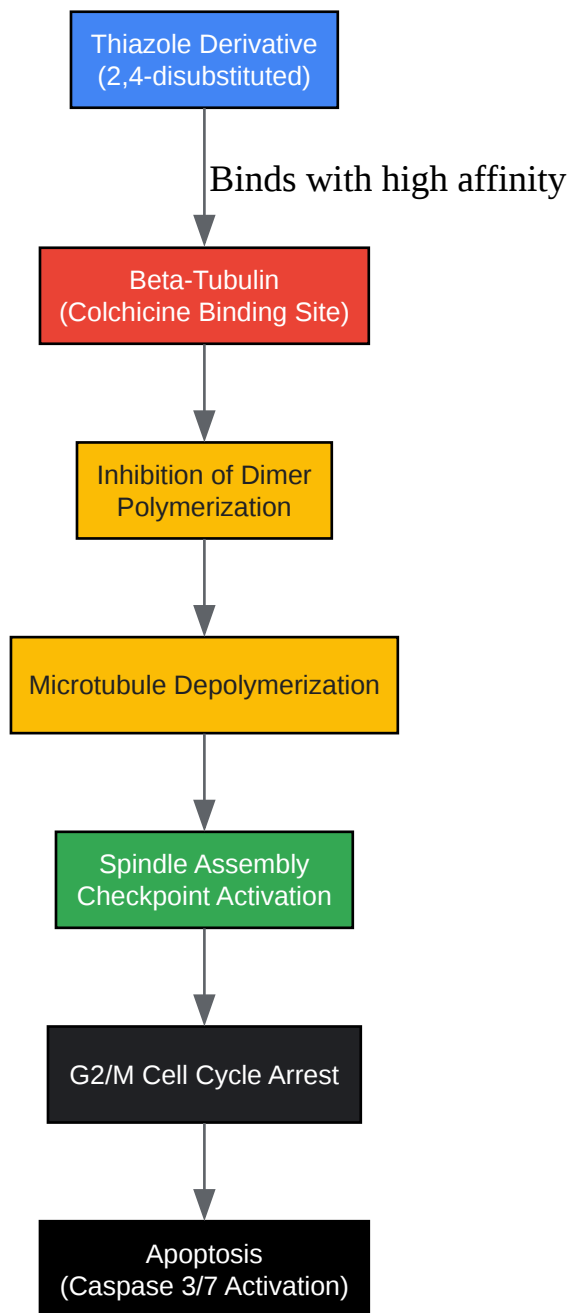

[Click to download full resolution via product page](#)

Caption: Mechanistic cascade of thiazole-induced microtubule destabilization leading to apoptosis.

Part 3: Antimicrobial Mechanism (DNA Gyrase)

Unlike fluoroquinolones which target the GyrA subunit (DNA cleavage/reunion), thiazole derivatives predominantly target the GyrB subunit of bacterial DNA gyrase [2, 6].^[2]

- Target: The ATP-binding pocket of GyrB.^[2]
- Mechanism: Competitive inhibition of ATP hydrolysis. The thiazole ring occupies the pocket, preventing the energy transduction required for DNA supercoiling.
- Resistance Evasion: Because they target GyrB rather than the fluoroquinolone-target GyrA, thiazoles retain activity against many quinolone-resistant strains (e.g., MRSA, VRE).

Part 4: Experimental Protocols

Synthesis: Hantzsch Thiazole Reaction

This is the industry-standard method for generating the thiazole core. It is self-validating because the product typically precipitates out of the reaction mixture upon neutralization.

Protocol:

- Reactants: Combine 1.0 equivalent of an -haloketone (e.g., 2-bromoacetophenone) and 1.0 equivalent of a thioamide (e.g., thiourea) in ethanol or methanol (10 mL/mmol).
- Reaction: Reflux the mixture for 1-2 hours. Monitor via TLC (Mobile phase: 30% Ethyl Acetate in Hexane).
- Validation: The formation of the intermediate thiazolium hydrobromide salt is often visible as a solid.
- Workup: Cool to room temperature. Neutralize with 10% aqueous sodium carbonate () or ammonium hydroxide.
 - Why? The free base thiazole is less soluble in water than the salt, forcing precipitation.
- Purification: Filter the precipitate, wash with water (to remove inorganic salts), and recrystallize from ethanol [7, 8].

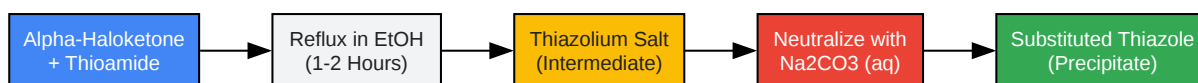

[Click to download full resolution via product page](#)

Caption: Workflow for the Hantzsch Thiazole Synthesis.

Bioassay: Tubulin Polymerization Assay

To verify the mechanism described in Section 2.1, a fluorescence-based polymerization assay is required.

Protocol:

- Reagents: Purified porcine brain tubulin (>99%), GTP (1 mM), and fluorescent reporter (DAPI or specialized kit).
- Control Setup:
 - Negative Control: DMSO (vehicle).
 - Positive Control (Destabilizer): Colchicine (5 μ M).
 - Positive Control (Stabilizer): Paclitaxel (5 μ M) - Crucial for distinguishing mechanism.
- Procedure:
 - Incubate tubulin (2 mg/mL) with the test thiazole compound (various concentrations) at 37°C in PEM buffer.
 - Measure fluorescence excitation/emission (e.g., 360/450 nm) every 60 seconds for 60 minutes.
- Data Analysis: Plot Relative Fluorescence Units (RFU) vs. Time.
 - Interpretation: A reduction in maximum fluorescence (V_{max}) and a decrease in the slope of the growth phase compared to vehicle indicates inhibition of polymerization [1, 5].

Quantitative Data Summary (Representative)

Compound Class	Target	Primary MoA	Representative IC50 (μM)	Reference Standard
2,4-Diarylthiazole	Tubulin (-subunit)	Polymerization Inhibition	0.05 - 2.5	Combretastatin A-4
2-Aminothiazole	Src/Abl Kinase	ATP Competition	< 0.001 (nM range)	Dasatinib
Thiazole-Hydrazone	DNA Gyrase (GyrB)	ATPase Inhibition	4.0 - 15.0	Novobiocin

References

- Synthesis and Molecular Docking Study of New Thiazole Derivatives as Potential Tubulin Polymerization Inhibitors Source: National Institutes of Health (NIH) / PMC URL:[[Link](#)]
- Design, synthesis, and SAR of novel thiazole-based antimicrobials targeting DNA gyrase Source: Hospital Pharmacy Journal URL:[[Link](#)]
- The Potential of Thiazole Derivatives as Antimicrobial Agents Source: MDPI (Molecules) URL:[[Link](#)]
- Synthesis of New Thiazole-Privileged Chalcones as Tubulin Polymerization Inhibitors Source: MDPI (Pharmaceuticals) URL:[[Link](#)]
- Design, synthesis and biological evaluation of novel thiazole-naphthalene derivatives as potential anticancer agents Source: NIH / PubMed Central URL:[[Link](#)]
- Computational Drug Design and Docking Studies of Thiazole Derivatives Targeting Bacterial DNA Gyrase Source: ResearchGate URL:[[Link](#)]
- Hantzsch Thiazole Synthesis Protocol Source: Chem Help Asap URL:[[Link](#)]
- Thiazole Synthesis - Organic Chemistry Portal Source: Organic Chemistry Portal URL:[[Link](#)]

- Dasatinib (BMS-354825) as a Potent pan-Src Kinase Inhibitor Source:[3] ACS Publications (Journal of Medicinal Chemistry) URL:[[Link](#)]
- New pyrazolyl-thiazolidinone/thiazole derivatives as celecoxib/dasatinib analogues Source: NIH / PubMed Central URL:[[Link](#)]

Need Custom Synthesis?

BenchChem offers custom synthesis for rare earth carbides and specific isotopic labeling.

Email: info@benchchem.com or [Request Quote Online](#).

Sources

- 1. Design, synthesis and biological evaluation of novel thiazole-naphthalene derivatives as potential anticancer agents and tubulin polymerisation inhibitors - PMC [[pmc.ncbi.nlm.nih.gov](https://pubmed.ncbi.nlm.nih.gov)]
- 2. [researchgate.net](https://www.researchgate.net) [[researchgate.net](https://www.researchgate.net)]
- 3. pubs.acs.org [pubs.acs.org]
- To cite this document: BenchChem. [Technical Guide: Mechanism of Action for Substituted Thiazole Compounds]. BenchChem, [2026]. [Online PDF]. Available at: [<https://www.benchchem.com/product/b1390205/docs#technical-guide-mechanism-of-action-for-substituted-thiazole-compounds>]

Disclaimer & Data Validity:

The information provided in this document is for Research Use Only (RUO) and is strictly not intended for diagnostic or therapeutic procedures. While BenchChem strives to provide accurate protocols, we make no warranties, express or implied, regarding the fitness of this product for every specific experimental setup.

Technical Support: The protocols provided are for reference purposes. Unsure if this reagent suits your experiment?

Need Industrial/Bulk Grade? [Request Custom Synthesis Quote](#)

BenchChem

Our mission is to be the trusted global source of essential and advanced chemicals, empowering scientists and researchers to drive progress in science and industry.

Contact

Address: 3281 E Guasti Rd

Ontario, CA 91761, United States

Phone: (601) 213-4426

Email: info@benchchem.com

[Contact our Ph.D. Support Team for a compatibility check](#)