

improving peak resolution in sertraline HPLC analysis

Author: BenchChem Technical Support Team. **Date:** May 2026

Compound of Interest

Compound Name: *3-Dechloro Sertraline Hydrochloride*
CAS No.: *79646-00-7*
Cat. No.: *B139581*

[Get Quote](#)

Technical Support Center: Sertraline HPLC Analysis

Welcome to the technical support center for sertraline HPLC analysis. This guide is designed for researchers, scientists, and drug development professionals to troubleshoot and optimize the chromatographic separation of sertraline. Here, we move beyond generic advice to provide in-depth, scientifically-grounded solutions to common challenges encountered in the laboratory. Our approach is rooted in explaining the "why" behind each recommendation, empowering you to make informed decisions for robust and reproducible results.

Frequently Asked Questions (FAQs)

Here are answers to some of the most common questions we receive regarding sertraline HPLC analysis.

Q1: Why is my sertraline peak exhibiting significant tailing?

Peak tailing for sertraline, a basic compound, is most commonly caused by secondary interactions with residual silanol groups on the silica-based stationary phase of the HPLC column.[1][2][3][4] At a typical mobile phase pH (above 3), these silanol groups (Si-OH) can become ionized (SiO⁻), creating active sites that interact strongly with the protonated amine group of sertraline.[1][3] This strong, secondary ionic interaction, in addition to the primary reversed-phase hydrophobic interaction, leads to a portion of the analyte being retained longer, resulting in a tailed peak.[1][5]

Q2: What is a good starting mobile phase for sertraline analysis?

A common and effective starting point for sertraline analysis is a mixture of acetonitrile (ACN) and a buffered aqueous phase.[6] For example, a mobile phase of Acetonitrile and 0.1% Orthophosphoric Acid (OPA) in water (e.g., in a ratio of 80:20 v/v) has been shown to provide good peak shape and separation.[6] The low pH of the OPA helps to suppress the ionization of silanol groups, minimizing peak tailing.[7] Methanol can also be used as the organic modifier, often mixed with water or a buffer.[8][9][10]

Q3: How does the pH of the mobile phase affect the retention and peak shape of sertraline?

The pH of the mobile phase is a critical parameter in the analysis of sertraline due to its basic nature.

- Low pH (around 2.5-4.0): At low pH, the amine group of sertraline is protonated (positively charged), making it more polar and potentially reducing retention time in reversed-phase chromatography. However, a low pH also protonates the residual silanol groups on the column packing, preventing them from becoming negatively charged.[7] This suppression of silanol activity is crucial for achieving symmetrical peaks.[1][7][11]
- Neutral to High pH (above 7.0): At higher pH values, sertraline will be in its free base form, making it more hydrophobic and increasing its retention. However, at these pH levels, silanol groups become deprotonated and negatively charged, leading to strong ionic interactions and significant peak tailing.[3] Therefore, working at a higher pH is generally not recommended unless using a specialized column designed for high pH stability.

It is important to choose a pH that is at least 2 units away from the analyte's pKa to ensure a single ionic form and thus sharper peaks.[12]

Q4: Can I use a C8 column instead of a C18 for sertraline analysis?

Yes, a C8 column can be used for sertraline analysis. C8 columns are less hydrophobic than C18 columns, which will generally result in shorter retention times for sertraline. This can be advantageous for developing faster analytical methods. However, the selectivity (the ability to separate sertraline from its impurities or other compounds) may be different. If you are analyzing sertraline in the presence of related compounds, it is important to validate the separation on the C8 column to ensure adequate resolution.

Troubleshooting Guide: Improving Peak Resolution

Poor resolution between sertraline and its related substances or degradation products is a common challenge. This guide provides a systematic approach to diagnosing and resolving these issues.

Issue: Co-eluting Peaks or Poor Resolution

When two or more peaks are not adequately separated, it compromises the accuracy of quantification. The following steps will guide you through optimizing your method to improve resolution.

The composition of the mobile phase has a significant impact on selectivity and resolution.

1.1. Adjust the Organic Modifier Percentage:

- Principle: In reversed-phase chromatography, decreasing the percentage of the organic modifier (e.g., acetonitrile or methanol) in the mobile phase will increase the retention time of the analytes. This increased interaction with the stationary phase often leads to better separation.
- Protocol:
 - Start with your current mobile phase composition.
 - Systematically decrease the organic modifier content in small increments (e.g., 2-5%). For example, if you are using 80:20 ACN:Buffer, try 78:22, 75:25, and so on.
 - After each change, allow the column to equilibrate fully before injecting your sample.

- Monitor the resolution between the critical peak pair.

1.2. Change the Organic Modifier:

- Principle: Acetonitrile and methanol have different solvent properties and can offer different selectivities. If adjusting the percentage of one doesn't yield the desired resolution, switching to the other (or using a ternary mixture) can alter the elution order and improve separation.
- Protocol:
 - If you are using acetonitrile, try replacing it with methanol at a concentration that gives a similar retention time for the main peak.
 - Alternatively, explore ternary mixtures (e.g., Acetonitrile/Methanol/Buffer) to fine-tune the selectivity.[\[10\]](#)

1.3. Adjust the pH of the Aqueous Phase:

- Principle: As discussed in the FAQs, pH can significantly alter the retention and selectivity of ionizable compounds like sertraline and its impurities. A small change in pH can sometimes dramatically improve resolution.
- Protocol:
 - Prepare mobile phases with slightly different pH values (e.g., in 0.2-0.5 unit increments) around your current pH.
 - Ensure you are using a suitable buffer for the desired pH range. Phosphate buffers are common and effective.[\[10\]](#)
 - Always check the pH stability range of your column to prevent damage.[\[12\]](#)

Table 1: Example Mobile Phase Compositions for Sertraline HPLC Analysis

Organic Modifier	Aqueous Phase	Ratio (v/v)	Column Type	Reference
Acetonitrile	0.1% Orthophosphoric Acid in Water	80:20	C18	[6]
Methanol	Water	75:25	C18	[8][9]
Methanol, Acetonitrile	Monobasic Potassium Phosphate Buffer (pH 4.0)	25:25:50	C18	[10]
Acetonitrile	Phosphate Buffer (pH 2.9)	80:20	C18	
Acetonitrile, Methanol	Buffer (pH 7.5 with triethylamine)	35:20:45	C18	[13]

If mobile phase optimization is insufficient, consider the stationary phase and operating temperature.

2.1. Evaluate Column Chemistry:

- Principle: Not all C18 columns are the same. Differences in silica purity, end-capping, and bonding density can lead to different selectivities. Using a column with a different chemistry can resolve co-eluting peaks. For separating sertraline's enantiomers, a chiral stationary phase is necessary.[14]
- Protocol:
 - If available, try a C18 column from a different manufacturer.
 - Consider a column with a different stationary phase, such as a phenyl-hexyl or a polar-embedded phase, which can offer alternative selectivities for aromatic compounds like sertraline.

- For enantiomeric separation, a chiral column such as one based on amylose tris(3-chloro-5-methylphenylcarbamate) or cyclodextrin can be effective.[\[14\]](#)[\[15\]](#)

2.2. Adjust Column Temperature:

- Principle: Temperature affects the viscosity of the mobile phase and the kinetics of mass transfer, which can influence retention times and selectivity.
- Protocol:
 - If your HPLC system has a column oven, try varying the temperature in 5°C increments (e.g., from 25°C to 40°C).
 - Increasing the temperature generally decreases retention times and can sometimes improve peak shape and resolution.[\[14\]](#)

As previously mentioned, silanol interactions are a primary cause of poor peak shape for sertraline. Here is a focused approach to address this.

3.1. Use of Mobile Phase Additives:

- Principle: Small amounts of basic additives can compete with the analyte for active silanol sites, effectively masking them and improving peak shape.
- Protocol:
 - Add a small concentration of a basic modifier like Diethylamine (DEA) or Triethylamine (TEA) to the mobile phase (e.g., 0.1%).[\[13\]](#)[\[14\]](#) These additives can significantly improve the symmetry of basic compounds.[\[14\]](#)
 - Note that these additives can sometimes suppress ionization in mass spectrometry detection.

Diagram 1: Troubleshooting Workflow for Poor Peak Resolution

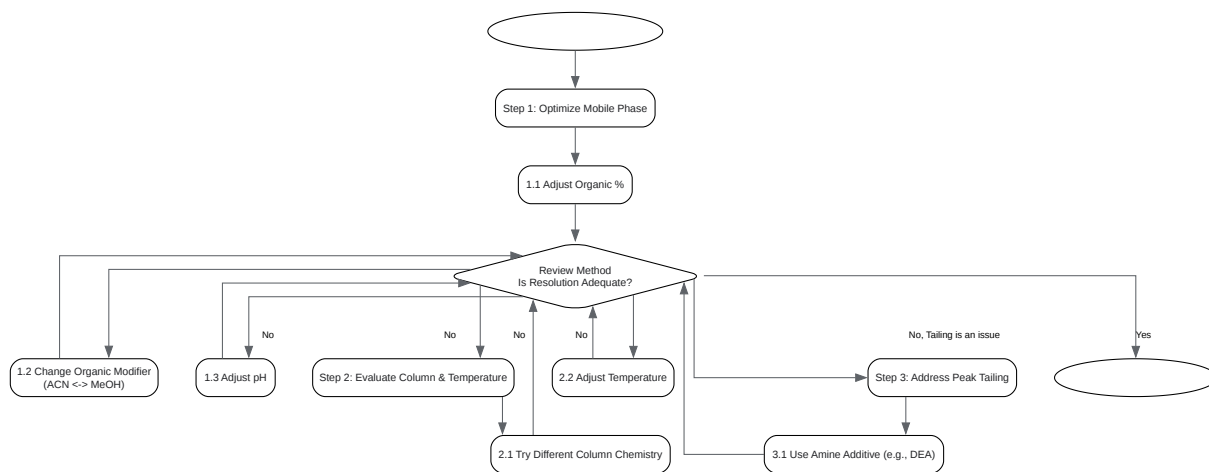

[Click to download full resolution via product page](#)

Caption: A systematic workflow for troubleshooting poor peak resolution in sertraline HPLC analysis.

Issue: Split Peaks

Split peaks can be perplexing and can arise from several instrumental or chemical issues.

Possible Cause 1: Mismatch between Sample Solvent and Mobile Phase

- Explanation: If the sample is dissolved in a solvent that is much stronger (more organic) than the mobile phase, it can cause the analyte to travel through the top of the column in a distorted band, leading to a split peak.
- Solution: Whenever possible, dissolve and inject your sample in the mobile phase itself. If this is not feasible due to solubility issues, use a solvent that is as weak as or weaker than the mobile phase.

Possible Cause 2: Co-elution of Two Different Compounds

- Explanation: What appears to be a split peak might actually be two different compounds eluting very close to each other.[\[16\]](#) This could be an impurity or a degradation product.
- Solution: Follow the steps in the "Improving Peak Resolution" section above to try and separate the two components. A slight modification of the mobile phase is often sufficient to resolve them into two distinct peaks.

Possible Cause 3: Column Void or Contamination

- Explanation: A void or channel at the head of the column can cause the sample band to split as it enters the stationary phase.[\[16\]](#) Contamination on the column frit can also lead to a disturbed flow path.[\[16\]](#)[\[17\]](#)
- Solution:
 - First, try flushing the column with a strong solvent to remove any potential contaminants.[\[17\]](#)
 - If the problem persists, try reversing the column (only if the manufacturer's instructions permit) and flushing it at a low flow rate.
 - If a void is suspected, the column will likely need to be replaced.[\[16\]](#) Using a guard column can help extend the life of your analytical column.[\[18\]](#)

Diagram 2: Sertraline Interaction with C18 Stationary Phase at Different pH

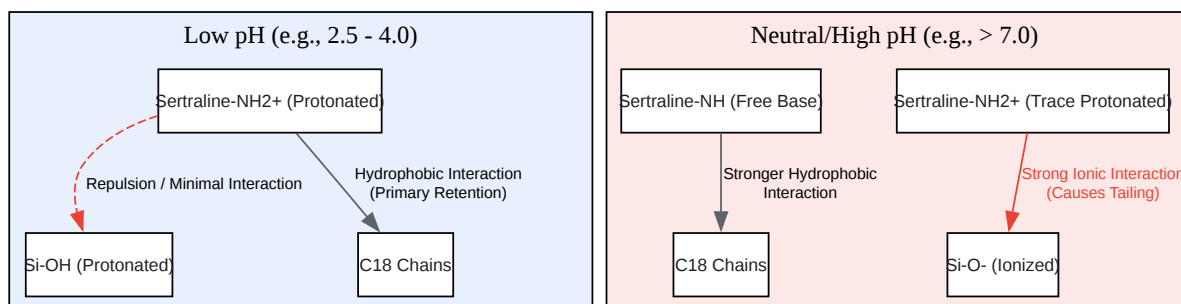

[Click to download full resolution via product page](#)

Caption: The effect of mobile phase pH on the interaction of sertraline with a C18 stationary phase.

References

- Jain, D. K., et al. (n.d.). Estimation of sertraline by chromatographic (HPLC-UV273 nm) technique under hydrolytic stress conditions. PubMed Central. Retrieved from [[Link](#)]
- Patel, R. B., et al. (2022). Development and Validation of RP-UHPLC Method for Determination of Sertraline in Bulk Drug and Dosage Form. Sciforum. Retrieved from [[Link](#)]
- D'Orazio, G., et al. (2020). Single-run reversed-phase HPLC method for determining sertraline content, enantiomeric purity, and related substances in drug substance and finished product. National Institutes of Health. Retrieved from [[Link](#)]
- Jain, D. K., et al. (2011). Estimation of sertraline by chromatographic (HPLC-UV273 nm) technique under hydrolytic stress conditions. ResearchGate. Retrieved from [[Link](#)]
- Pandya, V. M., et al. (2023). A Simple HPLC Method for the Estimation of Sertraline Hydrochloride in Unit Dose Formulations. International Journal of Pharmaceutical Sciences and Research. Retrieved from [[Link](#)]
- Bairagi, S. H., et al. (2020). A new stability indicating RP-HPLC method for the determination of Sertraline in bulk and pharmaceutical dosage form. World Journal of Pharmaceutical

Research. Retrieved from [\[Link\]](#)

- Chen, S., et al. (2006). HPLC determination of sertraline in bulk drug, tablets and capsules using hydroxypropyl- β -cyclodextrin as mobile phase additive. ResearchGate. Retrieved from [\[Link\]](#)
- Reddy, B., et al. (2010). A validated LC method for the determination of assay and purity of DRF-2725 and its enantiomers by chiral chromatography. Rasayan Journal of Chemistry. Retrieved from [\[Link\]](#)
- Nováková, L., et al. (2011). Performance of amines as silanol suppressors in reversed-phase liquid chromatography. ResearchGate. Retrieved from [\[Link\]](#)
- Devala, R. G., et al. (2007). RP-HPLC Method For The Determination Of Sertraline Hydrochloride In Bulk And In Pharmaceutical Dosage Forms. Trade Science Inc. Retrieved from [\[Link\]](#)
- MicroSolv Technology Corporation. (n.d.). Sertraline Tablet Analyzed with HPLC. Retrieved from [\[Link\]](#)
- SCION Instruments. (n.d.). HPLC Troubleshooting Guide. Retrieved from [\[Link\]](#)
- Cichocki, A. (2024). Peak Splitting in HPLC: Causes and Solutions. Separation Science. Retrieved from [\[Link\]](#)
- United States Pharmacopeia. (2011). Sertraline Hydrochloride Tablets. USP-NF. Retrieved from [\[Link\]](#)
- Kumar, A., et al. (2016). Synthesis, Characterization, Identification and Quantification of Sertraline Hydrochloride Related Impurities. Hilaris Publisher. Retrieved from [\[Link\]](#)
- Eap, C. B., et al. (2004). LC–MS Analysis of Sertraline and Its Active Metabolite in Human Serum Using a Silica Column with a NonAqueous Polar Mobile Phase. ResearchGate. Retrieved from [\[Link\]](#)
- Moravek. (n.d.). Exploring the Role of pH in HPLC Separation. Retrieved from [\[Link\]](#)
- Agilent Technologies. (n.d.). HPLC Troubleshooting Guide. Retrieved from [\[Link\]](#)

- Element Lab Solutions. (n.d.). Peak Tailing in HPLC. Retrieved from [[Link](#)]
- Phenomenex. (n.d.). HPLC Troubleshooting Mini Guide - Peak Issues. Retrieved from [[Link](#)]
- Chrom Tech. (n.d.). What Causes Peak Tailing in HPLC?. Retrieved from [[Link](#)]
- Pharma Growth Hub. (2023). What is the effect of free silanols in RPLC and how to reduce it?. Retrieved from [[Link](#)]
- Labcompare. (2021). LABTips: How to Prevent Tailing Peaks in HPLC. Retrieved from [[Link](#)]
- Phenomenex. (n.d.). How to Reduce Peak Tailing in HPLC?. Retrieved from [[Link](#)]
- MAC-MOD Analytical. (2023). The Two Reasons Why HPLC Peaks Tail and How to Reduce Peak Tailing. YouTube. Retrieved from [[Link](#)]

Need Custom Synthesis?

BenchChem offers custom synthesis for rare earth carbides and specific isotopic labeling.

Email: info@benchchem.com or [Request Quote Online](#).

Sources

- [1. elementlabsolutions.com](https://www.elementlabsolutions.com) [[elementlabsolutions.com](https://www.elementlabsolutions.com)]
- [2. chromtech.com](https://www.chromtech.com) [[chromtech.com](https://www.chromtech.com)]
- [3. pharmagrowthhub.com](https://www.pharmagrowthhub.com) [[pharmagrowthhub.com](https://www.pharmagrowthhub.com)]
- [4. Understanding Peak Tailing in HPLC | Phenomenex](https://www.phenomenex.com) [[phenomenex.com](https://www.phenomenex.com)]
- [5. youtube.com](https://www.youtube.com) [[youtube.com](https://www.youtube.com)]
- [6. sciforum.net](https://www.sciforum.net) [[sciforum.net](https://www.sciforum.net)]
- [7. labcompare.com](https://www.labcompare.com) [[labcompare.com](https://www.labcompare.com)]
- [8. Estimation of sertraline by chromatographic \(HPLC-UV273 nm\) technique under hydrolytic stress conditions - PMC](https://pubmed.ncbi.nlm.nih.gov) [[pmc.ncbi.nlm.nih.gov](https://pubmed.ncbi.nlm.nih.gov)]
- [9. researchgate.net](https://www.researchgate.net) [[researchgate.net](https://www.researchgate.net)]
- [10. ijpsr.com](https://www.ijpsr.com) [[ijpsr.com](https://www.ijpsr.com)]

- [11. researchgate.net \[researchgate.net\]](#)
- [12. moravek.com \[moravek.com\]](#)
- [13. tsijournals.com \[tsijournals.com\]](#)
- [14. Single-run reversed-phase HPLC method for determining sertraline content, enantiomeric purity, and related substances in drug substance and finished product - PMC \[pmc.ncbi.nlm.nih.gov\]](#)
- [15. researchgate.net \[researchgate.net\]](#)
- [16. Peak Splitting in HPLC: Causes and Solutions | Separation Science \[sepscience.com\]](#)
- [17. HPLC Troubleshooting Guide \[scioninstruments.com\]](#)
- [18. ccc.chem.pitt.edu \[ccc.chem.pitt.edu\]](#)
- [To cite this document: BenchChem. \[improving peak resolution in sertraline HPLC analysis\]. BenchChem, \[2026\]. \[Online PDF\]. Available at: \[https://www.benchchem.com/product/b139581/docs#improving-peak-resolution-in-sertraline-hplc-analysis\]](#)

Disclaimer & Data Validity:

The information provided in this document is for Research Use Only (RUO) and is strictly not intended for diagnostic or therapeutic procedures. While BenchChem strives to provide accurate protocols, we make no warranties, express or implied, regarding the fitness of this product for every specific experimental setup.

Technical Support: The protocols provided are for reference purposes. Unsure if this reagent suits your experiment?

Need Industrial/Bulk Grade? [Request Custom Synthesis Quote](#)

BenchChem

Our mission is to be the trusted global source of essential and advanced chemicals, empowering scientists and researchers to drive progress in science and industry.

Contact

Address: 3281 E Guasti Rd
Ontario, CA 91761, United States
Phone: (601) 213-4426
Email: info@benchchem.com

Contact our Ph.D. Support Team for a compatibility check