

In Vitro Experimental Protocols for (E)-10-Hydroxynortriptyline: A Comprehensive Guide

Author: BenchChem Technical Support Team. **Date:** April 2026

Compound of Interest

Compound Name: (E)-10-Hydroxynortriptyline
maleate

CAS No.: 74853-74-0

Cat. No.: B139804

[Get Quote](#)

For Researchers, Scientists, and Drug Development Professionals

These application notes provide detailed experimental protocols for the in vitro characterization of (E)-10-Hydroxynortriptyline, an active metabolite of the tricyclic antidepressant nortriptyline. The following sections outline methodologies for assessing its pharmacological activity, metabolic stability, and potential toxicity, accompanied by quantitative data and visual workflows to guide researchers in their investigations.

Pharmacological Profile of (E)-10-Hydroxynortriptyline

(E)-10-Hydroxynortriptyline is recognized primarily as an inhibitor of the norepinephrine transporter, playing a significant role in the overall therapeutic effect of its parent drug, nortriptyline.^{[1][2]} In vitro studies have established its activity profile, which is summarized in the tables below.

Table 1: Receptor and Transporter Binding Affinity

Target	(E)-10-Hydroxynortriptyline	Nortriptyline (for comparison)	Reference
Muscarinic Acetylcholine Receptors	~10-18 times lower affinity than Nortriptyline	Ki: ~20 nM (hM1)	[3][4]
Norepinephrine Transporter (NET)	Not explicitly quantified, but noted to be a potent inhibitor	-	[5]
Serotonin Transporter (SERT)	IC50: 6700 nM	IC50: 940 nM	[6]

Table 2: In Vitro Metabolism

Enzyme	Substrate	Metabolite	Km (μM)	Reference
Human CYP2D6	Nortriptyline	(E)-10-Hydroxynortriptyline	2.1	[7]
Human CYP3A4	Nortriptyline	(E)-10-Hydroxynortriptyline	37.4	[7]
Human Liver Microsomes (High-affinity component)	Nortriptyline	(E)-10-Hydroxynortriptyline	1.3 ± 0.4	[7]
Human Liver Microsomes (Low-affinity component)	Nortriptyline	(E)-10-Hydroxynortriptyline	24.4 ± 7	[7]

Experimental Protocols

Detailed methodologies for key in vitro experiments are provided below. These protocols are intended as a guide and may require optimization based on specific laboratory conditions and equipment.

Protocol 1: Norepinephrine Transporter (NET) Uptake Assay

This protocol is designed to determine the inhibitory potency (IC₅₀) of (E)-10-Hydroxynortriptyline on the norepinephrine transporter.

1. Cell Culture:

- Utilize a cell line stably expressing the human norepinephrine transporter (hNET), such as HEK293-hNET cells.
- Culture cells in appropriate media and conditions as recommended by the supplier.

2. Assay Procedure:

- Seed cells in a 96-well plate and allow them to adhere overnight.
- Prepare a range of concentrations of (E)-10-Hydroxynortriptyline and a positive control (e.g., Desipramine).
- Pre-incubate the cells with the test compounds for 15-30 minutes at 37°C.
- Initiate the uptake reaction by adding a solution containing a labeled norepinephrine substrate (e.g., [3H]-Norepinephrine).
- Incubate for a predetermined time (e.g., 10-20 minutes) at 37°C to allow for substrate uptake.
- Terminate the uptake by rapidly washing the cells with ice-cold buffer.
- Lyse the cells and measure the amount of incorporated radiolabel using a scintillation counter.

3. Data Analysis:

- Calculate the percentage of inhibition for each concentration of (E)-10-Hydroxynortriptyline relative to the control.
- Determine the IC50 value by fitting the data to a sigmoidal dose-response curve using appropriate software.

Protocol 2: Muscarinic Acetylcholine Receptor Binding Assay

This protocol measures the binding affinity (K_i) of (E)-10-Hydroxynortriptyline to muscarinic acetylcholine receptors.

1. Membrane Preparation:

- Use cell membranes from a cell line expressing the desired muscarinic receptor subtype (e.g., CHO-M1) or from a relevant tissue source (e.g., rat brain cortex).
- Homogenize the cells or tissue in a suitable buffer and prepare a crude membrane fraction by centrifugation.

2. Binding Assay:

- In a 96-well plate, combine the prepared membranes, a radiolabeled muscarinic antagonist (e.g., [3H]-QNB), and varying concentrations of (E)-10-Hydroxynortriptyline or a known competitor (e.g., Atropine).
- Incubate the mixture to allow binding to reach equilibrium.
- Separate the bound from free radioligand by rapid filtration through a glass fiber filter plate.
- Wash the filters to remove unbound radioligand.
- Measure the radioactivity retained on the filters using a scintillation counter.

3. Data Analysis:

- Determine the IC50 value from the competition binding curve.

- Calculate the K_i value using the Cheng-Prusoff equation, which takes into account the concentration and K_d of the radioligand.

Protocol 3: In Vitro Cytotoxicity Assay (LDH Release)

This protocol assesses the potential cytotoxicity of (E)-10-Hydroxynortriptyline by measuring the release of lactate dehydrogenase (LDH) from damaged cells.

1. Cell Culture:

- Use a relevant cell line, such as the human hepatoma cell line HepG2, to assess potential hepatotoxicity.
- Seed cells in a 96-well plate and allow them to grow to a confluent monolayer.

2. Treatment:

- Prepare a range of concentrations of (E)-10-Hydroxynortriptyline.
- Expose the cells to the test compound for a specified duration (e.g., 24, 48, or 72 hours).
- Include a positive control for cytotoxicity (e.g., Triton X-100) and a vehicle control.

3. LDH Measurement:

- After the incubation period, collect the cell culture supernatant.
- Use a commercially available LDH cytotoxicity assay kit to measure the amount of LDH released into the supernatant.
- Follow the manufacturer's instructions for the assay, which typically involves an enzymatic reaction that produces a colored product.
- Measure the absorbance at the appropriate wavelength using a plate reader.

4. Data Analysis:

- Calculate the percentage of cytotoxicity for each concentration relative to the positive control.

- Determine the concentration of (E)-10-Hydroxynortriptyline that causes 50% cytotoxicity (IC50).

Protocol 4: hERG Potassium Channel Blockade Assay

This protocol evaluates the potential for (E)-10-Hydroxynortriptyline to block the hERG potassium channel, a key indicator of proarrhythmic risk.

1. Cell Culture:

- Utilize a cell line stably expressing the hERG channel, such as HEK293-hERG cells.

2. Electrophysiology (Patch-Clamp):

- Perform whole-cell patch-clamp recordings on individual cells.
- Apply a specific voltage-clamp protocol to elicit hERG channel currents.
- Perfuse the cells with varying concentrations of (E)-10-Hydroxynortriptyline.
- Record the hERG current before and after application of the compound.

3. Data Analysis:

- Measure the reduction in the hERG tail current amplitude at each concentration.
- Calculate the percentage of channel block.
- Determine the IC50 value by fitting the concentration-response data to a suitable equation. Nortriptyline has been shown to block the hERG channel with an IC50 of 2.20 μ M, and it is important to assess if its metabolite shares this property.[\[8\]](#)[\[9\]](#)

Visualizing In Vitro Workflows and Pathways

To aid in the understanding of the experimental processes and the biological context, the following diagrams have been generated using the DOT language.

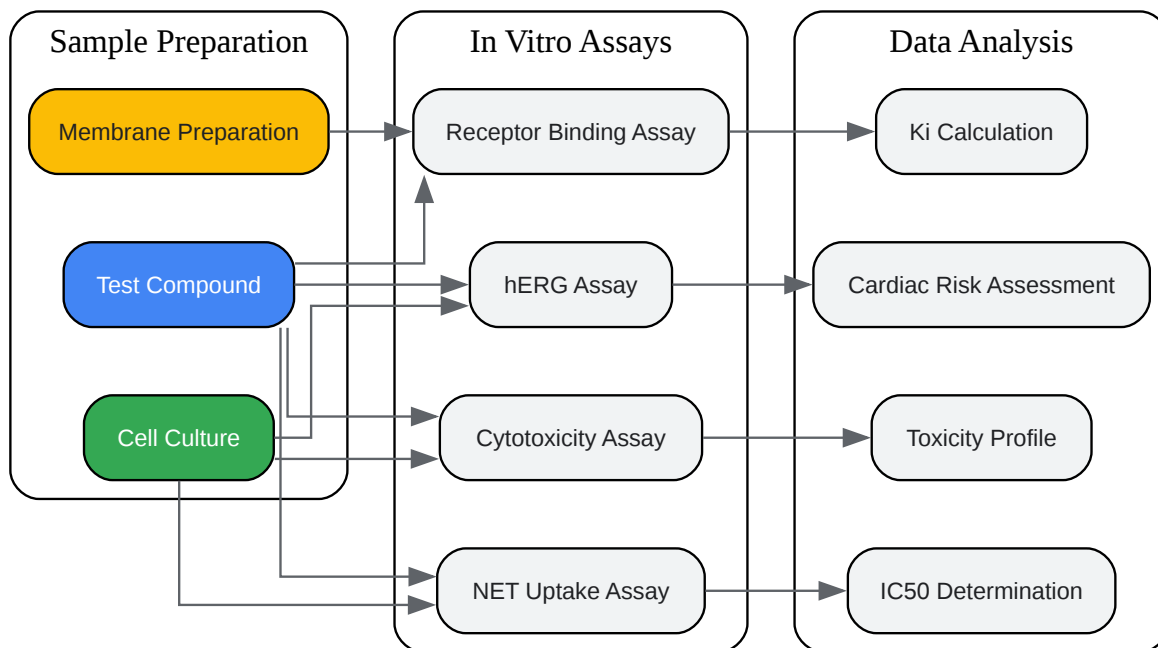

[Click to download full resolution via product page](#)

General workflow for in vitro characterization.

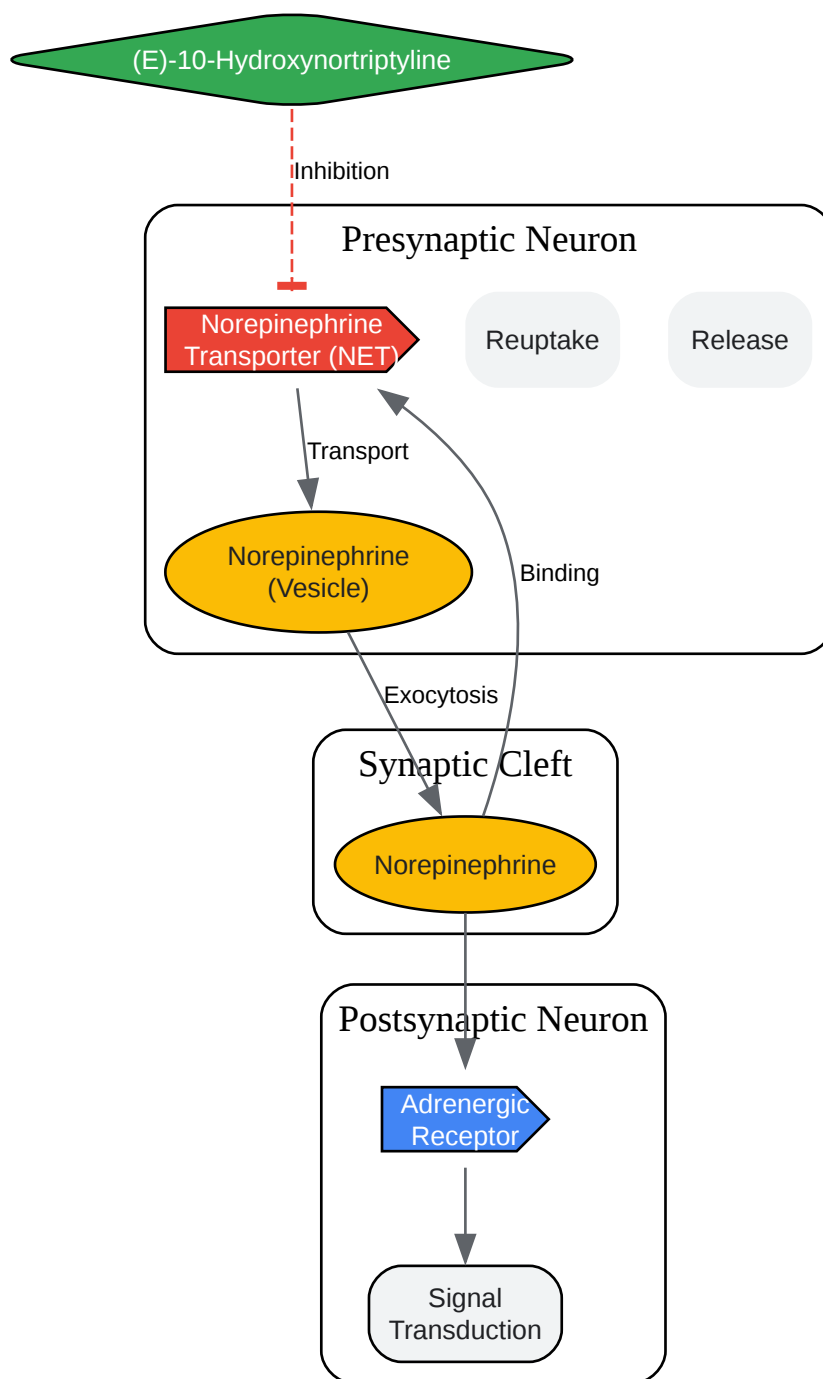

[Click to download full resolution via product page](#)

Norepinephrine reuptake inhibition by (E)-10-Hydroxynortriptyline.

Conclusion

The provided protocols and data offer a foundational framework for the in vitro investigation of (E)-10-Hydroxynortriptyline. While it demonstrates clear activity as a norepinephrine reuptake

inhibitor with reduced anticholinergic side effects compared to its parent compound, further quantitative analysis is necessary to fully delineate its pharmacological and toxicological profile. In vivo studies have suggested that (E)-10-hydroxynortriptyline is less cardiotoxic than nortriptyline, as it caused significantly fewer arrhythmias in swine.[10] However, a thorough in vitro assessment of its effects on cardiac ion channels, particularly hERG, is crucial for a comprehensive safety evaluation. Researchers are encouraged to adapt and expand upon these methodologies to generate a more complete understanding of this significant metabolite.

Need Custom Synthesis?

BenchChem offers custom synthesis for rare earth carbides and specific isotopic labeling.

Email: info@benchchem.com or [Request Quote Online](#).

References

- 1. Active hydroxymetabolites of antidepressants. Emphasis on E-10-hydroxy-nortriptyline - PubMed [pubmed.ncbi.nlm.nih.gov]
- 2. Clinical and biochemical effects during treatment of depression with nortriptyline: the role of 10-hydroxynortriptyline - PubMed [pubmed.ncbi.nlm.nih.gov]
- 3. Affinity of nortriptyline and its E-10-hydroxy metabolite for muscarinic receptors - PubMed [pubmed.ncbi.nlm.nih.gov]
- 4. Weak binding of 10-hydroxymetabolites of nortriptyline to rat brain muscarinic acetylcholine receptors - PubMed [pubmed.ncbi.nlm.nih.gov]
- 5. Pronounced inhibition of noradrenaline uptake by 10-hydroxymetabolites of nortriptyline - PubMed [pubmed.ncbi.nlm.nih.gov]
- 6. Serotonin uptake inhibition during treatment of depression with nortriptyline caused by parent drug and not by 10-hydroxymetabolites - PubMed [pubmed.ncbi.nlm.nih.gov]
- 7. Nortriptyline E-10-hydroxylation in vitro is mediated by human CYP2D6 (high affinity) and CYP3A4 (low affinity): implications for interactions with enzyme-inducing drugs - PubMed [pubmed.ncbi.nlm.nih.gov]
- 8. researchgate.net [researchgate.net]
- 9. Effects of nortriptyline on QT prolongation: a safety pharmacology study - PubMed [pubmed.ncbi.nlm.nih.gov]

- [10. Comparative cardiotoxicity of nortriptyline and its isomeric 10-hydroxymetabolites - PubMed \[pubmed.ncbi.nlm.nih.gov\]](#)
- To cite this document: BenchChem. [In Vitro Experimental Protocols for (E)-10-Hydroxynortriptyline: A Comprehensive Guide]. BenchChem, [2026]. [Online PDF]. Available at: [<https://www.benchchem.com/product/b139804/docs#in-vitro-experimental-protocols-for-e-10-hydroxynortriptyline-a-comprehensive-guide>]

Disclaimer & Data Validity:

The information provided in this document is for Research Use Only (RUO) and is strictly not intended for diagnostic or therapeutic procedures. While BenchChem strives to provide accurate protocols, we make no warranties, express or implied, regarding the fitness of this product for every specific experimental setup.

Technical Support: The protocols provided are for reference purposes. Unsure if this reagent suits your experiment?

Need Industrial/Bulk Grade? [Request Custom Synthesis Quote](#)

BenchChem

Our mission is to be the trusted global source of essential and advanced chemicals, empowering scientists and researchers to drive progress in science and industry.

Contact

Address: 3281 E Guasti Rd
Ontario, CA 91761, United States
Phone: (601) 213-4426
Email: info@benchchem.com

[Contact our Ph.D. Support Team for a compatibility check](#)