

# Application Notes and Protocols for Enzymatic Assay of Pantoic Acid

**Author:** BenchChem Technical Support Team. **Date:** April 2026

## Compound of Interest

Compound Name: *2,4-Dihydroxy-3,3-dimethyl-butanoic acid*

CAS No.: *1902-01-8*

Cat. No.: *B139305*

[Get Quote](#)

## For Researchers, Scientists, and Drug Development Professionals

These application notes provide a detailed protocol for an enzymatic assay utilizing pantoic acid as a substrate, primarily focusing on the activity of Pantoate- $\beta$ -alanine ligase (PBL), also known as Pantothenate Synthetase (PS). This enzyme is crucial in the biosynthesis of pantothenic acid (Vitamin B5) and serves as a target for antimicrobial drug development.

## Introduction

Pantoic acid is a key intermediate in the biosynthesis of Coenzyme A (CoA), an essential cofactor in numerous metabolic pathways. The enzymatic conversion of pantoic acid is a critical step in this pathway, making the enzymes involved attractive targets for research and drug discovery. One such key enzyme is Pantoate- $\beta$ -alanine ligase (EC 6.3.2.1), which catalyzes the ATP-dependent condensation of (R)-pantoic acid and  $\beta$ -alanine to produce (R)-pantothenic acid.[1][2][3] This document provides a detailed protocol for assaying the activity of PBL.

## Principle of the Assay

The activity of Pantoate- $\beta$ -alanine ligase is determined by measuring the rate of product formation, pantothenic acid, or the consumption of one of the substrates (ATP, pantoic acid, or  $\beta$ -alanine). A common method involves quantifying the amount of pantothenic acid produced. The reaction catalyzed by PBL is as follows:



This protocol is adapted from a published method and can be modified for specific experimental needs.[5]

## Materials and Reagents

Reagent	Stock Concentration	Final Concentration
Tris Buffer	1 M, pH 8.0	0.1 M
D-(-)-Pantoic acid	1 M	0.1 M
$\beta$ -Alanine	1 M	0.1 M
ATP	100 mM	10 mM
MgCl <sub>2</sub>	100 mM	10 mM
KCl	100 mM	10 mM
Pantoate- $\beta$ -alanine ligase (PBL)	Varies	As required
1 M NaOH	1 M	For stopping reaction

## Experimental Protocol

This protocol outlines the steps for a standard PBL enzyme assay in a total reaction volume of 1 mL.[5]

### 4.1. Preparation of Reagents

- Prepare all stock solutions in high-purity water and adjust the pH of the Tris buffer to 8.0.

- Store stock solutions at -20°C. Pantoic acid and β-alanine solutions should be freshly prepared or stored for a limited time.

#### 4.2. Assay Procedure

- In a microcentrifuge tube, prepare the assay mixture by adding the following components in the specified order:
  - 750 μL of 0.1 M Tris buffer (pH 8.0)
  - 100 μL of 1 M D-(-)-pantoic acid
  - 100 μL of 1 M β-alanine
  - 100 μL of 100 mM ATP
  - 100 μL of 100 mM MgCl<sub>2</sub>
  - 100 μL of 100 mM KCl
  - Make up the volume to 990 μL with purified water.
- Pre-incubate the assay mixture at 37°C for 5 minutes to reach thermal equilibrium.
- Initiate the reaction by adding 10 μL of the crude or purified enzyme solution to the assay mixture.
- Incubate the reaction at 37°C for 20 minutes.
- Stop the reaction by adding 200 μL of 1 M NaOH.
- Prepare a blank control by adding the enzyme after the addition of NaOH.

#### 4.3. Detection of Product

The product, pantothenic acid, can be quantified using various methods, including:

- High-Performance Liquid Chromatography (HPLC): This is a common and accurate method for separating and quantifying pantothenic acid.[6]

- Microbiological Assay: This method utilizes microorganisms, such as *Lactobacillus plantarum*, that require pantothenic acid for growth. The growth of the microorganism is proportional to the amount of pantothenic acid present.[7]
- Enzyme-Linked Immunosorbent Assay (ELISA): Specific antibodies against pantothenic acid can be used for its quantification.[8]

## Data Presentation

The results of the enzymatic assay should be presented clearly. The enzyme activity is typically expressed in Units (U), where one unit is defined as the amount of enzyme that catalyzes the formation of 1  $\mu\text{mol}$  of product per minute under the specified conditions.

Table 1: Summary of Quantitative Data for PBL Assay

Parameter	Value	Reference
pH	8.0	[5]
Temperature	37°C	[5]
Incubation Time	20 min	[5]
Final Volume	1 mL	[5]
Enzyme Source	e.g., <i>E. coli</i> , <i>B. subtilis</i>	[5]

## Visualizations

Diagram 1: Signaling Pathway of Pantothenic Acid Biosynthesis

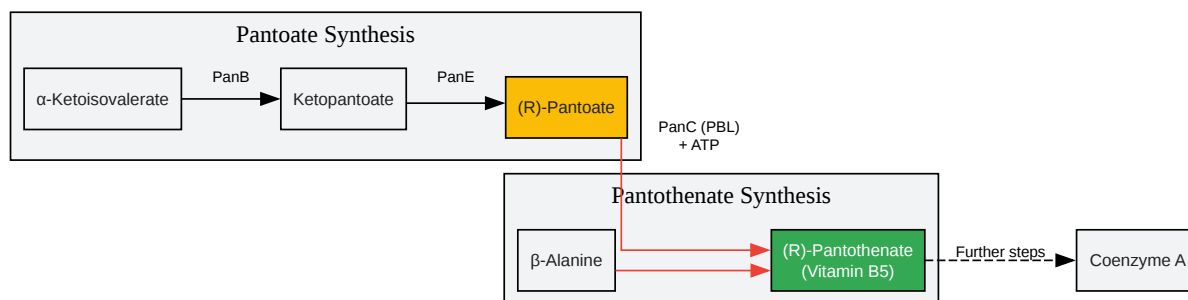

[Click to download full resolution via product page](#)

Caption: Biosynthetic pathway of pantothenic acid from  $\alpha$ -ketoisovalerate and  $\beta$ -alanine.

Diagram 2: Experimental Workflow for Pantoate- $\beta$ -alanine Ligase Assay

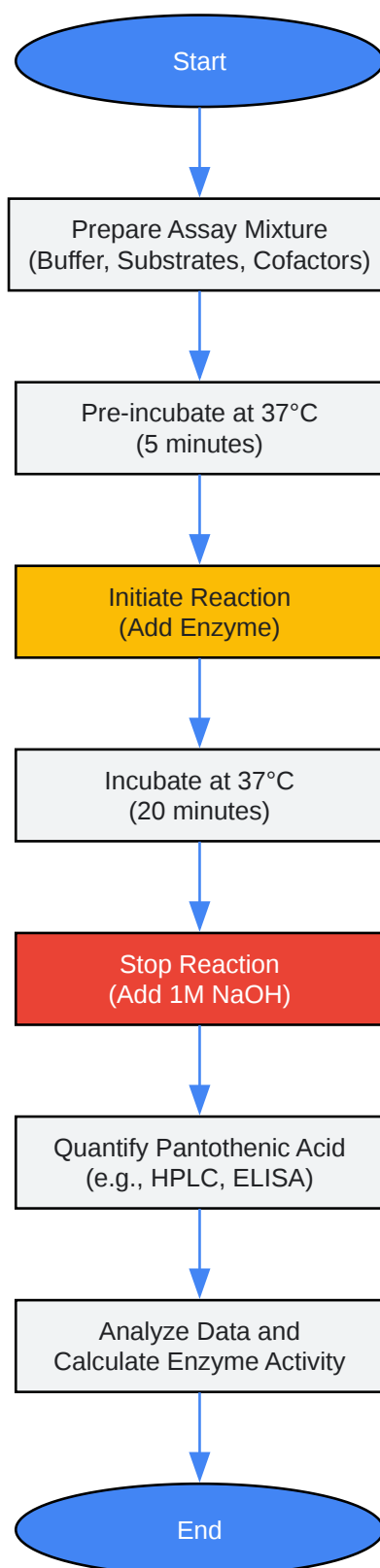

[Click to download full resolution via product page](#)

Caption: Step-by-step workflow for the Pantoate- $\beta$ -alanine ligase enzymatic assay.

### Need Custom Synthesis?

BenchChem offers custom synthesis for rare earth carbides and specific isotopic labeling.

Email: [info@benchchem.com](mailto:info@benchchem.com) or [Request Quote Online](#).

## References

- 1. The broad amine scope of pantothenate synthetase enables the synthesis of pharmaceutically relevant amides - Organic & Biomolecular Chemistry (RSC Publishing) DOI:10.1039/D1OB00238D [pubs.rsc.org]
- 2. Frontiers | Vitamin in the Crosshairs: Targeting Pantothenate and Coenzyme A Biosynthesis for New Antituberculosis Agents [frontiersin.org]
- 3. Pantoate—beta-alanine ligase - Wikipedia [en.wikipedia.org]
- 4. Pantoate--beta-alanine ligase (AMP-forming) (EC 6.3.2.1) | Protein Target - PubChem [pubchem.ncbi.nlm.nih.gov]
- 5. High-level expression and optimization of pantoate-β-alanine ligase in Bacillus megaterium for the enhanced biocatalytic production of D-pantothenic acid - PMC [pmc.ncbi.nlm.nih.gov]
- 6. Determination of Vitamin B5 in dairy products [sigmaaldrich.com]
- 7. bioagilytix.com [bioagilytix.com]
- 8. Immunoassays for the rapid detection of pantothenic acid in pharmaceutical and food products - PubMed [pubmed.ncbi.nlm.nih.gov]
- To cite this document: BenchChem. [Application Notes and Protocols for Enzymatic Assay of Pantoic Acid]. BenchChem, [2026]. [Online PDF]. Available at: [https://www.benchchem.com/product/b139305/docs#application-notes-and-protocols-for-enzymatic-assay-of-pantoic-acid]

---

### Disclaimer & Data Validity:

The information provided in this document is for Research Use Only (RUO) and is strictly not intended for diagnostic or therapeutic procedures. While BenchChem strives to provide accurate protocols, we make no warranties, express or implied, regarding the fitness of this product for every specific experimental setup.

**Technical Support:** The protocols provided are for reference purposes. Unsure if this reagent suits your experiment?

**Need Industrial/Bulk Grade?** [Request Custom Synthesis Quote](#)

## BenchChem

Our mission is to be the trusted global source of essential and advanced chemicals, empowering scientists and researchers to drive progress in science and industry.

### Contact

Address: 3281 E Guasti Rd  
Ontario, CA 91761, United States  
Phone: (601) 213-4426  
Email: [info@benchchem.com](mailto:info@benchchem.com)

[Contact our Ph.D. Support Team for a compatibility check](#)