

# Application Note: 3-Picolyl Isothiocyanate Hydrobromide in Cell-Based Assays

**Author:** BenchChem Technical Support Team. **Date:** April 2026

## Compound of Interest

Compound Name:	3-Picolyl isothiocyanate hydrobromide
CAS No.:	147342-57-2
Cat. No.:	B139770

[Get Quote](#)

## Introduction & Mechanism of Action

**3-Picolyl isothiocyanate hydrobromide** (3-PITC HBr) is a pyridine-based isothiocyanate (ITC) derivative. Structurally, it is a bioisostere of the well-characterized Benzyl Isothiocyanate (BITC), featuring a pyridine ring in place of the benzene ring.<sup>[1]</sup> This substitution alters the electronic properties and solubility profile while retaining the highly reactive isothiocyanate (-N=C=S) pharmacophore.

## Core Mechanisms[3]

- **Irreversible MIF Inhibition:** The primary application of aryl-alkyl isothiocyanates is the inhibition of Macrophage Migration Inhibitory Factor (MIF). The electrophilic ITC group forms a covalent thiourea bond with the N-terminal Proline-1 residue of MIF, abolishing its tautomerase and cytokine activity.
- **ROS Induction & Apoptosis:** Like other ITCs, 3-PITC depletes cellular glutathione (GSH) pools and modifies cysteine residues on Keap1, activating the Nrf2 antioxidant response.<sup>[1]</sup>

At higher concentrations, this leads to unresolvable Reactive Oxygen Species (ROS) accumulation and apoptosis.[1]

- H<sub>2</sub>S Donation (Secondary): Emerging evidence suggests pyridine-based ITCs can act as slow-releasing hydrogen sulfide (H<sub>2</sub>S) donors, contributing to vasorelaxation and anti-inflammatory effects, distinct from simple MIF inhibition.[1]

## Why Use 3-PITC HBr?

- Enhanced Solubility: The hydrobromide salt form offers improved initial aqueous compatibility compared to the free base oils of BITC or PEITC.
- Structural Probe: It serves as a critical tool for Structure-Activity Relationship (SAR) studies, probing how the pyridine nitrogen's electron-withdrawing nature affects the electrophilicity of the ITC group compared to carbocyclic analogs.[1]

## Material Preparation & Handling[3]

CRITICAL SAFETY WARNING: Isothiocyanates are potent electrophiles and irritants. Handle in a fume hood. They react rapidly with nucleophiles (amines, thiols).[1]

## Stock Solution Preparation[3][4]

- Solvent: Dissolve 3-PITC HBr in anhydrous DMSO (Dimethyl Sulfoxide).
  - Note: Avoid ethanol or buffers containing amines (Tris, Glycine) for stock preparation, as they will react with the ITC group.[1]
- Concentration: Prepare a 100 mM master stock.
  - Calculation: MW = 231.11 g/mol .[1][2][3] Dissolve 23.11 mg in 1 mL DMSO.[1]
- Storage: Aliquot into small volumes (e.g., 50 µL) and store at -80°C. Stable for 6 months. Avoid repeated freeze-thaw cycles.

## Working Solutions

- Dilute the DMSO stock directly into pre-warmed culture media immediately prior to use.[1]

- Maximum DMSO: Ensure final DMSO concentration is <0.5% (v/v) to avoid solvent toxicity.
- Serum Interaction: ITCs bind albumin.[1] For precise kinetic studies, use serum-free or low-serum (1%) media.[1] For phenotypic assays, 10% FBS is acceptable but may shift the IC50 to higher values (2-5x).[1]

## Key Application: MIF Tautomerase Inhibition Assay

This protocol quantifies the ability of 3-PITC to inhibit the enzymatic activity of MIF. Since MIF's tautomerase site overlaps with its receptor-binding site, this assay is a surrogate for neutralizing MIF's biological activity.[1]

### Principle

MIF catalyzes the tautomerization of L-Dopachrome methyl ester (orange) to a colorless indole derivative. Inhibitors prevent this color loss.[1]

### Materials

- Recombinant Human MIF: 100 nM final concentration.[1]
- Substrate: L-Dopachrome methyl ester (freshly prepared from L-DOPA methyl ester and sodium periodate).
- Buffer: PBS, pH 7.4, containing 1 mM EDTA (Avoid Tris!).
- Detection: Absorbance at 475 nm.[1]

### Step-by-Step Protocol

- Substrate Prep: Mix 2.4 mM L-DOPA methyl ester with 4.8 mM Sodium Periodate (1:1 ratio) for 5 minutes at room temperature. Dilute 1:10 in assay buffer immediately before use.
- Inhibitor Incubation:
  - Add 180  $\mu$ L of Assay Buffer containing recombinant MIF (100 nM) to a 96-well plate.
  - Add 2  $\mu$ L of 3-PITC HBr (various concentrations: 0.1  $\mu$ M – 100  $\mu$ M).

- Control: DMSO vehicle only.[1]
- Incubate for 15 minutes at Room Temperature to allow covalent modification.
- Reaction Initiation: Add 20  $\mu$ L of the prepared L-Dopachrome substrate.
- Kinetic Read: Immediately monitor Absorbance at 475 nm every 10 seconds for 2 minutes.
- Analysis: Calculate the initial velocity ( ) of the decrease in OD475. Plot % Inhibition vs. Log[Concentration] to determine IC50.

Expected Result: 3-PITC HBr typically exhibits an IC50 in the low micromolar range (1–10  $\mu$ M), comparable to BITC.

## Key Application: Cell Viability & ROS Induction

Target Cells: A549 (Lung Cancer) or RAW 264.7 (Macrophage).

### Protocol: ROS Detection (DCFDA Assay)

- Seeding: Plate cells at cells/well in a black 96-well plate. Incubate overnight.
- Probe Loading: Wash cells with PBS.[1] Incubate with 10  $\mu$ M H2DCFDA (in serum-free media) for 30 minutes at 37°C.
- Treatment: Remove probe solution. Add media containing 3-PITC HBr (5, 10, 20  $\mu$ M).
- Measurement: Measure fluorescence (Ex/Em: 485/535 nm) at 1, 2, and 4 hours.
  - Note: Include NAC (N-acetylcysteine) (5 mM) pretreatment as a negative control to confirm ROS specificity.

### Data Visualization: MIF Signaling & ITC Mechanism

The following diagram illustrates how 3-PITC disrupts MIF signaling and induces oxidative stress.

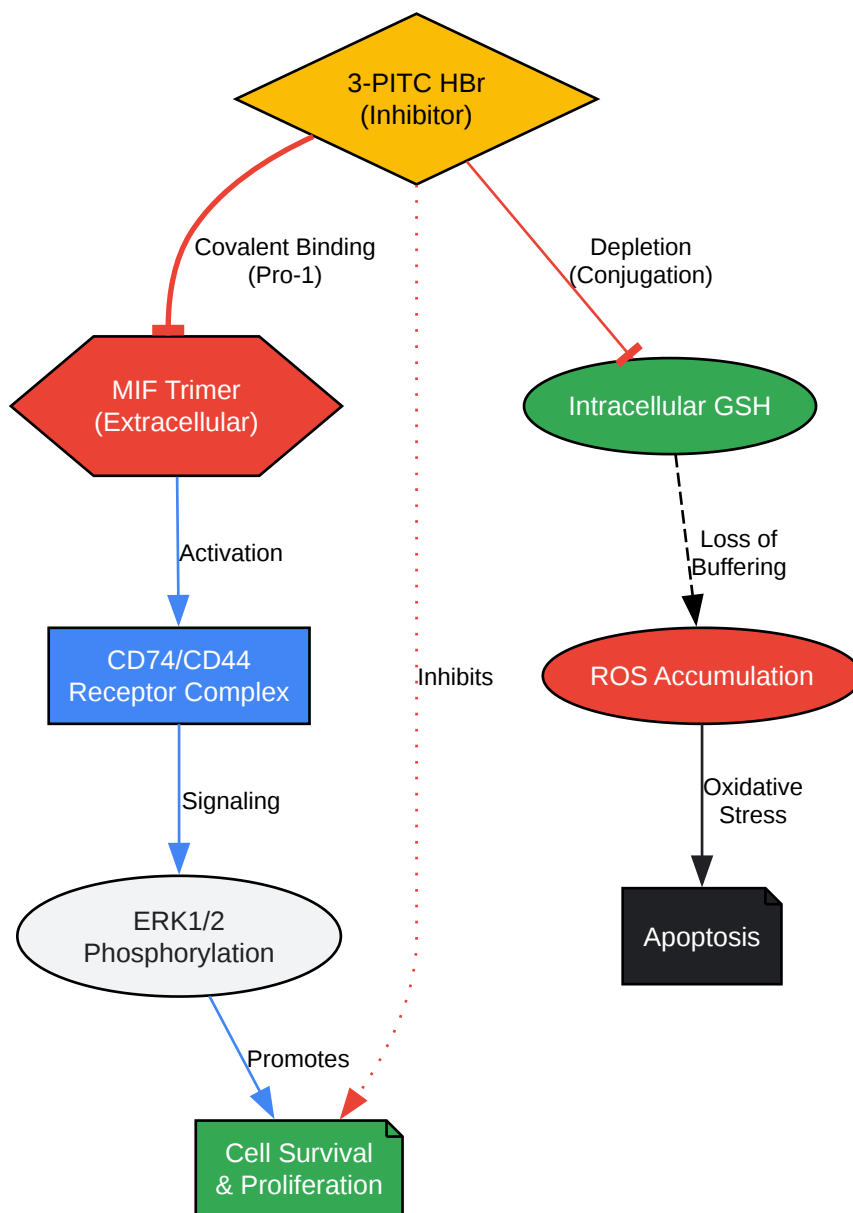

[Click to download full resolution via product page](#)

Caption: 3-PITC dual mechanism: blocking MIF-CD74 signaling and depleting GSH to induce apoptosis.[1]

## Experimental Workflow Diagram

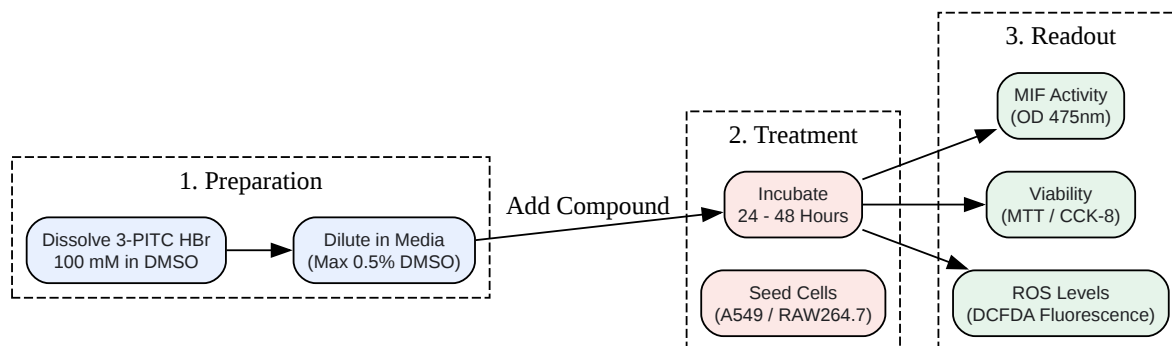

[Click to download full resolution via product page](#)

Caption: Standardized workflow for evaluating 3-PITC HBr bioactivity in cellular models.

## Summary of Key Parameters

Parameter	Specification	Notes
Primary Target	MIF Tautomerase Site	Covalent modification of N-terminal Proline.
IC50 (Enzymatic)	~1 - 10 $\mu$ M	Dependent on pre-incubation time (irreversible inhibitor).
Solubility	DMSO (100 mM)	HBr salt improves handling; avoid aqueous stock storage.
Stability	Low in amine buffers	Reacts with Tris/Glycine; use Phosphate/HEPES.[1]
Key Control	4-IPP or BITC	Use established MIF inhibitors as positive controls.[1]

## References

- MIF Inhibition by Isothiocyanates: Ou, L., et al. (2023).[1] "A new class of isothiocyanate-based irreversible inhibitors of Macrophage Migration Inhibitory Factor (MIF)." Journal of

## Biological Chemistry.

- Context: Establishes the structural basis for ITC-mediated inhibition of MIF via Pro-1 modific
- General ITC Mechanism: Zhang, Y. (2010).[1] "Allyl isothiocyanate as a cancer chemopreventive phytochemical." [1] Molecular Nutrition & Food Research.
  - Context: Reviews the glutathione depletion and ROS induction mechanisms common to the ITC class.
- MIF Tautomerase Assay Protocol: Swope, M., et al. (1998).[1] "Macrophage migration inhibitory factor interactions with oxidized catecholamines." EMBO Journal.[1]
  - Context: The foundational method for the Dopachrome Tautomerase assay used to valid
- H2S Donor Potential: Citi, V., et al. (2020).[1] "Structure-activity Relationships Study of Isothiocyanates for H2S Releasing Properties: 3-Pyridyl-Isothiocyanate as a New Promising Cardioprotective Agent." Journal of Advanced Research.
  - Context: Discusses the 3-pyridyl analog, providing context for the H2S-releasing potential of pyridine-based ITCs.

### Need Custom Synthesis?

BenchChem offers custom synthesis for rare earth carbides and specific isotopic labeling.

Email: [info@benchchem.com](mailto:info@benchchem.com) or [Request Quote Online](#).

## Sources

- [1. Cell Culture Select Tool | Thermo Fisher Scientific - HK \[thermofisher.com\]](#)
- [2. Analytical Chemistry \(836\) \[myskinrecipes.com\]](#)
- [3. 3-PICOLYL ISOTHIOCYANATE HYDROBROMIDE | 147342-57-2 \[chemicalbook.com\]](#)
- To cite this document: BenchChem. [Application Note: 3-Picolyl Isothiocyanate Hydrobromide in Cell-Based Assays]. BenchChem, [2026]. [Online PDF]. Available at: [\[https://www.benchchem.com/product/b139770/docs#application-note-3-picolyl-isothiocyanate-hydrobromide-in-cell-based-assays\]](https://www.benchchem.com/product/b139770/docs#application-note-3-picolyl-isothiocyanate-hydrobromide-in-cell-based-assays)

**Disclaimer & Data Validity:**

The information provided in this document is for Research Use Only (RUO) and is strictly not intended for diagnostic or therapeutic procedures. While BenchChem strives to provide accurate protocols, we make no warranties, express or implied, regarding the fitness of this product for every specific experimental setup.

**Technical Support:** The protocols provided are for reference purposes. Unsure if this reagent suits your experiment?

**Need Industrial/Bulk Grade?** [Request Custom Synthesis Quote](#)

## BenchChem

Our mission is to be the trusted global source of essential and advanced chemicals, empowering scientists and researchers to drive progress in science and industry.

### Contact

Address: 3281 E Guasti Rd  
Ontario, CA 91761, United States  
Phone: (601) 213-4426  
Email: [info@benchchem.com](mailto:info@benchchem.com)

[Contact our Ph.D. Support Team for a compatibility check](#)