

A Comparative Guide to Suzuki and Stille Couplings for Indole Functionalization

Author: BenchChem Technical Support Team. **Date:** May 2026

Compound of Interest

Compound Name: 1-Boc-3,5-Dibromoindole

CAS No.: 914349-23-8

Cat. No.: B1389188

[Get Quote](#)

For researchers, scientists, and professionals in drug development, the strategic functionalization of heterocyclic scaffolds like indole is a cornerstone of modern medicinal chemistry. The indole nucleus is a privileged structure, appearing in a vast array of natural products and pharmaceuticals.^{[1][2]} Consequently, efficient and reliable methods for its derivatization are of paramount importance. Among the arsenal of cross-coupling reactions, the Suzuki-Miyaura and Stille couplings have emerged as powerful tools for forging carbon-carbon bonds on the indole ring.^{[3][4]}

This guide provides an in-depth, objective comparison of these two stalwart reactions, moving beyond a simple recitation of protocols to explore the underlying mechanistic nuances, practical considerations, and strategic advantages of each. By understanding the causality behind experimental choices, researchers can make more informed decisions to accelerate their synthetic campaigns.

At a Glance: Key Comparative Metrics

Feature	Suzuki-Miyaura Coupling	Stille Coupling
Nucleophile	Organoboron compounds (boronic acids, esters, trifluoroborates)	Organotin compounds (organostannanes)
Toxicity	Low; boron reagents are generally considered environmentally benign.[5][6]	High; organotin reagents and byproducts are toxic.[7][8]
Reagent Stability	Boronic acids can be prone to protodeboronation, especially heteroaryl derivatives.[9][10] Aryltrifluoroborates offer enhanced stability.[9][11]	Organostannanes are generally stable to air and moisture.[8][12][13]
Reaction Conditions	Requires a base for activation of the boronic acid.[14] Generally mild conditions.[11]	Often proceeds under neutral, mild conditions.[12] Can be promoted by additives like Cu(I) salts.[13]
Functional Group Tolerance	Very high; tolerates a wide range of functional groups.[14]	Excellent; tolerates most common functional groups, including aldehydes, ketones, and esters.[15]
Byproduct Removal	Inorganic boron byproducts are typically water-soluble and easily removed.[6]	Organotin byproducts can be difficult to remove completely from the desired product.[12]
Substrate Scope	Extremely broad for aryl-aryl and aryl-vinyl couplings.[9] C(sp ³)-C(sp ²) couplings are more challenging but achievable.	Very broad, including aryl, vinyl, alkynyl, and allyl stannanes.[7]

The Catalytic Heart: A Mechanistic Overview

Both the Suzuki and Stille couplings are palladium-catalyzed reactions that proceed through a similar catalytic cycle, comprising three key steps: oxidative addition, transmetalation, and

reductive elimination.[16] Understanding the subtle differences in these steps is crucial to appreciating the distinct characteristics of each reaction.

Suzuki-Miyaura Coupling

The cycle begins with the oxidative addition of an organohalide (e.g., a haloindole) to a Pd(0) complex. A critical distinction of the Suzuki coupling is the necessity of a base to activate the organoboron reagent.[14] The base coordinates to the boron atom, forming a more nucleophilic "ate" complex, which facilitates the transfer of the organic group to the palladium center during the transmetalation step.[14][17] The cycle concludes with reductive elimination, which forms the new C-C bond and regenerates the active Pd(0) catalyst.[16][17]

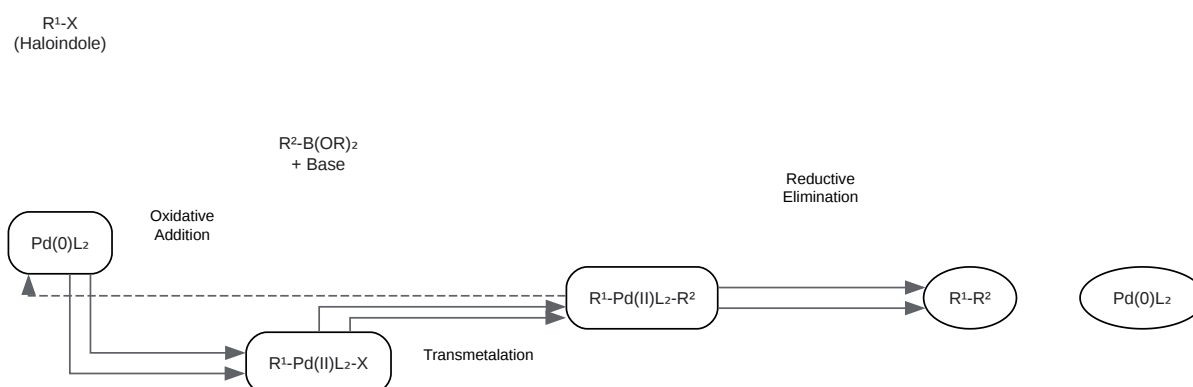

[Click to download full resolution via product page](#)

Caption: Catalytic cycle of the Suzuki-Miyaura coupling.

Stille Coupling

The Stille coupling follows a similar path, starting with the oxidative addition of the organohalide to Pd(0).[12] However, the transmetalation step involves an organostannane, which, unlike a boronic acid, does not typically require activation by a base.[7] The transfer of the organic group from tin to palladium proceeds directly. While the reaction is often run under neutral

conditions, additives like lithium chloride or copper(I) salts can accelerate the transmetalation step, particularly for less reactive substrates.[12] Reductive elimination then yields the coupled product and the Pd(0) catalyst.

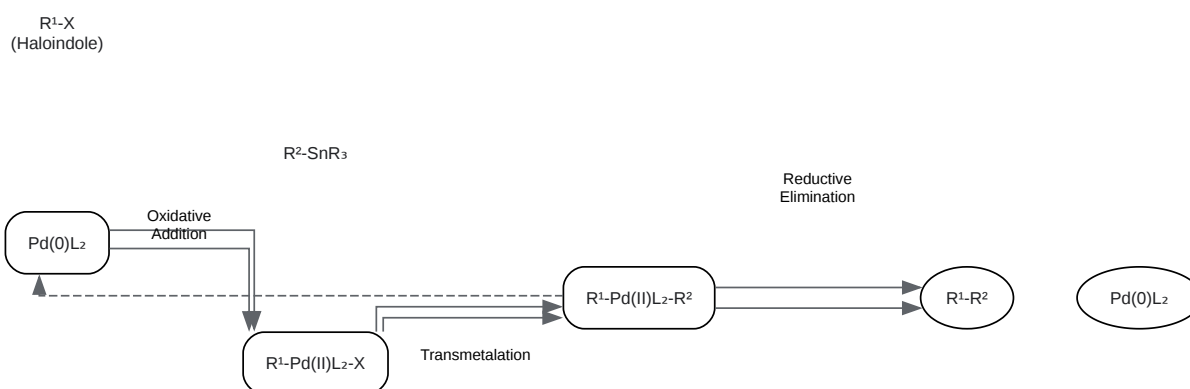

[Click to download full resolution via product page](#)

Caption: Catalytic cycle of the Stille coupling reaction.

Indole Functionalization: A Head-to-Head Comparison

The choice between Suzuki and Stille coupling for indole functionalization often depends on the specific position to be functionalized (e.g., C2, C3, or the benzene ring), the nature of the desired substituent, and the overall synthetic strategy.[18][19]

C2 and C3 Arylation: The Core Reactivity

Both methods are widely used for the arylation of pre-functionalized indoles (e.g., haloindoles).

- Suzuki Coupling: This is often the go-to method for C2 and C3 arylation due to the commercial availability of a vast library of boronic acids and the low toxicity of the reagents.

[1][9] The reaction conditions are generally mild, and the purification is straightforward.[6][11] However, the stability of indolylboronic acids can be a concern, and direct C-H activation/Suzuki coupling is an increasingly popular alternative to using pre-halogenated indoles.[1]

- Stille Coupling: The Stille reaction demonstrates excellent functional group tolerance, making it highly valuable in complex molecule synthesis.[15] The air and moisture stability of organostannanes is a significant practical advantage.[8][13] The primary drawback is the toxicity of tin compounds and the potential for tin residues in the final product, which is a major concern in pharmaceutical development.[7][10]

A comparative study on the functionalization of diazocines (related azo-macrocycles) showed that for electron-rich and simple aromatic electrophiles, both Suzuki and Stille couplings gave high yields.[20] However, for substrates with strongly coordinating groups like aldehydes or esters, the Stille coupling consistently provided higher yields, whereas the Suzuki coupling's performance was diminished.[20] This highlights a key advantage of the Stille reaction: its robustness in the presence of potentially problematic functional groups.

Experimental Workflow: A Practical Viewpoint

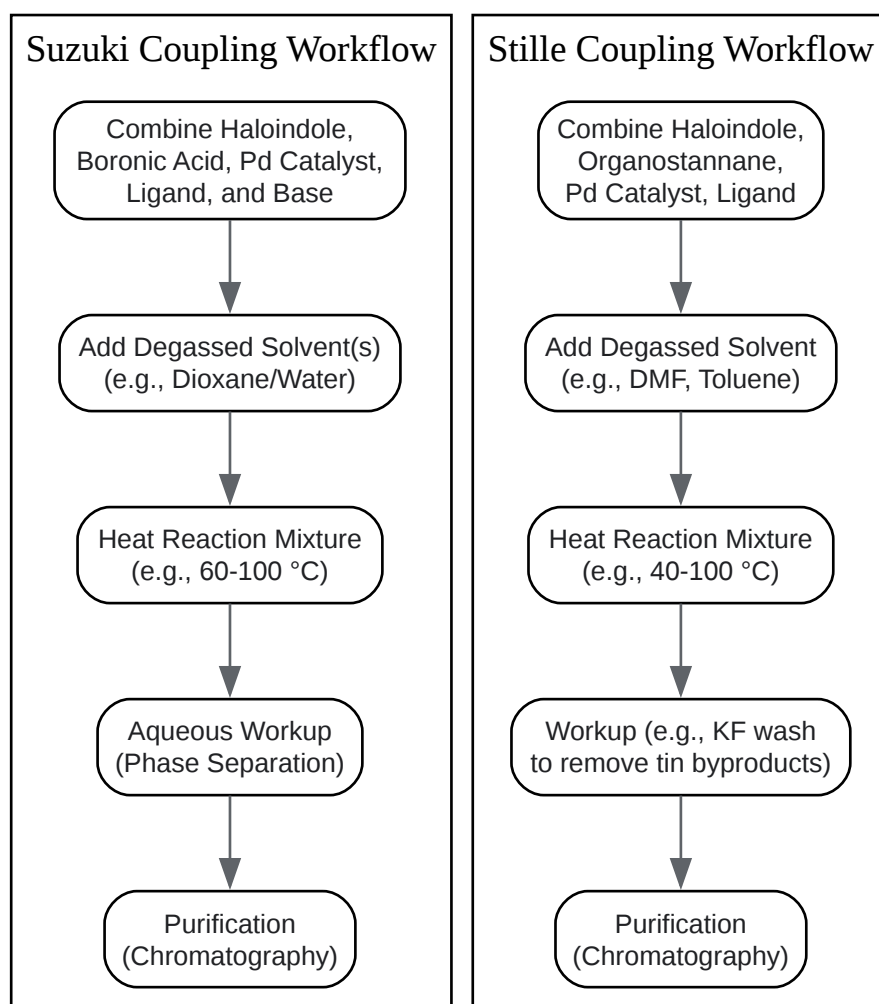

[Click to download full resolution via product page](#)

Caption: Comparative experimental workflows for Suzuki vs. Stille coupling.

Field-Proven Insights & Causality

Why choose Suzuki? The primary driver is safety and environmental friendliness.^[6] The low toxicity of boronic acids and their byproducts makes the Suzuki coupling highly attractive for industrial-scale synthesis and pharmaceutical applications.^[11] The ease of byproduct removal simplifies purification protocols. Furthermore, the sheer diversity of commercially available boronic acids provides unparalleled access to a wide range of chemical space.^[9]

When is Stille the better choice? Despite its toxicity concerns, the Stille coupling remains indispensable in certain scenarios. Its key advantage lies in the stability and reliability of

organostannane reagents, especially for complex or sensitive heterocyclic systems where the corresponding boronic acids might be unstable and prone to decomposition.^[10] The reaction's high tolerance for a vast array of functional groups and its typically neutral conditions can make it the more robust and higher-yielding option for intricate, late-stage functionalizations in total synthesis.^[15] For particularly electron-deficient or coordinating heterocycles, Stille coupling often outperforms Suzuki.^{[10][20]}

Representative Experimental Protocols

Protocol 1: Suzuki-Miyaura C2-Arylation of 3-Methylindole

This protocol is adapted from a procedure for the direct C-H arylation of indoles.^[1]

Materials:

- N-protected or unprotected 3-methylindole (1.0 mmol)
- Aryl boronic acid (1.2 mmol)
- Pd(OAc)₂ (Palladium(II) acetate) (0.05 mmol, 5 mol%)
- SPhos (Ligand) (0.1 mmol, 10 mol%)
- K₃PO₄ (Potassium phosphate) (2.0 mmol)
- Toluene (5 mL) and Water (0.5 mL), degassed

Procedure:

- To a flame-dried Schlenk tube, add the indole, aryl boronic acid, Pd(OAc)₂, SPhos, and K₃PO₄.
- Seal the tube with a septum, and purge with argon for 10-15 minutes.
- Add the degassed toluene and water via syringe.

- Place the reaction vessel in a preheated oil bath at 80 °C and stir for 12-24 hours, monitoring by TLC or LC-MS.
- Upon completion, cool the reaction to room temperature. Dilute with ethyl acetate (20 mL) and wash with water (2 x 10 mL) and brine (1 x 10 mL).
- Dry the organic layer over anhydrous Na₂SO₄, filter, and concentrate under reduced pressure.
- Purify the crude product by flash column chromatography on silica gel to yield the desired 2-aryl-3-methylindole.

Protocol 2: Stille C3-Arylation of 2-Methyl-3-iodoindole

This protocol is a general representation of a Stille coupling procedure.[\[12\]](#)

Materials:

- 2-Methyl-3-iodoindole (1.0 mmol)
- Aryltributylstannane (1.1 mmol)
- Pd(PPh₃)₄ (Tetrakis(triphenylphosphine)palladium(0)) (0.03 mmol, 3 mol%)
- Anhydrous, degassed N,N-Dimethylformamide (DMF) (5 mL)
- (Optional) CuI (Copper(I) iodide) (0.1 mmol, 10 mol%)

Procedure:

- To a flame-dried Schlenk tube, add the 2-methyl-3-iodoindole and Pd(PPh₃)₄ (and CuI, if used).
- Seal the tube, evacuate, and backfill with argon (repeat three times).
- Add the degassed DMF via syringe, followed by the aryltributylstannane.
- Heat the reaction mixture to 80-100 °C and stir for 4-12 hours, monitoring by TLC or LC-MS.

- After cooling to room temperature, dilute the mixture with diethyl ether (25 mL).
- Wash the solution with a saturated aqueous solution of KF (potassium fluoride) (3 x 15 mL) to precipitate tin byproducts. Stir vigorously for 30 minutes during each wash.
- Filter the mixture through a pad of Celite to remove the precipitate.
- Wash the filtrate with brine, dry over anhydrous MgSO_4 , filter, and concentrate.
- Purify the residue by flash column chromatography to afford the 3-aryl-2-methylindole.

Conclusion

Both the Suzuki-Miyaura and Stille couplings are formidable and versatile methods for the functionalization of indoles. The Suzuki coupling is generally favored due to its low toxicity, wide availability of reagents, and straightforward purification, making it a workhorse for both discovery and process chemistry. However, the Stille coupling's exceptional functional group tolerance and the stability of its organometallic reagents ensure its continued and critical role in complex synthesis, particularly when other methods fall short. The judicious selection between these two powerful reactions, based on a clear understanding of their respective strengths and weaknesses, is a hallmark of strategic and efficient chemical synthesis.

References

- Suzuki-Miyaura Coupling - Chemistry LibreTexts. (2024). Chemistry LibreTexts. [\[Link\]](#)
- Stille Coupling - Organic Chemistry Portal. Organic Chemistry Portal. [\[Link\]](#)
- Suzuki Coupling - Organic Chemistry Portal. Organic Chemistry Portal. [\[Link\]](#)
- Pd-catalyzed C–H bond activation of Indoles for Suzuki reaction. (2019). Indian Academy of Sciences. [\[Link\]](#)
- Suzuki reaction - Wikipedia. Wikipedia. [\[Link\]](#)
- Suzuki-Miyaura Cross-Coupling of Unprotected, Nitrogen-Rich Heterocycles: Substrate Scope and Mechanistic Investigation. (2012). NIH National Center for Biotechnology Information. [\[Link\]](#)

- Palladium-Catalyzed Dearomative Heck/Suzuki Coupling of C2-Deuterated or C2-Nonsubstituted Indoles. (2024). ACS Publications. [\[Link\]](#)
- Stille Coupling | OpenOChem Learn. OpenOChem Learn. [\[Link\]](#)
- Elucidating the Role of the Boronic Esters in the Suzuki–Miyaura Reaction: Structural, Kinetic, and Computational Investigations. (2013). NIH National Center for Biotechnology Information. [\[Link\]](#)
- Suzuki Coupling Mechanism and Applications. (2018). YouTube. [\[Link\]](#)
- Suzuki Coupling Mechanism. (2022). YouTube. [\[Link\]](#)
- Stille reaction - Justapedia. Justapedia. [\[Link\]](#)
- Synthesis and Functionalization of Indoles Through Palladium-catalyzed Reactions. (2004). ACS Publications. [\[Link\]](#)
- Stille reaction - Wikipedia. Wikipedia. [\[Link\]](#)
- The Mechanisms of the Stille Reaction. (2004). University of Windsor. [\[Link\]](#)
- Stille Coupling | NROChemistry. NROChemistry. [\[Link\]](#)
- Stille vs. Suzuki – cross-coupling for the functionalization of diazocines. (2023). NIH National Center for Biotechnology Information. [\[Link\]](#)
- a) Suzuki coupling reaction of azaindole derivatives. b) The mechanism.... ResearchGate. [\[Link\]](#)
- Transition Metal-Free C3 Arylation of Indoles with Aryl Halides. (2017). NIH National Center for Biotechnology Information. [\[Link\]](#)
- The Stille Reaction - Organic Reactions. Organic Reactions. [\[Link\]](#)
- Suzuki Coupling: Mechanism & Examples | NROChemistry. NROChemistry. [\[Link\]](#)
- Stille Coupling - Chemistry LibreTexts. (2023). Chemistry LibreTexts. [\[Link\]](#)

- An indole-amide-based phosphine ligand enabling a general palladium-catalyzed sterically hindered Suzuki–Miyaura cross-coupling reaction. (2021). Royal Society of Chemistry. [\[Link\]](#)
- Recoverable Palladium-Catalyzed Carbon-Carbon Bond Forming Reactions under Thermomorphic Mode: Stille and Suzuki-Miyaura Reactions. (2021). NIH National Center for Biotechnology Information. [\[Link\]](#)
- From C4 to C7: Innovative Strategies for Site-Selective Functionalization of Indole C–H Bonds. ResearchGate. [\[Link\]](#)
- Palladium-Catalyzed Dearomative Heck/Suzuki Coupling of C2-Deuterated or C2-Nonsubstituted Indoles. (2024). PubMed. [\[Link\]](#)
- Is the Stille Reaction Useful?. (2024). YouTube. [\[Link\]](#)
- Arylation of indole at C2 catalyzed by palygorskite grafted covalent organic frameworks supported palladium catalyst. ResearchGate. [\[Link\]](#)
- Recent Advances in the development of Suzuki Miyaura Coupling Reactions. (2018). WWJMRD. [\[Link\]](#)
- C3-Arylation of indoles with aryl ketones via C–C/C–H activations. (2018). Royal Society of Chemistry. [\[Link\]](#)
- Palladium-catalyzed dual C–H or N–H functionalization of unfunctionalized indole derivatives with alkenes and arenes. (2012). Beilstein Journals. [\[Link\]](#)
- A Short Review of C7 – H Bond Functionalization of Indole/Indoline. (2024). RSIS International. [\[Link\]](#)
- C3-Selective Arylation of Indoles Using Palladium-Hydroxyterphenylphosphine Catalysts and Its Application to Syntheses of Nitrogen-containing Polycyclic Compounds. ResearchGate. [\[Link\]](#)
- Direct Palladium-Catalyzed C-2 and C-3 Arylation of Indoles: A Mechanistic Rationale for Regioselectivity. (2006). ACS Publications. [\[Link\]](#)

- Stille Cross-Coupling of Activated Alkyltin Reagents under “Ligandless” Conditions. (2005). ACS Publications. [[Link](#)]
- Metal-Catalyzed Cross-Coupling Reactions on Azaindole Synthesis and Functionalization. (2018). MDPI. [[Link](#)]
- Synthesis of Indoles via Intermolecular and Intramolecular Cyclization by Using Palladium-Based Catalysts. (2022). MDPI. [[Link](#)]
- Direct Palladium-Catalyzed C-3 Arylation of Indoles. (2007). ResearchGate. [[Link](#)]

Need Custom Synthesis?

BenchChem offers custom synthesis for rare earth carbides and specific isotopic labeling.

Email: info@benchchem.com or [Request Quote Online](#).

Sources

- 1. ias.ac.in [ias.ac.in]
- 2. rsisinternational.org [rsisinternational.org]
- 3. pubs.acs.org [pubs.acs.org]
- 4. wwjmr.com [wwjmr.com]
- 5. Elucidating the Role of the Boronic Esters in the Suzuki–Miyaura Reaction: Structural, Kinetic, and Computational Investigations - PMC [pmc.ncbi.nlm.nih.gov]
- 6. m.youtube.com [m.youtube.com]
- 7. Stille Coupling [organic-chemistry.org]
- 8. Stille reaction - Wikipedia [en.wikipedia.org]
- 9. Suzuki reaction - Wikipedia [en.wikipedia.org]
- 10. youtube.com [youtube.com]
- 11. chem.libretexts.org [chem.libretexts.org]
- 12. Stille Coupling | NROChemistry [nrochemistry.com]
- 13. organicreactions.org [organicreactions.org]

- [14. Suzuki Coupling \[organic-chemistry.org\]](#)
- [15. uwindsor.ca \[uwindsor.ca\]](#)
- [16. Suzuki Coupling: Mechanism & Examples | NROChemistry \[nrochemistry.com\]](#)
- [17. m.youtube.com \[m.youtube.com\]](#)
- [18. researchgate.net \[researchgate.net\]](#)
- [19. pubs.acs.org \[pubs.acs.org\]](#)
- [20. Stille vs. Suzuki – cross-coupling for the functionalization of diazocines - PMC \[pmc.ncbi.nlm.nih.gov\]](#)
- To cite this document: BenchChem. [A Comparative Guide to Suzuki and Stille Couplings for Indole Functionalization]. BenchChem, [2026]. [Online PDF]. Available at: [\[https://www.benchchem.com/product/b1389188/docs#a-comparative-guide-to-suzuki-and-stille-couplings-for-indole-functionalization\]](https://www.benchchem.com/product/b1389188/docs#a-comparative-guide-to-suzuki-and-stille-couplings-for-indole-functionalization)

Disclaimer & Data Validity:

The information provided in this document is for Research Use Only (RUO) and is strictly not intended for diagnostic or therapeutic procedures. While BenchChem strives to provide accurate protocols, we make no warranties, express or implied, regarding the fitness of this product for every specific experimental setup.

Technical Support: The protocols provided are for reference purposes. Unsure if this reagent suits your experiment?

Need Industrial/Bulk Grade? [Request Custom Synthesis Quote](#)

BenchChem

Our mission is to be the trusted global source of essential and advanced chemicals, empowering scientists and researchers to drive progress in science and industry.

Contact

Address: 3281 E Guasti Rd

Ontario, CA 91761, United States

Phone: (601) 213-4426

Email: info@benchchem.com

Contact our Ph.D. Support Team for a compatibility check