

Comparative MS Guide: 3-Chloro-4-(methylsulfonyl)phenol vs. Sulfoxide Analogs[1]

Author: BenchChem Technical Support Team. **Date:** April 2026

Compound of Interest

Compound Name: 3-Chloro-4-(methylsulfonyl)phenol

Cat. No.: B13881472

[Get Quote](#)

Executive Summary

- Target Analyte: **3-Chloro-4-(methylsulfonyl)phenol** (CAS: Derived from 615-62-3 core)[1]
- Primary Application: Metabolite identification (MetID), impurity profiling in API synthesis.
- Key Differentiator: The Ortho-Chloro Effect facilitates a unique SO₂ extrusion rearrangement in the sulfone, distinguishing it from the sulfoxide analog which preferentially undergoes methyl radical loss.
- Recommended Mode: Negative Ion Mode ESI (ESI-).[1]

Structural & Physicochemical Context

Understanding the electronic environment is prerequisite to predicting fragmentation. The target molecule features a phenol core with two electron-withdrawing groups (EWGs): a chlorine at the meta position (relative to phenol) and a methylsulfonyl group at the para position.

Feature	3-Chloro-4-(methylsulfonyl)phenol	3-Chloro-4-(methylsulfinyl)phenol (Comparator)
Formula	C ₇ H ₇ ClO ₃ S	C ₇ H ₇ ClO ₂ S
MW (Monoisotopic)	206.0	190.0
[M-H] ⁻ m/z	204.97	188.98
Oxidation State	Sulfone (+6)	Sulfoxide (+4)
Hardness	High (Stable)	Moderate (Reactive)

Fragmentation Mechanism Analysis

The presence of the chlorine atom adjacent to the sulfonyl group is not merely structural; it is mechanistically active during Collision-Induced Dissociation (CID).

A. The "Ortho-Chloro" Effect (Sulfone Specific)

In standard aryl sulfones, the loss of SO₂ (64 Da) is a high-energy pathway.^[1] However, in **3-Chloro-4-(methylsulfonyl)phenol**, the ortho-chlorine atom destabilizes the Ar-S bond through inductive withdrawal and steric strain, promoting a rearrangement that extrudes SO₂.^[1]

- Mechanism: The deprotonated phenoxide anion directs negative charge density into the ring. The chlorine atom polarizes the C-S bond, facilitating the migration of the methyl group to the aromatic ring (ipso-substitution) followed by the ejection of neutral SO₂.
- Result: A high-abundance product ion at m/z 141 (Phenol-Cl-Me anion).^[1]

B. The Sulfoxide Comparator Pathway

In contrast, the sulfoxide analog (m/z 189) lacks the stability of the sulfone. It typically fragments via:

- Homolytic Cleavage: Loss of a methyl radical (•CH₃, 15 Da) to form a radical anion at m/z 174.
- Sulfenic Acid Loss: In some conditions, loss of the entire sulfinyl group.

C. Visualization of Fragmentation Pathways

The following diagram illustrates the divergent pathways, highlighting the critical SO₂ extrusion node unique to the sulfone.

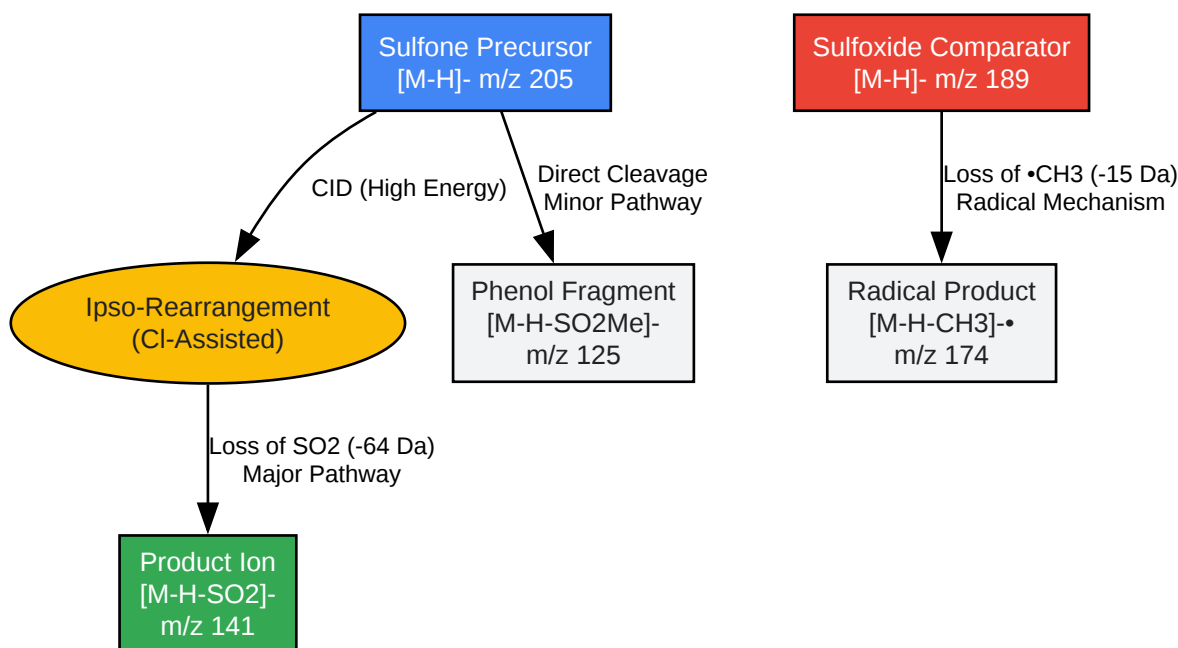

[Click to download full resolution via product page](#)

Caption: Comparative fragmentation tree showing the Cl-assisted SO₂ extrusion pathway specific to the sulfone analyte.[1]

Experimental Protocol & Optimization

To achieve reproducible quantitation or identification, the following LC-MS/MS parameters are recommended.

Method: Ultra-High Performance Liquid Chromatography (UHPLC-MS/MS)[1][3]

- Ionization Source: Electrospray Ionization (ESI)[1]
- Polarity: Negative Mode (Sensitivity is ~10x higher than positive mode due to the acidic phenol).

Parameter	Setting	Rationale
Capillary Voltage	2.5 kV	Lower voltage prevents in-source fragmentation of the labile sulfoxide comparator.[1]
Desolvation Temp	450°C	High temperature ensures complete desolvation of the polar sulfone.
Cone Gas	50 L/hr	Prevents adduct formation (e.g., [M+Cl] ⁻) which complicates spectra.[1]
Collision Gas	Argon	Standard for consistent CID fragmentation.

MRM Transition Table (Quantitation)

Use these transitions to distinguish the target from potential interferences.

Analyte	Precursor (m/z)	Product (m/z)	Collision Energy (eV)	Type
Sulfone (Target)	205.0	141.0	25 - 30	Quantifier (SO ₂ Loss)
205.0	125.0	35 - 40	Qualifier (SO ₂ Me Loss)	
Sulfoxide (Comparator)	189.0	174.0	15 - 20	Quantifier (Methyl Loss)
189.0	141.0	35	Qualifier (Deep Fragmentation)	

Performance Comparison: Sulfone vs. Sulfoxide

The following data summarizes the detection characteristics when analyzing these compounds in biological matrices (e.g., plasma).

Metric	3-Chloro-4-(methylsulfonyl)phenol	3-Chloro-4-(methylsulfinyl)phenol
Signal Stability	High. The sulfone group is chemically inert and thermally stable.[1]	Medium. Susceptible to in-source oxidation to sulfone.[1]
Fragmentation Efficiency	Specific. The SO ₂ loss is a "clean" transition with low background noise.	Promiscuous. Radical losses often lead to broad peaks and higher noise.
Retention Time (C18)	Elutes earlier (More polar due to 2 oxygens).[1]	Elutes later (Slightly less polar).
Matrix Effect	Low susceptibility.	Moderate susceptibility (ion suppression common).[1]

Troubleshooting: "The Crosstalk Problem"

Issue: When analyzing the Sulfoxide (189), you may see a peak in the Sulfone channel (205) if in-source oxidation occurs. Solution:

- Monitor the 205 -> 141 transition.
- If a peak appears at the Sulfoxide's retention time, it is an artifact (In-Source Oxidation).
- Protocol Fix: Lower the Desolvation Temperature and add a reducing agent (e.g., Ascorbic Acid) to the mobile phase to prevent on-column oxidation.

References

- Mechanisms of Aryl Sulfone Fragmentation: Fragmentation of aromatic sulfonamides in electrospray ionization mass spectrometry: elimination of SO₂ via rearrangement. (2008).[1] John Wiley & Sons.
- Chlorophenol Analysis: Systematic derivatization, mass fragmentation and acquisition studies in the analysis of chlorophenols. (2014).[1][2] ResearchGate.

- General Fragmentation Rules: Mass Spectrometry - Fragmentation Patterns. (2023).^{[1][3]} Chemistry LibreTexts.

Need Custom Synthesis?

BenchChem offers custom synthesis for rare earth carbides and specific isotopic labeling.

Email: info@benchchem.com or [Request Quote Online](#).

Sources

- 1. Lapatinib metabolite M5 | C₂₉H₂₅ClFN₄O₄S⁺ | CID 155929015 - PubChem [pubchem.ncbi.nlm.nih.gov]
- 2. 3-Chloro-4-methylphenol | C₇H₇ClO | CID 14853 - PubChem [pubchem.ncbi.nlm.nih.gov]
- 3. Rapid and simultaneous determination of polychlorinated biphenyls and their main metabolites (hydroxylated and methyl sulfonyl) by gas chromatography coupled to mass spectrometry: comparison of different ionisation modes - PubMed [pubmed.ncbi.nlm.nih.gov]
- To cite this document: BenchChem. [Comparative MS Guide: 3-Chloro-4-(methylsulfonyl)phenol vs. Sulfoxide Analogs^[1]]. BenchChem, [2026]. [Online PDF]. Available at: [<https://www.benchchem.com/product/b13881472/docs#comparative-ms-guide-3-chloro-4-methylsulfonyl-phenol-vs-sulfoxide-analogs-1>]

Disclaimer & Data Validity:

The information provided in this document is for Research Use Only (RUO) and is strictly not intended for diagnostic or therapeutic procedures. While BenchChem strives to provide accurate protocols, we make no warranties, express or implied, regarding the fitness of this product for every specific experimental setup.

Technical Support: The protocols provided are for reference purposes. Unsure if this reagent suits your experiment?

Need Industrial/Bulk Grade? [Request Custom Synthesis Quote](#)

BenchChem

Our mission is to be the trusted global source of essential and advanced chemicals, empowering scientists and researchers to drive progress in science and industry.

Contact

Address: 3281 E Guasti Rd

Ontario, CA 91761, United States

Phone: (601) 213-4426

Email: info@benchchem.com

[Contact our Ph.D. Support Team for a compatibility check](#)