

# Application Note: Navigating the Landscape of Label-Free Interaction Analysis

**Author:** BenchChem Technical Support Team. **Date:** April 2026

## Compound of Interest

Compound Name: 2-[1-(2-Hydroxy-ethylamino)-ethyl]-phenol oxalate

CAS No.: 1185300-79-1

Cat. No.: B1388940

[Get Quote](#)

## Introduction: The Imperative for Label-Free Analysis in Drug Discovery

In the intricate process of drug discovery, the precise characterization of interactions between small molecule candidates and their protein targets is paramount. Historically, this has involved labeling one of the binding partners with a fluorescent or radioactive tag. However, such modifications can inadvertently alter the molecule's structure and binding behavior, leading to potentially misleading data.<sup>[1]</sup> Label-free technologies circumvent this fundamental problem by detecting the intrinsic biophysical changes that occur upon binding, such as alterations in mass, heat, or movement.<sup>[2][3]</sup> This approach provides a more authentic and physiologically relevant measurement of binding events, reducing artifacts and expanding the range of compatible targets.<sup>[2][3]</sup> This guide provides a comprehensive overview of the principles, protocols, and field-proven insights for the leading label-free quantification (LFQ) methods, empowering researchers to select and execute the optimal strategy for their scientific questions.

# Chapter 1: Selecting the Optimal Technique: A Comparative Overview

The choice of a label-free method is a critical decision that influences the type and quality of data obtained. No single technique is universally superior; the selection depends on the specific goals of the experiment, the nature of the interactants, and the stage of the drug discovery pipeline.<sup>[4][5]</sup> The four most prominent techniques—Surface Plasmon Resonance (SPR), Bio-Layer Interferometry (BLI), Isothermal Titration Calorimetry (ITC), and Microscale Thermophoresis (MST)—each offer a unique set of advantages and limitations.<sup>[6][7][8]</sup>

Causality Behind the Choice:

- For kinetics and affinity in real-time: SPR and BLI are the go-to methods. SPR is often considered the "gold standard" for high-quality kinetic data, while BLI offers higher throughput, making it suitable for earlier-stage screening.<sup>[6][7][9]</sup>
- For thermodynamic data: ITC is unparalleled. It directly measures the heat of binding, providing a complete thermodynamic profile ( $\Delta H$ ,  $\Delta S$ ) in a single, in-solution experiment, which is crucial for understanding the driving forces of the interaction.<sup>[4][10][11]</sup>
- For low sample consumption and in-solution measurements: MST is a powerful option, requiring minimal sample volume and avoiding surface immobilization, which can sometimes inactivate proteins.<sup>[12][13][14]</sup>

Table 1: Comparative Analysis of Key Label-Free Technologies

Feature	Surface Plasmon Resonance (SPR)	Bio-Layer Interferometry (BLI)	Isothermal Titration Calorimetry (ITC)	Microscale Thermophoresis (MST)
Primary Output	Kinetics ( $k_a$ , $k_d$ ), Affinity ( $K_D$ )	Kinetics ( $k_a$ , $k_d$ ), Affinity ( $K_D$ )	Affinity ( $K_D$ ), Thermodynamics ( $\Delta H$ , $\Delta S$ ), Stoichiometry ( $n$ )	Affinity ( $K_D$ )
Immobilization	Required (Ligand on sensor)	Required (Ligand on biosensor tip)	Not required (in-solution)	Not required (in-solution)
Throughput	Medium to High	High	Low to Medium	High
Sample Consumption	Low to Medium	Low	High	Very Low
Small Molecule Limit	~100 Da	~150 Da <sup>[15]</sup>	No theoretical limit	No theoretical limit
Key Advantage	High-quality, real-time kinetic data; regulatory acceptance. <sup>[6][7]</sup>	High throughput, crude sample compatibility, lower maintenance. <sup>[6][7]</sup>	"Gold standard" for thermodynamics; no immobilization. <sup>[4][10]</sup>	Very low sample usage; fast; tolerant of complex buffers. <sup>[13][14][16]</sup>
Key Limitation	Potential for protein inactivation upon immobilization; requires microfluidics.	Lower sensitivity for small molecules compared to SPR.	High sample consumption; sensitive to buffer mismatches.	Requires fluorescence (intrinsic or extrinsic label). <sup>[7][16]</sup>

## Chapter 2: Surface Plasmon Resonance (SPR)

SPR is an optical technique that measures molecular interactions in real-time by detecting changes in the refractive index near a sensor surface.<sup>[17][18]</sup> It is highly sensitive and provides detailed information on both the kinetics and affinity of an interaction.<sup>[7]</sup>

## Principle of Operation

In a typical SPR experiment, a protein (the ligand) is immobilized on a gold-coated sensor chip. [17] Polarized light is directed at the chip, and at a specific angle—the resonance angle—surface plasmons are excited, causing a dip in the intensity of reflected light. When a small molecule (the analyte) flows over the surface and binds to the ligand, the mass at the surface increases, changing the local refractive index. This change shifts the resonance angle, which is recorded in real-time as a response in Resonance Units (RU). [17]

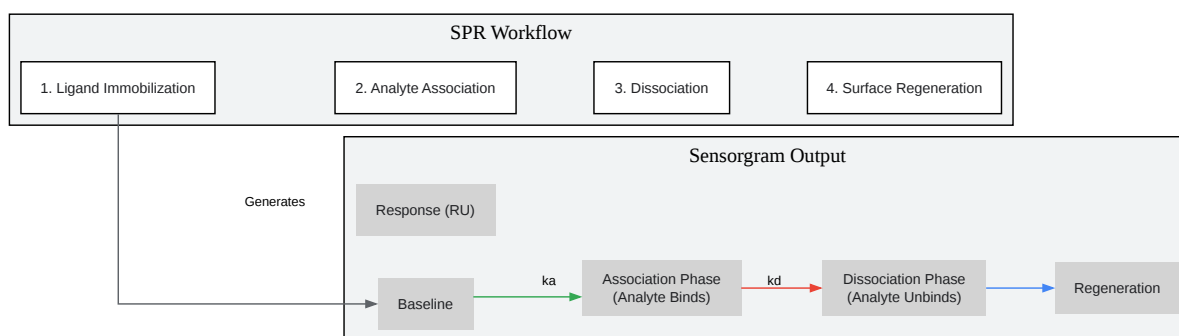

[Click to download full resolution via product page](#)

Caption: SPR experimental workflow and the resulting sensorgram.

## Application Note: The Rationale for SPR

SPR is the method of choice when high-resolution kinetic data is essential. The ability to accurately determine both the on-rate ( $k_a$ ) and off-rate ( $k_d$ ) provides deep mechanistic insight into the binding event. [5] For example, two compounds with the same affinity ( $K_d$ ) might have vastly different kinetics; one may bind and release quickly, while another binds slowly but remains bound for a long time (a slow off-rate). This distinction is critical in drug development, as a longer drug-target residence time often correlates with improved efficacy. SPR's precision has made it a benchmark technique accepted by regulatory agencies. [6]

## Detailed Protocol: SPR Analysis of a Protein-Small Molecule Interaction

This protocol assumes the use of a standard amine coupling chemistry for protein immobilization onto a CM5 sensor chip.

### 1. Materials & Reagents:

- Protein (Ligand): >95% purity, in a suitable buffer (e.g., 10 mM Acetate, pH 4.0-5.5).
- Small Molecule (Analyte): Solubilized in running buffer, typically with  $\leq 1\%$  DMSO.
- Running Buffer: e.g., HBS-EP+ (10 mM HEPES pH 7.4, 150 mM NaCl, 3 mM EDTA, 0.05% v/v Surfactant P20).
- Immobilization Kit: Amine coupling kit containing NHS, EDC, and ethanolamine.
- Regeneration Solution: A solution that removes the analyte without denaturing the ligand (e.g., low pH glycine, high salt).

### 2. Experimental Procedure:

- Step 1: Surface Preparation & Immobilization
  - System Priming: Prime the instrument with running buffer until a stable baseline is achieved.
  - pH Scouting (Optional but Recommended): To optimize immobilization, inject the protein over the sensor surface in a series of buffers with different pH values (e.g., Acetate pH 4.0, 4.5, 5.0). The optimal pH is typically 0.5 units below the protein's pI, promoting electrostatic pre-concentration.
  - Surface Activation: Inject a 1:1 mixture of NHS/EDC for 7 minutes to activate the carboxymethylated dextran surface.[\[19\]](#)
  - Ligand Injection: Inject the protein solution over the activated surface until the desired immobilization level is reached (typically 100 RU per kDa of analyte molecular weight for

small molecule analysis).

- Deactivation: Inject ethanolamine to deactivate any remaining active esters on the surface.
- Step 2: Analyte Binding Assay (Kinetics)
  - Baseline Establishment: Flow running buffer over the immobilized surface until a stable signal is achieved.
  - Analyte Injection (Association): Inject the small molecule analyte at a specific concentration for a defined period (e.g., 60-180 seconds) to monitor the binding event. A concentration series (e.g., 5-7 concentrations, typically spanning 0.1x to 10x the expected  $K_D$ ) should be run, including a zero-concentration (buffer only) injection for double referencing.
  - Buffer Injection (Dissociation): Switch back to flowing running buffer and monitor the signal decrease as the analyte dissociates from the ligand (e.g., for 120-600 seconds).[18]
- Step 3: Surface Regeneration
  - Inject a short pulse of the optimized regeneration solution to remove all bound analyte.
  - Flow running buffer to ensure the baseline returns to its initial state, indicating the ligand's activity is preserved.

### 3. Data Analysis:

- Data Processing: Perform double-referencing by subtracting the signal from a reference flow cell (without immobilized protein) and the signal from a buffer-only injection. This corrects for bulk refractive index changes and instrument drift.
- Model Fitting: Fit the processed sensorgrams to a suitable binding model (e.g., 1:1 Langmuir binding model) using the instrument's software to derive  $k_a$ ,  $k_d$ , and  $K_D$ .

## Troubleshooting Common SPR Issues[20]

Issue	Potential Cause(s)	Recommended Solution(s)
No/Low Binding	Inactive immobilized protein; incorrect analyte concentration.	Confirm protein activity with a known binder; check protein orientation (consider capture-based immobilization); verify analyte concentration and solubility.
Non-Specific Binding	Analyte binds to the sensor matrix, not the ligand.	Increase salt concentration in running buffer; add 0.1% BSA or other blocking agent; include a small percentage of organic solvent (e.g., DMSO) if analyte is hydrophobic.
Poor Regeneration	Regeneration solution is too harsh or too weak.	Screen a panel of regeneration solutions (low/high pH, high salt, detergents); use shorter contact times; if ligand is unstable, use a fresh surface for each cycle (not ideal).
Data Fits Poorly	Mass transport limitation; complex binding kinetics.	Increase flow rate; decrease ligand immobilization density; use a more complex binding model (e.g., two-state conformational change).

## Chapter 3: Bio-Layer Interferometry (BLI)

BLI is an optical, label-free technique that measures biomolecular interactions by analyzing changes in the interference pattern of white light reflected from the surface of a biosensor tip. [20][21] Its primary advantage is high throughput and compatibility with crude samples, as the dip-and-read format avoids microfluidics.[6][15]

### Principle of Operation

A BLI biosensor has two reflective surfaces: an internal reference layer and a biocompatible layer at the tip.[20] White light directed down the fiber reflects from both surfaces, creating an interference pattern. When the biosensor tip is dipped into a solution and a ligand is immobilized, the thickness of the biocompatible layer increases. Subsequently, when the tip is moved to a well containing an analyte that binds the ligand, the layer thickness increases further. This change in thickness causes a wavelength shift in the interference pattern, which is measured in real-time and is directly proportional to the number of bound molecules.[21]

Caption: The sequential "dip-and-read" workflow of a BLI experiment.

## Application Note: The Rationale for BLI

BLI is exceptionally well-suited for screening campaigns where hundreds or thousands of compounds must be rapidly assessed.[20][22] Its fluidics-free design simplifies operation and maintenance and increases tolerance to complex samples like cell lysates or supernatants. While generally less sensitive than SPR for very small molecules or fast kinetics, its high throughput makes it an ideal tool for hit identification and preliminary characterization.[9] It excels at rank-ordering compounds by affinity or off-rate and confirming binding before committing to more resource-intensive secondary assays.

## Detailed Protocol: BLI Analysis of a Protein-Small Molecule Interaction

This protocol assumes the use of streptavidin (SA) biosensors to capture a biotinylated protein.

### 1. Materials & Reagents:

- Biotinylated Protein (Ligand): >95% purity, at 5-25 µg/mL in a suitable buffer.[15]
- Small Molecule (Analyte): A dilution series in assay buffer.
- Assay Buffer: e.g., PBS with 0.02% Tween-20 and 0.1% BSA to prevent non-specific binding. [15]
- Biosensors: Streptavidin (SA) coated biosensors.
- Microplate: 96- or 384-well black microplate.

## 2. Experimental Procedure:

- Step 1: Plate Setup
  - Hydrate the SA biosensors in assay buffer for at least 10 minutes.
  - Fill the wells of the microplate with 200  $\mu$ L of the appropriate solutions: assay buffer for baseline and dissociation steps, biotinylated protein for the loading step, and the analyte dilution series for the association step.
- Step 2: Instrument Setup & Run
  - Define the assay steps in the instrument software:
    - Baseline 1: 60 seconds in assay buffer.
    - Loading: 120-300 seconds in the biotinylated protein solution.
    - Baseline 2: 60-120 seconds in assay buffer to wash away unbound protein and stabilize the signal.
    - Association: 120-300 seconds in the analyte dilution series.
    - Dissociation: 300-600 seconds in assay buffer.
  - Place the plate and biosensor tray in the instrument and start the run. The instrument will automatically move the biosensors between wells according to the defined protocol.[\[21\]](#)

## 3. Data Analysis:

- Data Processing: The software automatically performs reference subtraction (using a sensor with no analyte or a reference protein). Align the curves on the Y-axis at the beginning of the association or dissociation step.
- Model Fitting: Apply a global fit to the entire dataset using a 1:1 binding model to determine  $k_a$ ,  $k_d$ , and  $K_D$ . For screening, a steady-state analysis can be performed by plotting the response at equilibrium against analyte concentration.

## Troubleshooting Common BLI Issues

Issue	Potential Cause(s)	Recommended Solution(s)
High Signal Drift	Ligand leaching from the biosensor; buffer mismatch.	Ensure stable ligand capture (e.g., covalent coupling if biotin-streptavidin is weak); precisely match buffer components, especially DMSO, between analyte and baseline wells.[20]
Non-Specific Binding	Analyte binding to the biosensor surface itself.	Increase detergent (Tween-20) or BSA concentration in the assay buffer; use a reference sensor with an irrelevant immobilized protein to subtract non-specific effects.[20]
"Stepped" Association	Analyte is not fully soluble or is aggregating at high concentrations.	Visually inspect analyte solutions; filter samples; reduce the highest analyte concentration.

## Chapter 4: Isothermal Titration Calorimetry (ITC)

ITC stands apart from other techniques by directly measuring the heat released (exothermic) or absorbed (endothermic) during a binding event.[11][23] This allows for the direct, label-free determination of all thermodynamic binding parameters in a single experiment, making it the gold standard for thermodynamic characterization.[10]

### Principle of Operation

An ITC instrument consists of two identical cells: a reference cell (usually filled with water or buffer) and a sample cell containing the protein solution.[23] A syringe containing the small molecule ligand is used to perform a series of small, precise injections into the sample cell. As the ligand binds to the protein, heat is exchanged, causing a minute temperature difference between the sample and reference cells. The instrument's feedback system applies power to heaters to maintain zero temperature difference ( $\Delta T = 0$ ). The power required to do this is the

signal that is measured.[23] The first injections produce a large heat change as ample binding sites are available. As the protein becomes saturated, subsequent injections produce smaller heat changes, until only the heat of dilution is observed.[24][25]

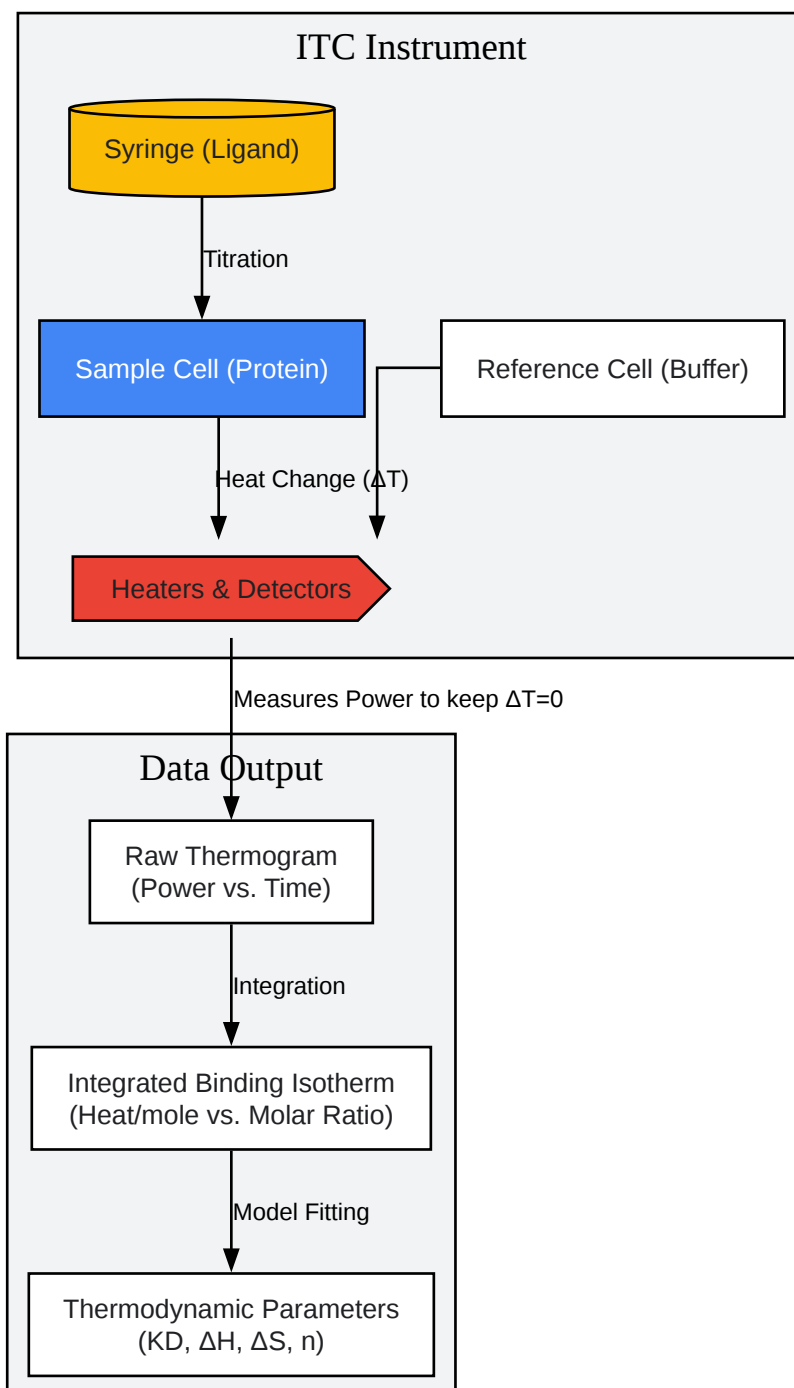

[Click to download full resolution via product page](#)

Caption: Schematic of an ITC experiment from titration to data output.

## Application Note: The Rationale for ITC

Choose ITC when the primary goal is to understand why an interaction occurs. The thermodynamic signature provides invaluable information for lead optimization. For instance:

- Enthalpy ( $\Delta H$ ): Reflects changes in heat from making and breaking bonds (e.g., hydrogen bonds, van der Waals forces). A favorable (negative)  $\Delta H$  suggests strong, specific bond formation.
- Entropy ( $\Delta S$ ): Reflects changes in the system's disorder, often driven by the release of ordered water molecules from binding surfaces (the hydrophobic effect). By dissecting the Gibbs free energy ( $\Delta G$ ) into its enthalpic and entropic components, researchers can rationally design molecules that optimize these driving forces to improve binding affinity and specificity.[\[10\]](#)

## Detailed Protocol: ITC Analysis of a Protein-Small Molecule Interaction

### 1. Materials & Reagents:

- Protein: >95% purity, at a concentration of 10-50  $\mu\text{M}$ .
- Small Molecule: At a concentration 10-20 times that of the protein.
- Buffer: Both protein and small molecule MUST be in an identical, well-dialyzed buffer to minimize heats of dilution.[\[24\]](#)

### 2. Experimental Procedure:

- Step 1: Sample Preparation
  - Dialysis: Extensively dialyze the protein against the final assay buffer. Reserve this exact same dialysis buffer (the dialysate) to dissolve the small molecule. This is the single most critical step for high-quality ITC data.

- Concentration Measurement: Accurately determine the concentrations of both protein and ligand post-preparation.[24]
- Degassing: Thoroughly degas both solutions immediately before the run to prevent bubbles in the cells.
- Step 2: Instrument Setup & Run
  - Carefully clean the sample cell and syringe.
  - Load the protein into the sample cell and the small molecule into the syringe.
  - Set the experimental parameters: cell temperature, stirring speed, number of injections (e.g., 19), and injection volume (e.g., 2  $\mu$ L).
  - Allow the system to equilibrate thermally before starting the titration.
- Step 3: Control Experiments
  - Perform a control experiment by titrating the ligand from the syringe into the buffer-filled sample cell.
  - This measures the heat of dilution of the ligand, which must be subtracted from the main experimental data for accurate analysis.

### 3. Data Analysis:

- Integrate the peaks from the raw thermogram to get the heat change for each injection.
- Subtract the heat of dilution from the control run.
- Plot the corrected heat per mole of injectant against the molar ratio of ligand to protein.
- Fit this binding isotherm to a suitable model (e.g., one-site binding) to determine  $K_{-}$  (and its inverse, the binding constant  $K_a$ ), the enthalpy  $\Delta H$ , and the stoichiometry  $n$ . [24]

## Chapter 5: Microscale Thermophoresis (MST)

MST is a technique that measures molecular interactions by detecting changes in the movement of molecules in a microscopic temperature gradient.[13][14] It is highly sensitive, consumes very little sample, and is performed in-solution in thin capillaries.[14][16]

## Principle of Operation

In MST, one binding partner is fluorescent (either intrinsically via tryptophan or via a fluorescent label).[7][26] A small volume of the sample is loaded into a capillary. An infrared laser creates a precise, microscopic temperature gradient.[7][13] Molecules move along this gradient, a phenomenon called thermophoresis. This movement is dependent on the molecule's size, charge, and hydration shell.[14] When a small molecule binds to the fluorescent protein, these properties change, altering its thermophoretic movement. This change in movement is detected as a change in the fluorescence distribution within the capillary and is used to quantify the binding affinity.

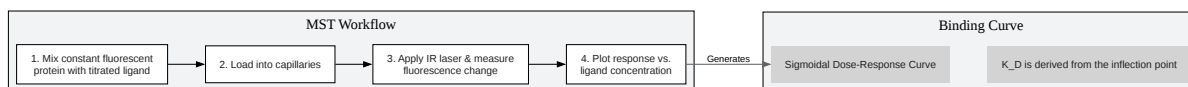

[Click to download full resolution via product page](#)

Caption: The straightforward workflow of an MST experiment.

## Application Note: The Rationale for MST

MST shines when sample quantity is limited or when surface immobilization is a concern. Its ability to perform measurements in just a few microliters of solution is a significant advantage.[16] Furthermore, because the measurement is performed in free solution, it is highly tolerant of complex buffers and even crude cell lysates, providing a more physiological context for the interaction.[12] This makes MST an excellent choice for validating hits from screens, studying challenging proteins that are difficult to immobilize, or when only precious material is available.

## Detailed Protocol: MST Analysis of a Protein-Small Molecule Interaction

### 1. Materials & Reagents:

- **Fluorescent Protein:** A constant, low nanomolar concentration of a fluorescently-labeled or tryptophan-containing protein.
- **Small Molecule (Ligand):** A 16-point, 2-fold serial dilution series starting at a concentration at least 20x higher than the expected  $K_d$ .
- **Assay Buffer:** A buffer that maintains protein stability and analyte solubility.
- **Capillaries:** Standard or premium capillaries as recommended by the instrument manufacturer.

### 2. Experimental Procedure:

- **Step 1: Sample Preparation**
  - Prepare the serial dilution of the small molecule ligand.
  - In separate tubes, mix each ligand dilution 1:1 with the fluorescent protein solution. Also prepare a "protein only" control.
  - Allow the mixtures to incubate for 5-10 minutes to reach binding equilibrium.
- **Step 2: Measurement**
  - Load ~10  $\mu$ L of each sample mixture into a separate MST capillary.
  - Place the capillaries in the instrument tray.
  - Start the measurement. The instrument will automatically apply the IR laser and record the fluorescence change for each capillary. A typical run for 16 capillaries takes about 10 minutes.[\[16\]](#)

### 3. Data Analysis:

- The software calculates the change in normalized fluorescence ( $\Delta F_{norm}$ ) for each ligand concentration.

- Plot  $\Delta F_{\text{norm}}$  against the logarithm of the ligand concentration.
- Fit the resulting sigmoidal curve to the K<sub>d</sub> model to determine the dissociation constant.

## Chapter 6: Integrated Workflows in Drug Discovery

In a modern drug discovery campaign, these label-free techniques are rarely used in isolation. They are most powerful when combined in a logical cascade to screen, validate, and characterize hits.

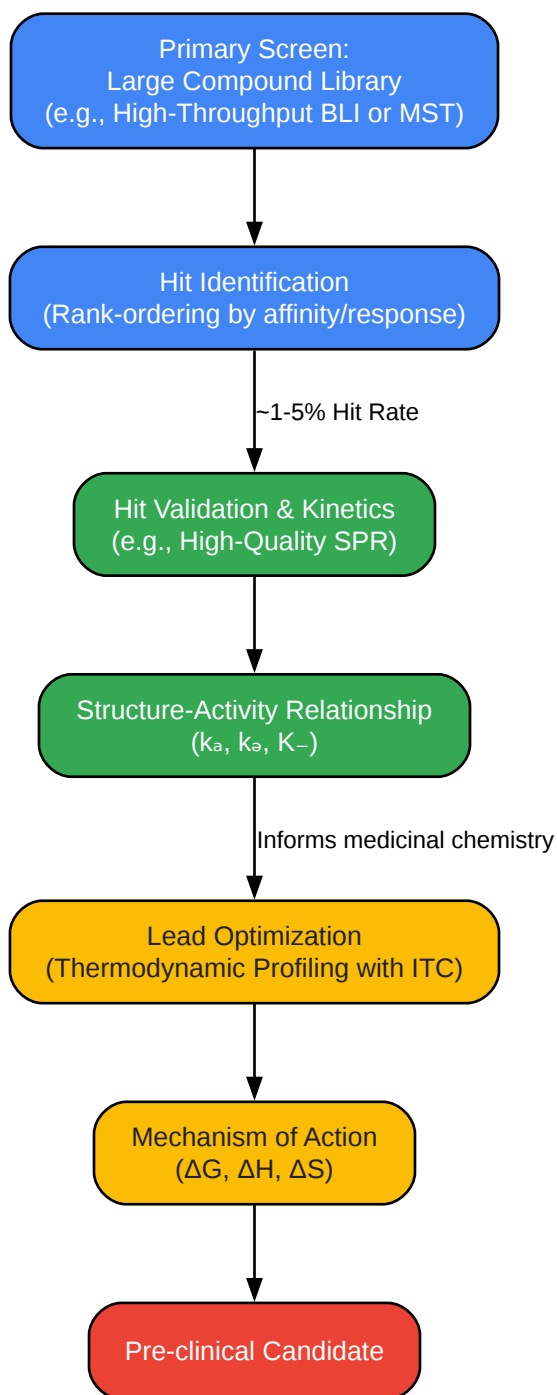

[Click to download full resolution via product page](#)

### Need Custom Synthesis?

BenchChem offers custom synthesis for rare earth carbides and specific isotopic labeling.

Email: [info@benchchem.com](mailto:info@benchchem.com) or [Request Quote Online](#).

## Sources

- [1. A Journey Without Labels: The Promise and Pitfalls of Label-Free Target Identification - PharmaFeatures \[pharmafeatures.com\]](#)
- [2. tandfonline.com \[tandfonline.com\]](#)
- [3. europeanpharmaceuticalreview.com \[europeanpharmaceuticalreview.com\]](#)
- [4. nicoyalife.com \[nicoyalife.com\]](#)
- [5. rapidnovor.com \[rapidnovor.com\]](#)
- [6. xantec.com \[xantec.com\]](#)
- [7. Comparison of Biomolecular Interaction Techniques — SPR vs ITC vs MST vs BLI \[reichertspr.com\]](#)
- [8. semanticscholar.org \[semanticscholar.org\]](#)
- [9. Label-free methods for optical in vitro characterization of protein–protein interactions - Physical Chemistry Chemical Physics \(RSC Publishing\) DOI:10.1039/D1CP01072G \[pubs.rsc.org\]](#)
- [10. researchgate.net \[researchgate.net\]](#)
- [11. atascientific.com.au \[atascientific.com.au\]](#)
- [12. Determining Binding Affinities Using MST | JoVE Journal \[jove.com\]](#)
- [13. bio-protocol.org \[bio-protocol.org\]](#)
- [14. nuvisan.com \[nuvisan.com\]](#)
- [15. ostr.ccr.cancer.gov \[ostr.ccr.cancer.gov\]](#)
- [16. MST Guidelines | Center for Structural Biology | Vanderbilt University \[vanderbilt.edu\]](#)
- [17. Principle and Protocol of Surface Plasmon Resonance \(SPR\) - Creative BioMart \[creativebiomart.net\]](#)
- [18. Characterization of Small Molecule–Protein Interactions Using SPR Method | Springer Nature Experiments \[experiments.springernature.com\]](#)
- [19. A surface plasmon resonance-based assay for small molecule inhibitors of human cyclophilin A - PMC \[pmc.ncbi.nlm.nih.gov\]](#)
- [20. biorxiv.org \[biorxiv.org\]](#)
- [21. protocols.io \[protocols.io\]](#)
- [22. Biolayer interferometry for DNA-protein interactions - PMC \[pmc.ncbi.nlm.nih.gov\]](#)

- [23. Isothermal Titration Calorimetry: A Biophysical Method to Characterize the Interaction between Label-free Biomolecules in Solution - PMC \[pmc.ncbi.nlm.nih.gov\]](#)
- [24. Isothermal Titration Calorimetry | Biomolecular Interactions Facility | The Huck Institutes \(en-US\) \[huck.psu.edu\]](#)
- [25. Isothermal Calorimetry: Molecular Interactions between Small Molecules in Organic Solvents | IntechOpen \[intechopen.com\]](#)
- [26. Use of Microscale Thermophoresis \(MST\) to Measure Binding Affinities of Components of the Fusion Machinery - PMC \[pmc.ncbi.nlm.nih.gov\]](#)
- To cite this document: BenchChem. [Application Note: Navigating the Landscape of Label-Free Interaction Analysis]. BenchChem, [2026]. [Online PDF]. Available at: [<https://www.benchchem.com/product/b1388940/docs#application-note-navigating-the-landscape-of-label-free-interaction-analysis>]

---

#### Disclaimer & Data Validity:

The information provided in this document is for Research Use Only (RUO) and is strictly not intended for diagnostic or therapeutic procedures. While BenchChem strives to provide accurate protocols, we make no warranties, express or implied, regarding the fitness of this product for every specific experimental setup.

**Technical Support:** The protocols provided are for reference purposes. Unsure if this reagent suits your experiment?

**Need Industrial/Bulk Grade?** [Request Custom Synthesis Quote](#)

## BenchChem

Our mission is to be the trusted global source of essential and advanced chemicals, empowering scientists and researchers to drive progress in science and industry.

#### Contact

Address: 3281 E Guasti Rd  
Ontario, CA 91761, United States  
Phone: (601) 213-4426  
Email: [info@benchchem.com](mailto:info@benchchem.com)

Contact our Ph.D. Support Team for a compatibility check