

Application Note: Regioselective C-H Functionalization of 2-Methoxy-4-methylthiophene

Author: BenchChem Technical Support Team. **Date:** May 2026

Compound of Interest

Compound Name: 2-Methoxy-4-methylthiophene

Cat. No.: B13871497

[Get Quote](#)

Executive Summary

This application note details field-proven methodologies for the direct functionalization of **2-Methoxy-4-methylthiophene**, a highly electron-rich and acid-sensitive heterocycle. Due to the synergistic directing effects of the C2-methoxy and C4-methyl groups, this scaffold exhibits a strong bias toward electrophilic substitution and C-H activation at the C5 position.

We present two validated protocols:

- Pd-Catalyzed Direct Arylation: Utilizing a Concerted Metallation-Deprotonation (CMD) pathway to install aryl groups at C5.
- Ir-Catalyzed C-H Borylation: A steric-controlled method to generate C5-pinacolboronate esters, essential intermediates for downstream Suzuki-Miyaura couplings.

Key Technical Insight: The presence of the C2-methoxy group (an enol ether equivalent) renders the substrate sensitive to strong Bronsted acids. Therefore, "Fagnou-type" conditions using pivalic acid (weak proton shuttle) are superior to Lewis-acid mediated pathways.

Substrate Analysis & Reactivity Profile[1]

To design effective protocols, one must first understand the electronic and steric landscape of the substrate.

Electronic and Steric Map[1]

- C2-Methoxy (-OMe): Strong electron-donating group (EDG) via resonance. Activates the ring but makes the C-O bond susceptible to hydrolysis under acidic conditions.
- C4-Methyl (-Me): Weak EDG. Provides steric bulk that shields the C3 position.
- C3 Position: Sterically "sandwiched" between the C2-OMe and C4-Me. Highly inaccessible to bulky catalysts.
- C5 Position: The "Goldilocks" zone. It is electronically activated (alpha to sulfur, para to methyl) and sterically accessible.

Reactivity Visualization

The following diagram illustrates the competing forces and the resultant regioselectivity.[1]

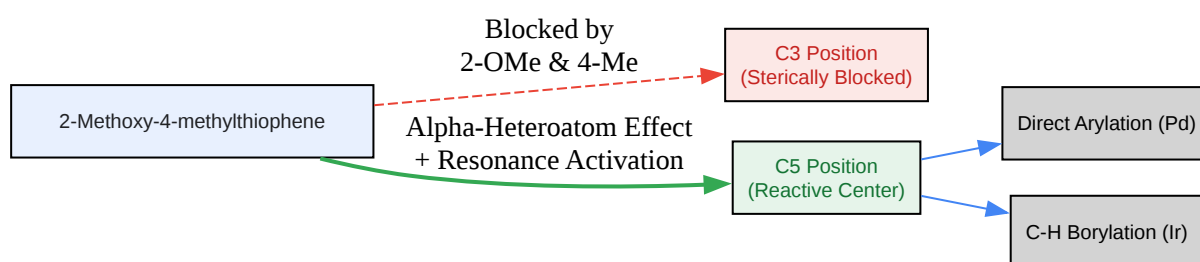

[Click to download full resolution via product page](#)

Figure 1: Reactivity map of **2-Methoxy-4-methylthiophene** showing the preferential activation at C5.

Protocol A: Pd-Catalyzed C5 Direct Arylation

Mechanism: Concerted Metallation-Deprotonation (CMD)

Direct arylation avoids the need for pre-functionalized organometallics (e.g., organotin in Stille coupling). For thiophenes, the CMD mechanism is operative.[2] A pivalate ligand on the Palladium acts as an intramolecular base, deprotonating the C5-H bond while the metal coordinates to the carbon.

Experimental Protocol (SOP)

Objective: Coupling of **2-Methoxy-4-methylthiophene** with 4-Bromobenzonitrile.

Reagents:

- Substrate: **2-Methoxy-4-methylthiophene** (1.0 equiv)
- Coupling Partner: 4-Bromobenzonitrile (1.2 equiv)
- Catalyst: Pd(OAc)₂ (5 mol%)[1]
- Ligand: PCy₃ HBF₄ (10 mol%) or SPhos (for difficult substrates)
- Base/Additive: K₂CO₃ (2.0 equiv) + Pivalic Acid (PivOH) (30 mol%)
- Solvent: Toluene or DMA (anhydrous)

Step-by-Step Procedure:

- Preparation: In a glovebox or under active Argon flow, charge a flame-dried Schlenk tube with Pd(OAc)₂ (11.2 mg, 0.05 mmol), PCy₃ HBF₄ (37 mg, 0.10 mmol), K₂CO₃ (276 mg, 2.0 mmol), and 4-Bromobenzonitrile (218 mg, 1.2 mmol).
- Substrate Addition: Add Pivalic Acid (30 mg, 0.3 mmol) followed by anhydrous Toluene (5 mL). Finally, add **2-Methoxy-4-methylthiophene** (128 mg, 1.0 mmol) via syringe.
- Reaction: Seal the tube and heat to 100°C for 16 hours. Vigorous stirring is essential as the base is heterogeneous.
- Workup: Cool to room temperature. Dilute with EtOAc (20 mL) and filter through a pad of Celite to remove inorganic salts.

- Purification: Concentrate the filtrate under reduced pressure. Purify via flash column chromatography (SiO₂, Hexanes/EtOAc gradient).

Critical Control Point: Do not omit Pivalic Acid. It lowers the energy barrier for C-H bond cleavage via the CMD transition state [1].

Protocol B: Ir-Catalyzed C-H Borylation

Steric Control Principle

Iridium-catalyzed borylation is governed almost entirely by sterics rather than electronics. The active catalyst, generated from [Ir(OMe)(COD)]₂ and dtbpy (4,4'-di-tert-butyl-2,2'-bipyridine), is bulky. It cannot access the C3 position due to the flanking substituents, resulting in exclusive C5 selectivity [2].

Experimental Protocol (SOP)

Objective: Synthesis of 2-(2-methoxy-4-methylthiophen-5-yl)-4,4,5,5-tetramethyl-1,3,2-dioxaborolane.

Reagents:

- Substrate: **2-Methoxy-4-methylthiophene** (1.0 equiv)
- Boron Source: B₂pin₂ (Bis(pinacolato)diboron) (0.6 equiv - Note: 1.2 equiv of B per dimer)
- Catalyst Precursor: [Ir(OMe)(COD)]₂ (1.5 mol%)
- Ligand: dtbpy (3.0 mol%)
- Solvent: n-Hexane or THF (anhydrous)

Step-by-Step Procedure:

- Catalyst Activation: In a glovebox, mix [Ir(OMe)(COD)]₂ (10 mg, 0.015 mmol) and dtbpy (8 mg, 0.03 mmol) in n-Hexane (2 mL). The solution should turn dark brown/red, indicating active catalyst formation.

- Reaction Assembly: Add B_2pin_2 (152 mg, 0.6 mmol) and **2-Methoxy-4-methylthiophene** (128 mg, 1.0 mmol) to the catalyst solution.
- Incubation: Seal the vial and heat to 60°C for 4-8 hours. (Note: Thiophenes are highly reactive; reaction may proceed at RT, but mild heating ensures completion).
- Monitoring: Monitor by GC-MS. Look for the disappearance of the starting material ($M^+ = 128$) and appearance of the boronate ester ($M^+ = 254$).
- Workup: Evaporate the solvent. The residue can often be used directly in Suzuki couplings. If purification is needed, pass quickly through a short plug of silica gel (eluting with CH_2Cl_2) or recrystallize from pentane. Avoid long exposure to silica as protodeboronation can occur.

Mechanistic & Troubleshooting Guide

The CMD Pathway (Palladium Cycle)

Understanding the catalytic cycle helps in troubleshooting low yields.

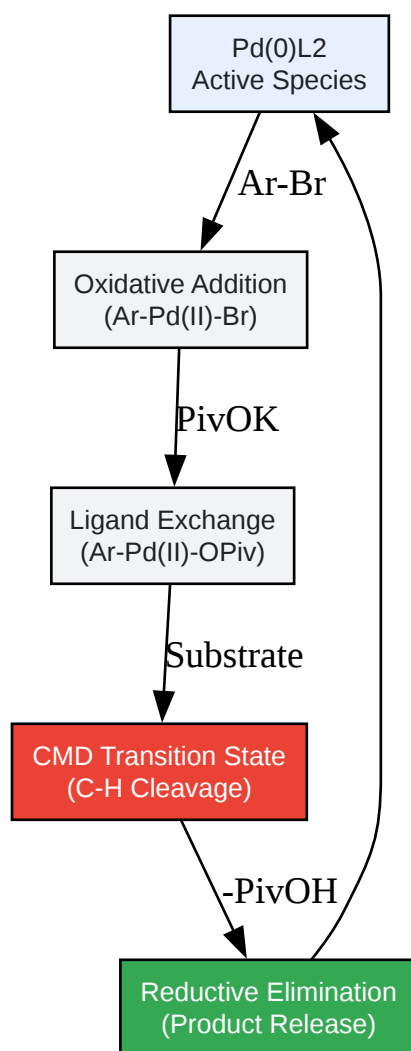

[Click to download full resolution via product page](#)

Figure 2: The Concerted Metallation-Deprotonation cycle. The Ligand Exchange step is where Pivalic Acid plays its critical role.

Troubleshooting Table

| Problem | Probable Cause | Solution |
|-----------------------|------------------------------|--|
| Low Yield (Arylation) | Catalyst poisoning by Sulfur | Switch to SPhos or XPhos ligands; increase catalyst loading to 5-10 mol%. |
| Hydrolysis of -OMe | Acidic conditions | Ensure K ₂ CO ₃ is dry; strictly avoid strong acids; ensure PivOH concentration is <30 mol%. |
| C3-Arylation (Trace) | High Temperature | Reduce temperature to 80°C. The C5 position is kinetically favored; high T can erode selectivity. |
| Protodeboronation | Moisture/Silica Acidity | Store boronate esters in the freezer; use neutral alumina instead of silica for purification. |

References

- Lapointe, D., & Fagnou, K. (2010). Overview of the Concerted Metallation-Deprotonation Mechanism in Palladium-Catalyzed C-H Activation. *Chemistry Letters*. Source:
- Larsen, M. A., & Hartwig, J. F. (2014).[3] Iridium-Catalyzed C-H Borylation of Heteroarenes: Scope, Regioselectivity, and Mechanism. *Journal of the American Chemical Society*.[3] Source:
- Mondal, A., & van Gemmeren, M. (2020).[4] Catalyst-Controlled Regiodivergent C-H Alkynylation of Thiophenes. *Angewandte Chemie International Edition*. Source:
- Doucet, H. (2016). Regioselective C-H Functionalization of the Six-Membered Ring of the 6,5-Fused Heterocyclic Systems. *MDPI*. Source:

Need Custom Synthesis?

BenchChem offers custom synthesis for rare earth carbides and specific isotopic labeling.

Email: info@benchchem.com or [Request Quote Online](#).

Sources

- [1. mdpi.com \[mdpi.com\]](https://www.mdpi.com)
- [2. iris.unimore.it \[iris.unimore.it\]](https://iris.unimore.it)
- [3. escholarship.org \[escholarship.org\]](https://escholarship.org)
- [4. Catalyst-Controlled Regiodivergent C-H Alkynylation of Thiophenes* - PubMed \[pubmed.ncbi.nlm.nih.gov\]](#)
- To cite this document: BenchChem. [Application Note: Regioselective C-H Functionalization of 2-Methoxy-4-methylthiophene]. BenchChem, [2026]. [Online PDF]. Available at: [\[https://www.benchchem.com/product/b13871497/docs#application-note-regioselective-c-h-functionalization-of-2-methoxy-4-methylthiophene\]](https://www.benchchem.com/product/b13871497/docs#application-note-regioselective-c-h-functionalization-of-2-methoxy-4-methylthiophene)

Disclaimer & Data Validity:

The information provided in this document is for Research Use Only (RUO) and is strictly not intended for diagnostic or therapeutic procedures. While BenchChem strives to provide accurate protocols, we make no warranties, express or implied, regarding the fitness of this product for every specific experimental setup.

Technical Support: The protocols provided are for reference purposes. Unsure if this reagent suits your experiment?

Need Industrial/Bulk Grade? [Request Custom Synthesis Quote](#)

BenchChem

Our mission is to be the trusted global source of essential and advanced chemicals, empowering scientists and researchers to drive progress in science and industry.

Contact

Address: 3281 E Guasti Rd
Ontario, CA 91761, United States
Phone: (601) 213-4426
Email: info@benchchem.com

Contact our Ph.D. Support Team for a compatibility check