

Application Note: Pyrazole Scaffolds in Medicinal Chemistry

Author: BenchChem Technical Support Team. **Date:** May 2026

Compound of Interest

Compound Name: (1-Methyl-1H-pyrazol-5-yl)methanamine hydrochloride

CAS No.: 1185169-37-2

Cat. No.: B1387863

[Get Quote](#)

Executive Summary

The pyrazole ring (1,2-diazole) is a "privileged scaffold" in modern drug discovery, appearing in over 30 FDA-approved therapeutics including Celecoxib, Ruxolitinib, and Sildenafil. Its ubiquity stems from its unique physicochemical properties: it serves as a robust bioisostere for phenols and imidazoles, functions as a high-fidelity ATP mimetic in kinase inhibitors, and offers tunable lipophilicity (LogP) and metabolic stability.

This guide provides a technical roadmap for leveraging pyrazole chemistry in drug design. It covers the structural logic of pyrazole-protein interactions, detailed protocols for regioselective synthesis, and strategies for optimizing pharmacokinetic (PK) profiles.

Structural Logic: Why Pyrazoles?

The Bioisosteric Advantage

In medicinal chemistry, the pyrazole ring is frequently deployed to replace metabolically labile or toxic moieties without sacrificing binding affinity.[1]

- **Phenol Mimicry:** The N-H of a pyrazole can act as a hydrogen bond donor (HBD) similar to a phenolic hydroxyl, but without the metabolic liability of glucuronidation or the toxicity associated with quinone methide formation.
- **Adenine Mimicry (Kinase Inhibition):** The N1-N2 motif perfectly emulates the N1-C6-N7 hydrogen-bonding pattern of the adenine purine ring, allowing pyrazoles to anchor into the ATP-binding hinge region of kinases.

Physicochemical Tuning[1][2]

- **Acidity/Basicity:** Unsubstituted pyrazole has a pKa of ~2.5 (conjugate acid) and ~14.2 (N-H acidity). This amphoteric nature allows for modulation of solubility via salt formation.
- **Tautomerism:** The annular tautomerism (1H- vs. 2H-pyrazole) is critical.[1] In solution, the equilibrium shifts based on solvent polarity and substituents. Critical Design Note: When docking pyrazoles, always simulate both tautomers; a "inactive" compound in silico may simply be modeled in the wrong tautomeric state for the binding pocket.

Application I: Kinase Inhibitor Design

Case Study: Ruxolitinib (JAK1/2 Inhibitor)

Mechanism of Action

Pyrazoles are ATP-competitive inhibitors. They occupy the adenine binding pocket, forming hydrogen bonds with the "hinge region" backbone residues.

- **H-Bond Acceptor (N2):** Interacts with the backbone NH of the hinge residue.
- **H-Bond Donor (N1-H):** Interacts with the backbone Carbonyl of the hinge residue.

SAR Logic & Optimization

To convert a raw pyrazole hit into a lead candidate, follow this optimization logic:

- **Core Anchoring:** Establish the H-bond network with the hinge region.

- Gatekeeper Interaction: Substitute the C3/C5 positions to access the hydrophobic "gatekeeper" pocket. Bulky groups here can improve selectivity (e.g., T790M mutant targeting in EGFR).
- Solubility Tail: Append solubilizing groups (morpholine, piperazine) at the solvent-exposed front (N1 or C4 position).

Visualization: Kinase Inhibitor Pharmacophore

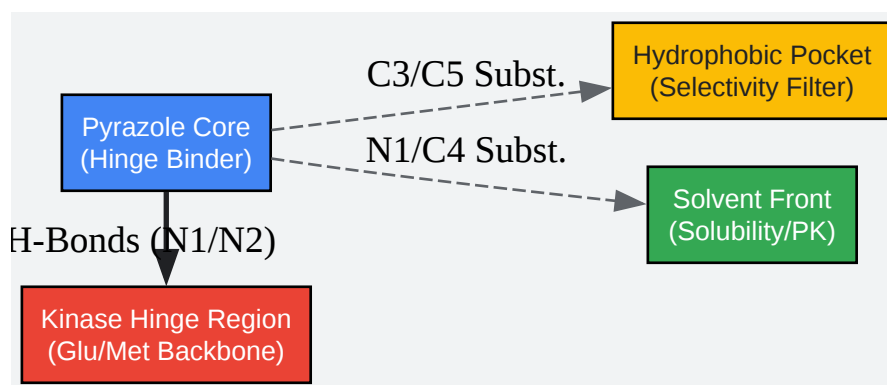

[Click to download full resolution via product page](#)

Figure 1: Pharmacophore mapping of pyrazole-based kinase inhibitors. The core anchors to the hinge, while substituents tune selectivity and solubility.

Application II: Anti-Inflammatory (COX-2 Selectivity)

Case Study: Celecoxib^{[1][2][3][4][5]}

The Selectivity Switch

Non-steroidal anti-inflammatory drugs (NSAIDs) traditionally inhibit both COX-1 (gastroprotective) and COX-2 (inflammatory). Celecoxib achieves COX-2 selectivity via a specific structural feature:

- The Side Pocket: COX-2 has a hydrophilic side pocket (Arg120/Val523) that is inaccessible in COX-1 (due to Isoleucine 523).
- The Pyrazole Role: The rigid pyrazole scaffold orients a polar sulfonamide group directly into this side pocket, locking the inhibitor into COX-2 while sterically clashing with COX-1.

Experimental Protocol: Regioselective Synthesis

The most common synthetic challenge is regioselectivity. The reaction of hydrazine with an unsymmetrical 1,3-diketone typically yields a mixture of regioisomers (1,3- vs 1,5-substituted).

Protocol: Regioselective Synthesis of 1,3,5-Trisubstituted Pyrazoles

Objective: Synthesize a Celecoxib analog with >95:5 regioselectivity.

Materials

- Substrate: 4,4,4-Trifluoro-1-(4-methylphenyl)butane-1,3-dione (1.0 eq)
- Reagent: 4-Sulfonamidophenylhydrazine hydrochloride (1.1 eq)
- Solvent System: Ethanol / Trifluoroacetic Acid (TFA) or Fluorinated Alcohols (TFE).
- Catalyst: TFA (promotes 1,3-isomer formation).

Step-by-Step Methodology

- Preparation:
 - Dissolve 10 mmol of the 1,3-diketone in 20 mL of Ethanol (EtOH).
 - Add 11 mmol of the hydrazine salt.
- Regiocontrol Step (CRITICAL):
 - For 1,3-isomer (Celecoxib-like): Add 10 mol% TFA. The acid activates the carbonyl adjacent to the CF₃ group, directing the initial nucleophilic attack of the hydrazine terminal nitrogen.
 - For 1,5-isomer: Use basic conditions (Et₃N) to deprotonate the hydrazine, altering the nucleophilicity profile.
- Reflux:

- Heat the mixture to reflux (78°C) for 4–6 hours. Monitor by TLC (Mobile phase: 30% EtOAc/Hexanes).
- Workup:
 - Cool to room temperature.[5]
 - The product often precipitates. Filter and wash with cold EtOH.
 - If no precipitate: Evaporate solvent, redissolve in EtOAc, wash with NaHCO₃ (sat), then Brine.
- Purification:
 - Recrystallize from EtOH/Water (9:1) to remove trace regioisomers.
 - QC Check: ¹H-NMR is required to distinguish isomers. Look for the pyrazole C4-H singlet. In 1,3-isomers (CF₃ at C3), the C4-H often shifts upfield relative to the 1,5-isomer.

Visualization: Synthetic Decision Tree

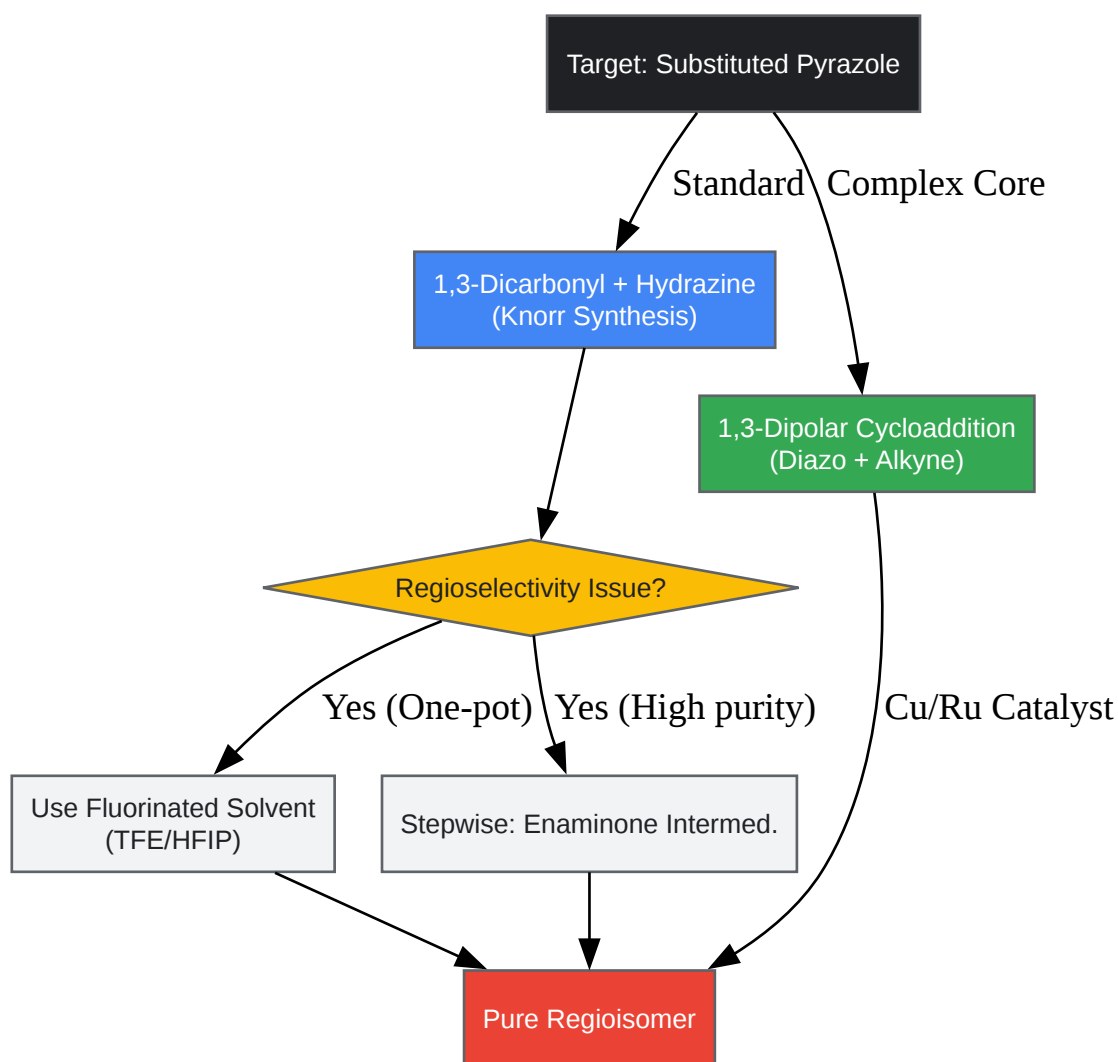

[Click to download full resolution via product page](#)

Figure 2: Decision tree for selecting the appropriate synthetic route based on regioselectivity requirements.

Data Summary: Pyrazole Drug Classes

Drug Name	Target	Indication	Key Pyrazole Function
Celecoxib	COX-2	Inflammation/Pain	Orients sulfonamide into selectivity pocket.
Ruxolitinib	JAK1/2	Myelofibrosis	Adenine mimic (hinge binding).
Sildenafil	PDE5	Erectile Dysfunction	Mimics guanine base of cGMP.
Crizotinib	ALK/ROS1	NSCLC (Cancer)	Hinge binder; scaffolds lipophilic groups.
Rimonabant	CB1	Obesity (Withdrawn)	Central scaffold for receptor antagonism.

References

- Recent Highlights in the Synthesis and Biological Significance of Pyrazole Derivatives (2024). Heliyon. [\[Link\]](#)
- The Importance of the Pyrazole Scaffold in the Design of Protein Kinases Inhibitors (2023). International Journal of Molecular Sciences. [\[Link\]](#)
- Regioselective Synthesis of Polysubstituted Pyrazoles. Journal of Organic Chemistry. [\[Link\]](#)
- Celecoxib Synthesis and Process Development. Organic Process Research & Development. [\[Link\]](#)[4]
- Pyrazole-containing pharmaceuticals: target, pharmacological activity, and SAR. RSC Medicinal Chemistry. [\[Link\]](#)

Need Custom Synthesis?

BenchChem offers custom synthesis for rare earth carbides and specific isotopic labeling.

Email: info@benchchem.com or [Request Quote Online](#).

Sources

- [1. Pyrazole-containing pharmaceuticals: target, pharmacological activity, and their SAR studies - PMC \[pmc.ncbi.nlm.nih.gov\]](#)
- [2. Synthesis and Characterization of Celecoxib Derivatives as Possible Anti-Inflammatory, Analgesic, Antioxidant, Anticancer and Anti-HCV Agents - PMC \[pmc.ncbi.nlm.nih.gov\]](#)
- [3. Continuous flow synthesis of Celecoxib from 2-bromo-3,3,3-trifluoropropene - PMC \[pmc.ncbi.nlm.nih.gov\]](#)
- [4. researchgate.net \[researchgate.net\]](#)
- [5. pdf.benchchem.com \[pdf.benchchem.com\]](#)
- To cite this document: BenchChem. [Application Note: Pyrazole Scaffolds in Medicinal Chemistry]. BenchChem, [2026]. [Online PDF]. Available at: [\[https://www.benchchem.com/product/b1387863/docs#application-note-pyrazole-scaffolds-in-medicinal-chemistry\]](https://www.benchchem.com/product/b1387863/docs#application-note-pyrazole-scaffolds-in-medicinal-chemistry)

Disclaimer & Data Validity:

The information provided in this document is for Research Use Only (RUO) and is strictly not intended for diagnostic or therapeutic procedures. While BenchChem strives to provide accurate protocols, we make no warranties, express or implied, regarding the fitness of this product for every specific experimental setup.

Technical Support: The protocols provided are for reference purposes. Unsure if this reagent suits your experiment?

Need Industrial/Bulk Grade? [Request Custom Synthesis Quote](#)

BenchChem

Our mission is to be the trusted global source of essential and advanced chemicals, empowering scientists and researchers to drive progress in science and industry.

Contact

Address: 3281 E Guasti Rd
Ontario, CA 91761, United States
Phone: (601) 213-4426
Email: info@benchchem.com

Contact our Ph.D. Support Team for a compatibility check