

Development of a validated assay for Amitriptyline N-beta-D-Glucuronide

Author: BenchChem Technical Support Team. **Date:** April 2026

Compound of Interest

Compound Name: *Amitriptyline N-beta-D-Glucuronide*
Cat. No.: *B13864041*

[Get Quote](#)

Validated Assay Development for Amitriptyline N-β-D-Glucuronide

Application Note & Protocol Guide

Part 1: Executive Summary & Scientific Rationale

The Analytical Challenge

Amitriptyline N-β-D-Glucuronide (AT-N-Glu) represents a distinct class of Phase II metabolites: Quaternary Ammonium Glucuronides. Unlike the more common O-glucuronides or acid-labile N-glucuronides of aromatic amines, AT-N-Glu is formed via the conjugation of a tertiary aliphatic amine (Amitriptyline) by UGT1A4 and UGT2B10.

This creates a permanent positive charge on the nitrogen atom, rendering the molecule highly polar and chemically distinct. While chemically more stable against acid hydrolysis than acyl glucuronides, the primary bioanalytical risk is In-Source Fragmentation (ISF).

The "False Positive" Trap: In the electrospray ionization (ESI) source, the labile glycosidic bond of AT-N-Glu can rupture before the first quadrupole (Q1). This releases the aglycone (Amitriptyline,

278). If the metabolite is not chromatographically separated from the parent drug, the fragmented metabolite will be detected in the parent drug's MRM channel, leading to a gross overestimation of Amitriptyline levels.

Metabolic Context

Understanding the biological origin is crucial for interpreting pharmacokinetic data.

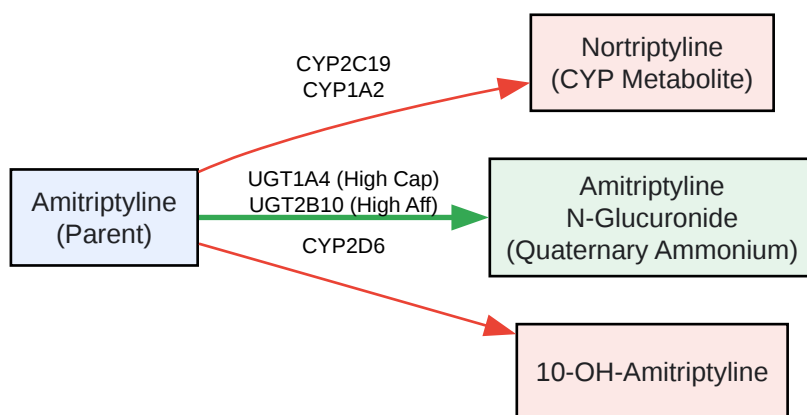

[Click to download full resolution via product page](#)

Figure 1: Metabolic pathway of Amitriptyline highlighting the direct N-glucuronidation pathway mediated by UGT1A4 and UGT2B10.

Part 2: Method Development Strategy

Mass Spectrometry Optimization

Unlike typical analytes requiring protonation

, AT-N-Glu is a pre-charged cation

.

- Polarity: Positive ESI.
- Precursor Ion:

454.2 (Note: MW is ~453.5. The cation is the M+ species).

- Product Ions:
 - Quantifier:
278.2 (Loss of glucuronic acid moiety, -176 Da).
 - Qualifier:
233.1 (Further fragmentation of the tricyclic ring system).
- Source Temperature: Keep moderate (350°C - 450°C). Excessively high temperatures increase In-Source Fragmentation.

Chromatographic Separation (Critical)

You must achieve baseline separation between Amitriptyline (Parent) and AT-N-Glu.

- Column: C18 or Phenyl-Hexyl phases are recommended.
- Elution Order: AT-N-Glu is significantly more polar and will elute earlier than Amitriptyline on Reverse Phase.
- Mobile Phase: Acidic pH (0.1% Formic Acid) is required to maintain peak shape for the parent (tertiary amine), but it does not affect the charge state of the quaternary glucuronide.

Sample Preparation

While AT-N-Glu is resistant to acid hydrolysis (unlike acyl glucuronides), it is thermally labile.

- Recommended: Protein Precipitation (PPT) with cold Acetonitrile.
- Alternative: Solid Phase Extraction (SPE) using weak cation exchange (WCX) if sensitivity is an issue, though PPT is usually sufficient for plasma levels > 1 ng/mL.

Part 3: Detailed Experimental Protocol

A. Reagents & Materials[1][2]

- Reference Standard: Amitriptyline N-β-D-Glucuronide (purity >98%).
- Internal Standard (IS): Amitriptyline-d3 N-Glucuronide (preferred) or Amitriptyline-d3.
- Matrix: Human Plasma (K2EDTA).
- Solvents: LC-MS grade Methanol, Acetonitrile, Formic Acid, Ammonium Formate.

B. Sample Preparation (Protein Precipitation)

Rationale: Simple, rapid, and minimizes pH shifts that could induce degradation.

- Aliquot: Transfer 50 μL of plasma into a 1.5 mL polypropylene tube or 96-well plate.
- IS Addition: Add 20 μL of Internal Standard working solution (50 ng/mL in 50:50 MeOH:H₂O).
- Precipitation: Add 200 μL of ice-cold Acetonitrile containing 0.1% Formic Acid.
 - Note: The slight acid helps precipitate proteins and solubilize the parent drug.
- Vortex: Mix vigorously for 2 minutes.
- Centrifugation: Spin at 4,000 x g for 10 minutes at 4°C.
- Dilution: Transfer 100 μL of the supernatant to a clean plate. Add 100 μL of Water (0.1% Formic Acid).
 - Why? Injecting pure acetonitrile causes peak fronting for early eluting polar compounds like glucuronides. This dilution matches the solvent strength to the initial mobile phase.

C. LC-MS/MS Conditions[1][3][4]

Parameter	Setting
System	UHPLC coupled to Triple Quadrupole MS
Column	Waters XSelect CSH C18 (2.1 x 100 mm, 2.5 μ m) or equivalent
Mobile Phase A	5 mM Ammonium Formate + 0.1% Formic Acid in Water
Mobile Phase B	Acetonitrile + 0.1% Formic Acid
Flow Rate	0.4 mL/min
Column Temp	40°C
Injection Vol	5 μ L

Gradient Profile:

- 0.0 - 1.0 min: 5% B (Focus the glucuronide)
- 1.0 - 4.0 min: Linear ramp to 95% B (Elute parent)
- 4.0 - 5.0 min: Hold 95% B (Wash)
- 5.0 - 5.1 min: Return to 5% B
- 5.1 - 7.0 min: Re-equilibration

D. Analytical Workflow Diagram

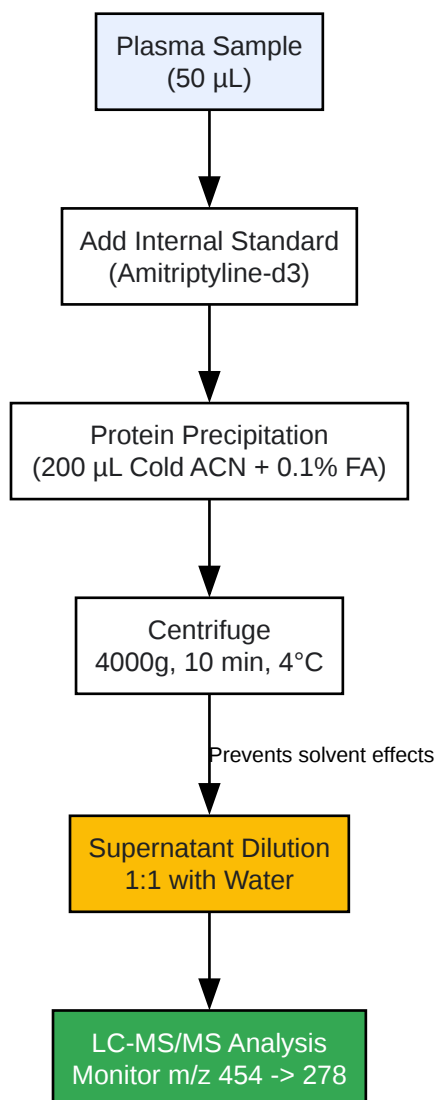

[Click to download full resolution via product page](#)

Figure 2: Step-by-step bioanalytical workflow ensuring glucuronide stability and chromatographic integrity.

Part 4: Validation & Troubleshooting

The "ISF" Check (Mandatory)

During method validation, you must prove that the peak in the Amitriptyline channel is not an artifact of the Glucuronide.

- Experiment: Inject a high concentration pure standard of only AT-N-Glucuronide (e.g., 1000 ng/mL).

- Monitor: Both the Glucuronide transition (454->278) and the Parent transition (278->233).
- Acceptance Criteria: You will likely see a peak in the 278->233 channel at the retention time of the Glucuronide. This is the In-Source Fragment.
- Crucial Validation: Ensure this artifact peak is completely resolved ($R_s > 1.5$) from the actual Amitriptyline parent peak retention time.

Stability Assessment

Although quaternary ammonium glucuronides are more stable than acyl glucuronides, they are not inert.

- Freeze-Thaw: Validate for 3 cycles at -80°C .
- Benchtop: Keep samples on ice/CoolRack during processing.
- Back-Conversion: Test QC samples containing only the Glucuronide. Analyze them for the presence of Parent drug after processing. If Parent drug levels increase $>15\%$ of the theoretical Glucuronide input (molar equivalent), your processing method is causing hydrolysis (likely thermal).

Matrix Effects

Quaternary ammoniums can suffer from severe ion suppression due to phospholipids.

- Monitoring: Monitor phospholipid transitions (m/z 184 -> 184) during development.
- Mitigation: If suppression is high at the Glucuronide retention time (usually early eluting), switch to a Phenyl-Hexyl column to shift the selectivity away from the phospholipid breakthrough.

References

- FDA Guidance for Industry. (2018). Bioanalytical Method Validation. U.S. Department of Health and Human Services.[1][2] [Link](#)

- Zhou, D., et al. (2010).[3] "Role of Human UGT2B10 in N-Glucuronidation of Tricyclic Antidepressants, Amitriptyline, Imipramine, Clomipramine, and Trimipramine." *Drug Metabolism and Disposition*, 38(5), 863–870. [Link](#)
- Lehman, J. P., Fenselau, C., & DePaulo, J. R. (1983). "Quaternary ammonium-linked glucuronides of amitriptyline, imipramine, and chlorpromazine." [4] *Drug Metabolism and Disposition*, 11(3), 221-225. [Link](#)
- Breyer-Pfaff, U., et al. (1997).[5] "Biphasic kinetics of quaternary ammonium glucuronide formation from amitriptyline and diphenhydramine in human liver microsomes." *Drug Metabolism and Disposition*, 25(3), 340-345. [Link](#)

Need Custom Synthesis?

BenchChem offers custom synthesis for rare earth carbides and specific isotopic labeling.

Email: info@benchchem.com or [Request Quote Online](#).

Sources

- [1. fda.gov \[fda.gov\]](https://www.fda.gov)
- [2. ClinPGx \[clinpgx.org\]](https://www.clinpgx.org)
- [3. Role of human UGT2B10 in N-glucuronidation of tricyclic antidepressants, amitriptyline, imipramine, clomipramine, and trimipramine - PubMed \[pubmed.ncbi.nlm.nih.gov\]](https://pubmed.ncbi.nlm.nih.gov)
- [4. pure.johnshopkins.edu \[pure.johnshopkins.edu\]](https://pure.johnshopkins.edu)
- [5. Redirecting \[linkinghub.elsevier.com\]](https://linkinghub.elsevier.com)
- To cite this document: BenchChem. [Development of a validated assay for Amitriptyline N-beta-D-Glucuronide]. BenchChem, [2026]. [Online PDF]. Available at: [\[https://www.benchchem.com/product/b13864041/docs#development-of-a-validated-assay-for-amitriptyline-n-beta-d-glucuronide\]](https://www.benchchem.com/product/b13864041/docs#development-of-a-validated-assay-for-amitriptyline-n-beta-d-glucuronide)

Disclaimer & Data Validity:

The information provided in this document is for Research Use Only (RUO) and is strictly not intended for diagnostic or therapeutic procedures. While BenchChem strives to provide

accurate protocols, we make no warranties, express or implied, regarding the fitness of this product for every specific experimental setup.

Technical Support: The protocols provided are for reference purposes. Unsure if this reagent suits your experiment?

Need Industrial/Bulk Grade? [Request Custom Synthesis Quote](#)

BenchChem

Our mission is to be the trusted global source of essential and advanced chemicals, empowering scientists and researchers to drive progress in science and industry.

Contact

Address: 3281 E Guasti Rd

Ontario, CA 91761, United States

Phone: (601) 213-4426

Email: info@benchchem.com

[Contact our Ph.D. Support Team for a compatibility check](#)