

# Application Note: High-Efficiency Reductive Amination of 2-Methoxy-6-Quinolinecarboxaldehyde

**Author:** BenchChem Technical Support Team. **Date:** May 2026

## Compound of Interest

Compound Name: 2-methoxy-6-  
Quinolinecarboxaldehyde

Cat. No.: B13861889

[Get Quote](#)

## Abstract & Scope

This technical guide details the optimized protocol for the reductive amination of **2-methoxy-6-quinolinecarboxaldehyde** to synthesize functionalized (2-methoxyquinolin-6-yl)methylamines. This scaffold is a critical pharmacophore in medicinal chemistry, particularly in the development of novel antibacterial (Type II Topoisomerase inhibitors) and antimalarial agents.

Unlike standard benzenoid aldehydes, the quinoline core introduces specific electronic constraints—most notably the inductive electron-withdrawal of the nitrogen heterocycle combined with the resonance donation of the 2-methoxy group. This protocol prioritizes Sodium Triacetoxyborohydride (STAB) in 1,2-dichloroethane (DCE) to ensure chemoselectivity, preventing the reduction of the aldehyde to the alcohol prior to imine formation, while maintaining the integrity of the acid-labile 2-methoxy ether.

## Scientific Foundation & Reactivity Profile

### Electronic Context

The substrate, **2-methoxy-6-quinolinecarboxaldehyde**, presents a unique reactivity profile:

- **6-Position Aldehyde:** Located on the benzenoid ring, it is electronically coupled to the pyridine ring. The electron-deficient nature of the quinoline ring makes the carbonyl carbon highly electrophilic, facilitating rapid imine formation.
- **2-Methoxy Group:** This group acts as a masked quinolone. While stable under basic and neutral conditions, it is susceptible to hydrolysis under strong acidic conditions (pH < 1) or high temperatures, which would yield the thermodynamically stable 2-quinolone (carbostyryl). Therefore, mildly acidic conditions (Acetic Acid, pH 5-6) are strictly required.

## Reagent Selection Strategy

Reagent	Suitability	Rationale
NaBH(OAc) <sub>3</sub> (STAB)	Optimal	Mild hydride donor. Reacts rapidly with imines/iminiums but negligibly with aldehydes. Allows "One-Pot" protocol without pre-forming the imine. [1]
NaBH <sub>3</sub> CN	Sub-optimal	Effective but highly toxic (HCN risk). Requires lower pH which risks methoxy hydrolysis. Harder to work up.
NaBH <sub>4</sub>	Poor	Too reactive. Reduces the aldehyde to the alcohol (competitive side reaction) faster than imine reduction in one-pot setups.
H <sub>2</sub> / Pd-C	Conditional	Good for simple amines, but risks reducing the quinoline ring (heterocyclic hydrogenation) or hydrogenolysis of the benzylic C-N bond.

## Reaction Mechanism

The reaction proceeds via a stepwise condensation-reduction pathway. The presence of Acetic Acid (AcOH) protonates the carbinolamine intermediate, facilitating water elimination to form the electrophilic iminium ion, which is then irreversibly reduced by the hydride.

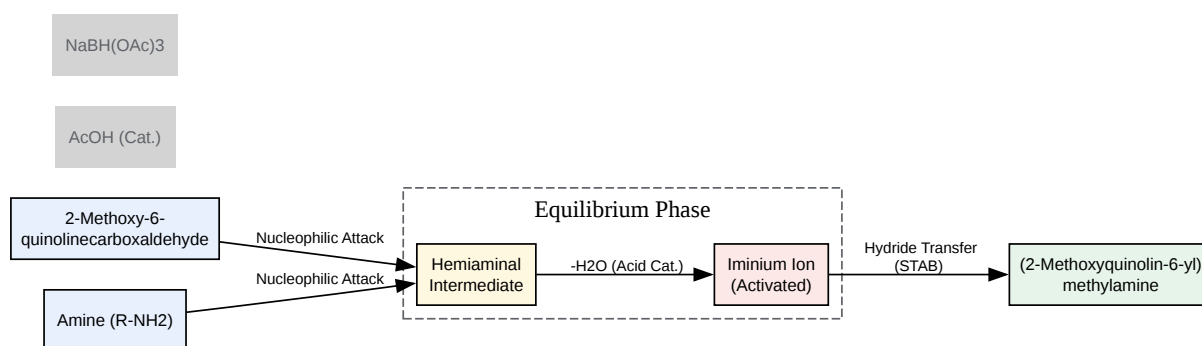

[Click to download full resolution via product page](#)

Figure 1: Mechanistic pathway of STAB-mediated reductive amination.

## Experimental Protocol

### Materials

- Substrate: **2-methoxy-6-quinolinecarboxaldehyde** (1.0 equiv)
- Amine: Primary or Secondary Amine (1.1 – 1.2 equiv)
- Reductant: Sodium Triacetoxyborohydride (STAB) (1.4 – 1.5 equiv)
- Solvent: 1,2-Dichloroethane (DCE) (anhydrous preferred)
- Catalyst: Glacial Acetic Acid (1.0 equiv)
- Quench: Sat. NaHCO<sub>3</sub> solution

## Step-by-Step Procedure

### Step 1: Solvation & Imine Formation

- Charge a flame-dried reaction vial with **2-methoxy-6-quinolinecarboxaldehyde** (1.0 mmol, 187 mg).
- Add DCE (5 mL, 0.2 M concentration). Note: DCM can be used if DCE is restricted, but DCE allows for slightly higher temperatures if the imine formation is sluggish.
- Add the Amine (1.1 mmol).
- Add Glacial Acetic Acid (1.0 mmol, 60  $\mu$ L).
- Stir at Room Temperature (RT) for 30–60 minutes under Nitrogen.
  - Checkpoint: Monitor by TLC or LCMS. While STAB allows one-pot addition, a short pre-stir ensures the equilibrium shifts toward the imine, minimizing aldehyde reduction.

Step 2: Reduction 6. Add Sodium Triacetoxyborohydride (STAB) (1.5 mmol, 318 mg) in a single portion.

- Observation: Mild effervescence may occur.
- Stir at RT for 2–16 hours.
- Validation: Reaction is complete when the starting aldehyde is consumed (<5% by HPLC).

Step 3: Workup & Isolation 8. Quench: Slowly add saturated aqueous  $\text{NaHCO}_3$  (5 mL) to the reaction mixture. Stir vigorously for 15 minutes to neutralize the acetic acid and decompose excess borohydride. 9. Extraction: Dilute with DCM (10 mL). Separate the organic layer.<sup>[2]</sup> Extract the aqueous layer once more with DCM (10 mL). 10. Drying: Combine organic phases, dry over anhydrous  $\text{Na}_2\text{SO}_4$ , filter, and concentrate in vacuo. 11. Purification: The crude material is often clean enough for use (purity >90%). If necessary, purify via flash chromatography ( $\text{SiO}_2$ ) using a gradient of DCM/MeOH (95:5 to 90:10).

## Critical Parameters & Troubleshooting

Issue	Probable Cause	Corrective Action
Low Yield / Aldehyde Recovery	Imine formation failed before reduction.	Increase pre-stir time (Step 1) to 2 hours. Ensure molecular sieves (4Å) are added if the amine is sterically hindered.
Alcohol Side Product	Direct reduction of aldehyde by STAB.	STAB was added too early, or the amine is non-nucleophilic. Add amine and acid first, wait 1 hour, then add STAB.
Hydrolysis of Methoxy Group	Acid concentration too high.	Do not use mineral acids (HCl). Stick to Acetic Acid (1 equiv). Ensure reaction temp does not exceed 40°C.
Incomplete Reaction	Wet solvent (STAB decomposition).	Use anhydrous DCE. Increase STAB equivalents to 2.0 if solvent quality is suspect.

## Experimental Workflow Diagram

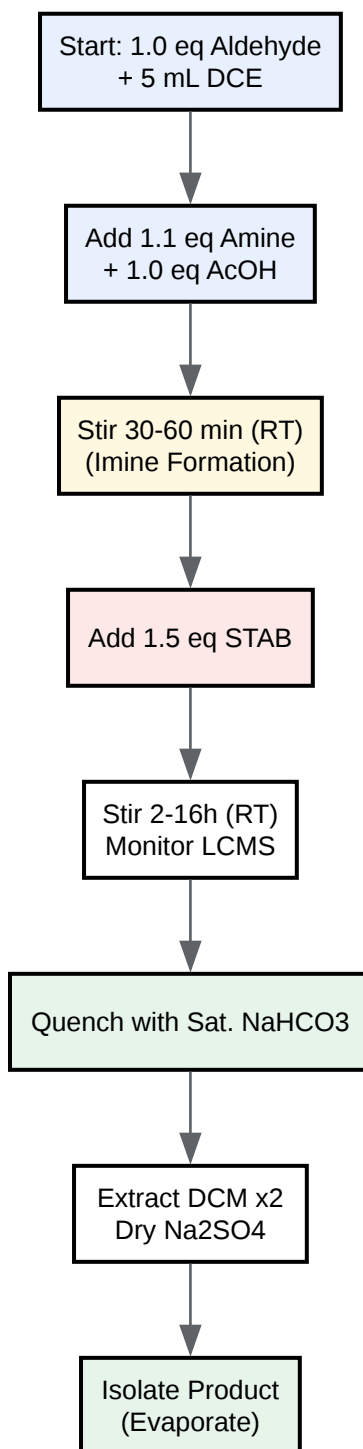

[Click to download full resolution via product page](#)

Figure 2: Operational workflow for the reductive amination process.

## References

- Abdel-Magid, A. F., et al. (1996).[3] "Reductive Amination of Aldehydes and Ketones with Sodium Triacetoxyborohydride. Studies on Direct and Indirect Reductive Amination Procedures." Journal of Organic Chemistry.
- Sigma-Aldrich. "Sodium Triacetoxyborohydride Technical Bulletin." Sigma-Aldrich.
- BenchChem. "Application Notes and Protocols for the Reductive Amination of 4-Chloroquinoline-6-carbaldehyde." BenchChem.[4][5] (Note: Protocol adapted from analogous 4-chloroquinoline scaffold).
- Organic Chemistry Portal. "Reductive Amination: Sodium Triacetoxyborohydride." Organic Chemistry Portal.

### Need Custom Synthesis?

BenchChem offers custom synthesis for rare earth carbides and specific isotopic labeling.

Email: [info@benchchem.com](mailto:info@benchchem.com) or [Request Quote Online](#).

## Sources

- [1. Reductive amination - Wikipedia \[en.wikipedia.org\]](#)
- [2. youtube.com \[youtube.com\]](#)
- [3. Reductive Amination of Aldehydes and Ketones with Sodium Triacetoxyborohydride. Studies on Direct and Indirect Reductive Amination Procedures \[organic-chemistry.org\]](#)
- [4. pdf.benchchem.com \[pdf.benchchem.com\]](#)
- [5. pdf.benchchem.com \[pdf.benchchem.com\]](#)
- To cite this document: BenchChem. [Application Note: High-Efficiency Reductive Amination of 2-Methoxy-6-Quinolinecarboxaldehyde]. BenchChem, [2026]. [Online PDF]. Available at: [\[https://www.benchchem.com/product/b13861889/docs#application-note-high-efficiency-reductive-amination-of-2-methoxy-6-quinolinecarboxaldehyde\]](https://www.benchchem.com/product/b13861889/docs#application-note-high-efficiency-reductive-amination-of-2-methoxy-6-quinolinecarboxaldehyde)

---

### Disclaimer & Data Validity:

The information provided in this document is for Research Use Only (RUO) and is strictly not intended for diagnostic or therapeutic procedures. While BenchChem strives to provide accurate protocols, we make no warranties, express or implied, regarding the fitness of this product for every specific experimental setup.

**Technical Support:** The protocols provided are for reference purposes. Unsure if this reagent suits your experiment?

**Need Industrial/Bulk Grade?** [Request Custom Synthesis Quote](#)

## BenchChem

Our mission is to be the trusted global source of essential and advanced chemicals, empowering scientists and researchers to drive progress in science and industry.

### Contact

Address: 3281 E Guasti Rd  
Ontario, CA 91761, United States  
Phone: (601) 213-4426  
Email: [info@benchchem.com](mailto:info@benchchem.com)

[Contact our Ph.D. Support Team for a compatibility check](#)