

# Technical Support: Acid-Base Extraction Workup for Amphoteric Isonicotinic Acids

**Author:** BenchChem Technical Support Team. **Date:** May 2026

## Compound of Interest

**Compound Name:** 2-[3,4-Dihydro-1(2H)-quinoliny]isonicotinic acid

**CAS No.:** 1019387-19-9

**Cat. No.:** B1385754

[Get Quote](#)

Ticket ID: ISO-ZWIT-001 Status: Open Severity: High (Process Blocking) Subject: Low recovery/solubility issues during isonicotinic acid isolation.[1]

## Introduction: The Zwitterion Trap

If you are reading this, you are likely facing a specific frustration: you have synthesized an isonicotinic acid derivative, but it refuses to leave the aqueous phase, or it refuses to precipitate upon neutralization.

The Root Cause: Isonicotinic acids are amphoteric.[1] They possess a basic pyridine nitrogen and an acidic carboxylic acid.[1] Unlike standard organic acids that are simply protonated to become lipophilic, isonicotinic acid exists as a zwitterion (inner salt) at its isoelectric point (pI). [1]

- pH < 1: Cationic (Water soluble)[1]
- pH > 6: Anionic (Water soluble)[1]

- pH  $\approx$  3-4 (pI): Zwitterionic (Net neutral, but highly polar.[1] Minimum water solubility, but often insoluble in non-polar organics like DCM or Hexanes).[1]

This guide replaces standard extraction protocols with a phase-equilibrium approach tailored for amphoteric heterocycles.

## Module 1: The Isoelectric Precipice (pH Control)[2]

The most efficient isolation method for isonicotinic acid is not extraction, but isoelectric precipitation. You must hit the pH "sweet spot" where the molecule has zero net charge.[2]

### Data: Physicochemical Properties

Parameter	Value	Significance
pKa1 (Pyridine N)	$\sim$ 1.8	Below this pH, the molecule is a soluble cation ( ).
pKa2 (Carboxylic Acid)	$\sim$ 4.9	Above this pH, the molecule is a soluble anion ( ).
Isoelectric Point (pI)	3.3 – 3.6	The target pH for maximum precipitation.[1]
Water Solubility (20°C)	$\sim$ 0.5 g/100 mL	Low enough to precipitate, provided ionic strength is managed.[1]

### Protocol A: Precision Precipitation

- Concentrate: Rotovap your aqueous reaction mixture to the minimum stirrable volume before acidification. Dilution is the enemy of precipitation.
- Cool: Chill the solution to 0–5°C.
- Adjust: Slowly add 1M HCl (if starting basic) or 1M NaOH (if starting acidic).

- Target: Stop exactly at pH 3.6. Use a calibrated pH meter, not paper (paper is too subjective for this narrow window).
- Age: Stir at 0°C for 30–60 minutes to allow crystal growth.
- Filter: Collect the precipitate. Do not wash with water; wash with cold acetone or ether (to remove organic impurities without redissolving the zwitterion).[1]

## Visualization: The Species Equilibrium

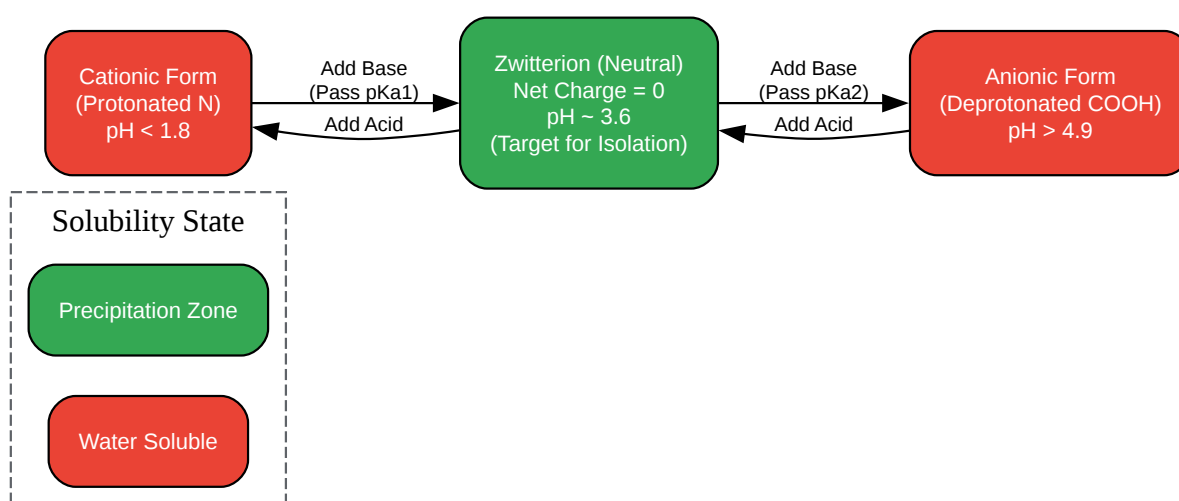

[Click to download full resolution via product page](#)

Figure 1: The acid-base equilibrium of isonicotinic acid.[3] Isolation is only viable in the green zone (pH ~3.6).

## Module 2: The Phase Transfer Dilemma (Solvent Selection)

If precipitation fails (common with highly substituted derivatives), you must extract.[1] Stop using Dichloromethane (DCM) or Ethyl Acetate. They are too non-polar to solvate the zwitterion.[1]

## The "Magic Mix" Protocol

For amphoteric compounds that resist standard extraction, you need a solvent system that can hydrogen bond with the zwitterion while remaining immiscible with water.

Recommended Solvent Systems:

- n-Butanol: The gold standard for polar extractions.[1]
  - Pros: High partition coefficient for isonicotinic acids.[1]
  - Cons: High boiling point (117°C), difficult to rotovap.[1]
- Chloroform : Isopropanol (3:1):
  - Pros: Excellent solvation of zwitterions; easier to evaporate than butanol.[1]
  - Cons: Denser than water (organic layer is on the bottom).[1]

## Protocol B: Salting-Out Extraction

This method utilizes the Hofmeister effect.[1][4][5] By saturating the aqueous phase with a kosmotropic salt (like Sulfate), you "steal" hydration water from the isonicotinic acid, forcing it into the organic phase.

- Adjust pH: Bring the aqueous phase to pH 3.6.
- Saturate: Add solid Sodium Sulfate ( ) or Sodium Chloride (NaCl) to the aqueous layer until no more dissolves.[1]
  - Note:  
Sulfate is superior for "salting out" organics (Hofmeister series), but NaCl is cheaper and usually sufficient.[1]
- Extract: Perform 3x extractions using n-Butanol or CHCl<sub>3</sub>:IPA (3:1).
- Dry: Dry the organic phase over  
anhydrous sodium sulfate  
and evaporate.

## Module 3: Advanced Recovery (Reactive Extraction)

For industrial scale-up or extremely stubborn cases, "Reactive Extraction" uses a lipophilic amine to form a hydrophobic complex with the acid.

The System:

- Extractant: Tri-n-octylamine (TOA)[1][6]
- Diluent: n-Decanol or Dodecane[1][6]

Mechanism: The TOA (dissolved in organic phase) reacts with the isonicotinic acid (in aqueous phase) to form an ion-pair complex (

) which is highly soluble in the organic layer. This is particularly effective because it pulls the equilibrium, driving high recovery.

## Troubleshooting & FAQs

### Q: I adjusted to pH 3.6, but no precipitate formed. Why?

A: Two possibilities:

- Dilution: Your solution is too dilute.[1] The zwitterion has some water solubility (0.5g/100mL). [1] If your concentration is below this, it won't crash out.[1] Fix: Rotovap aqueous layer to 1/4 volume and re-chill.
- Salt Effect (Salting In): If you used a massive amount of acid/base to adjust pH, the high ionic strength might actually stabilize the zwitterion (chaotropic effect). Fix: Switch to Protocol B (Extraction).

### Q: I have a terrible emulsion.

A: Isonicotinic acids are surfactants at certain pHs.[1]

- Fix 1: Filter the biphasic mixture through a pad of Celite.
- Fix 2: Add more salt (brine) to the aqueous layer to increase density difference.[1]
- Fix 3: If using n-Butanol, don't shake vigorously; use gentle inversion.[1]

## Q: My product is trapped in the inorganic salts after evaporation.

A: This happens if you extract with n-Butanol without drying properly.<sup>[1]</sup>

- Fix: Triturate the solid residue with hot ethanol. Isonicotinic acid is soluble in hot ethanol, but inorganic salts (NaCl/Na<sub>2</sub>SO<sub>4</sub>) are not.<sup>[1]</sup> Filter the hot ethanol and cool it to crystallize the product.

## Workflow Decision Tree

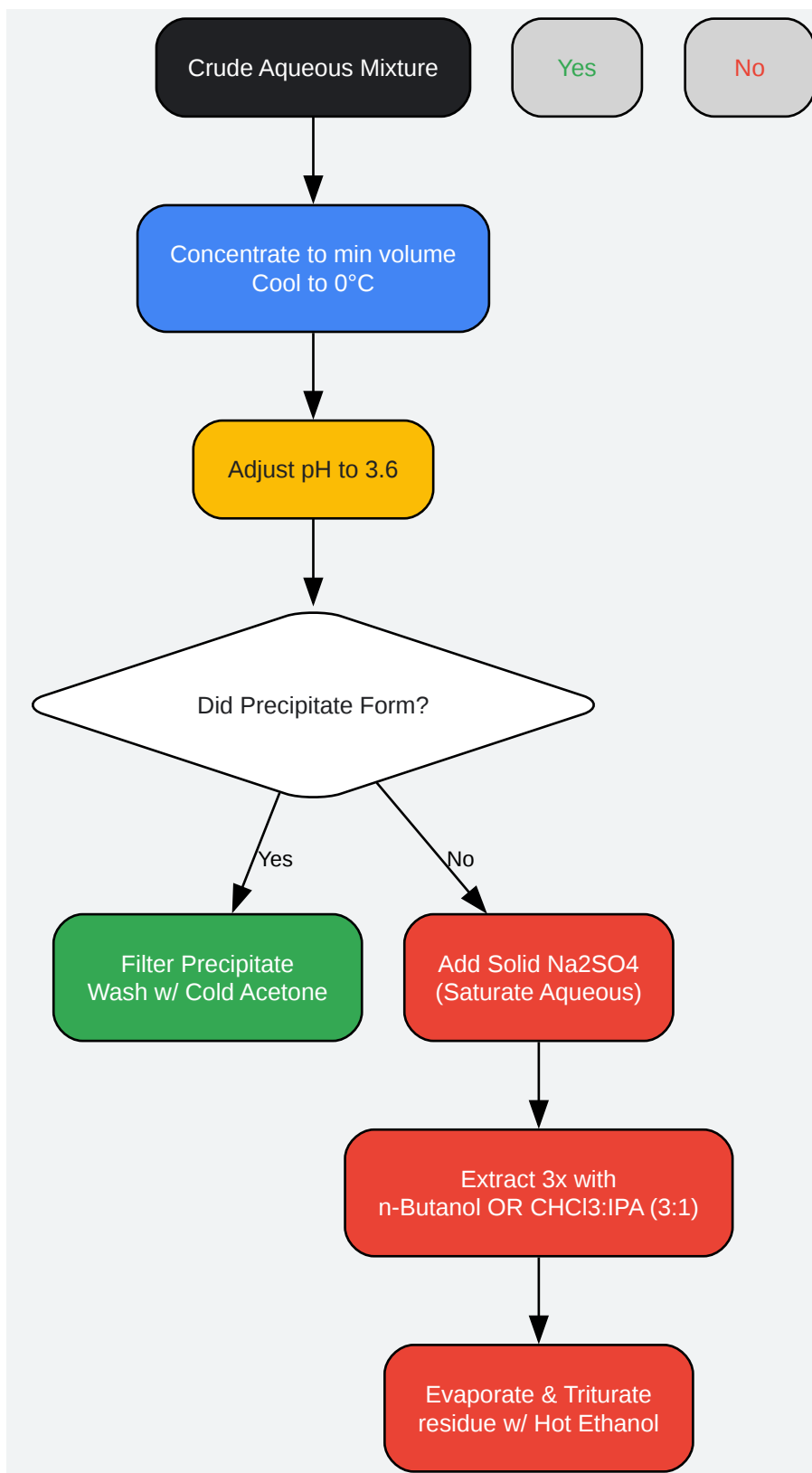

[Click to download full resolution via product page](#)

Figure 2: Logical workflow for isolating amphoteric isonicotinic acids.

## References

- Physicochemical Properties of Pyridinecarboxylic Acids.
  - Source: National Institutes of Health (PubChem) & DrugFuture.[1]
  - Data: pKa values (1.77, 4.96), Solubility data.[1]
  - Link:
- Solubility Thermodynamics.
  - Source: Journal of Chemical & Engineering Data.[1][7]
  - Data: Solubilities in water, alcohols, and binary mixtures.[8][9]
  - Link:
- Reactive Extraction Methodologies.
  - Source: ACS Omega / Industrial & Engineering Chemistry Research.[1]
  - Data: Use of Tri-n-octylamine (TOA) for intensifying recovery.[1][6]
  - Link:
- The Hofmeister Series & Salting Out.
  - Source: RSC Advances / Kinam Park Lab.[1]
  - Data: Principles of using sulfate salts to decrease organic solubility in water.[1]
  - Link:

### ***Need Custom Synthesis?***

*BenchChem offers custom synthesis for rare earth carbides and specific isotopic labeling.*

*Email: [info@benchchem.com](mailto:info@benchchem.com) or [Request Quote Online](#).*

## Sources

- [1. Isonicotinic Acid | C6H5NO2 | CID 5922 - PubChem \[pubchem.ncbi.nlm.nih.gov\]](#)
- [2. Isoelectric and Isoionic pH Explained: Definition, Examples, Practice & Video Lessons \[pearson.com\]](#)
- [3. scribd.com \[scribd.com\]](#)
- [4. researchgate.net \[researchgate.net\]](#)
- [5. kinampark.com \[kinampark.com\]](#)
- [6. pubs.acs.org \[pubs.acs.org\]](#)
- [7. pubs.acs.org \[pubs.acs.org\]](#)
- [8. semanticscholar.org \[semanticscholar.org\]](#)
- [9. researchgate.net \[researchgate.net\]](#)
- [To cite this document: BenchChem. \[Technical Support: Acid-Base Extraction Workup for Amphoteric Isonicotinic Acids\]. BenchChem, \[2026\]. \[Online PDF\]. Available at: \[https://www.benchchem.com/product/b1385754/docs#technical-support-acid-base-extraction-workup-for-amphoteric-isonicotinic-acids\]](#)

---

### Disclaimer & Data Validity:

The information provided in this document is for Research Use Only (RUO) and is strictly not intended for diagnostic or therapeutic procedures. While BenchChem strives to provide accurate protocols, we make no warranties, express or implied, regarding the fitness of this product for every specific experimental setup.

**Technical Support:** The protocols provided are for reference purposes. Unsure if this reagent suits your experiment?

**Need Industrial/Bulk Grade?** [Request Custom Synthesis Quote](#)

# BenchChem

Our mission is to be the trusted global source of essential and advanced chemicals, empowering scientists and researchers to drive progress in science and industry.

## Contact

Address: 3281 E Guasti Rd

Ontario, CA 91761, United States

Phone: (601) 213-4426

Email: [info@benchchem.com](mailto:info@benchchem.com)

[Contact our Ph.D. Support Team for a compatibility check](#)