

# Comprehensive Guide to HPLC Analysis of 3-Chloro-4-Methoxyphenyl Derivatives

**Author:** BenchChem Technical Support Team. **Date:** April 2026

## Compound of Interest

Compound Name:	(3-Chloro-4-methoxyphenyl)propylamine
CAS No.:	99177-60-3
Cat. No.:	B1385844

[Get Quote](#)

## Introduction: The Analytical Challenge

The 3-chloro-4-methoxyphenyl moiety is a critical pharmacophore and intermediate scaffold found in various pharmaceuticals (e.g., kinase inhibitors), agrochemicals (e.g., chlorpropham metabolites), and organic synthesis precursors.<sup>[1]</sup>

For the analytical chemist, this structural motif presents a unique duality:

- The Methoxy Group (-OCH<sub>3</sub>): Electron-donating, moderately hydrophobic, and capable of hydrogen bonding acceptance.<sup>[1][2]</sup>
- The Chlorine Atom (-Cl): Electron-withdrawing (inductive), lipophilic, and sterically significant.<sup>[1][2]</sup>

Separating derivatives containing this moiety—specifically from their non-chlorinated analogs (des-chloro impurities) or positional isomers (4-chloro-3-methoxy)—requires a nuanced understanding of stationary phase selectivity.<sup>[1]</sup> This guide moves beyond generic "C18 screening" to provide a mechanism-based approach for optimizing retention and resolution.

## Mechanistic Drivers of Retention

To control the retention time (

), one must understand the molecular interactions at play.[2]

### Hydrophobicity & LogP

The addition of a chlorine atom at the meta position significantly increases the partition coefficient (LogP).[2]

- 4-Methoxybenzoic acid: LogP  $\approx$  1.96[1][2]
- 3-Chloro-4-methoxybenzoic acid: LogP  $\approx$  2.7[1]
- Impact: On a standard alkyl-bonded phase (C18), the chlorinated derivative will consistently elute after the non-chlorinated parent.[1]

### Electronic Selectivity ( - Interactions)

While C18 relies on dispersive (London) forces, the chlorine atom creates a permanent dipole and alters the electron density of the aromatic ring.

- C18 Columns: Separation is driven purely by hydrophobicity.[1][2]
- Phenyl-Hexyl Columns: These phases engage in

-

stacking with the aromatic ring.[1][2] The electron-withdrawing chlorine creates a "

-acidic" character on the ring, enhancing interaction with the "

-basic" phenyl stationary phase. This often results in superior selectivity for positional isomers compared to C18.[1][2]

## Strategic Column Selection

Do not default to C18 without considering the specific derivative type.[2]

Derivative Class	Recommended Phase	Mechanism	Why?
Acids (e.g., Benzoic acid)	C18 (End-capped)	Hydrophobic Interaction	Provides max retention for polar acids at low pH.[1]
Bases (e.g., Anilines)	PFP (Pentafluorophenyl)	H-Bonding / Dipole-Dipole	Excellent peak shape for basic anilines; resolves isomers.[1][2]
Neutrals/Esters	Phenyl-Hexyl	- Stacking	Maximizes selectivity between chloro/des-chloro analogs.[1][2]

## Visualization: Column Selection Decision Tree

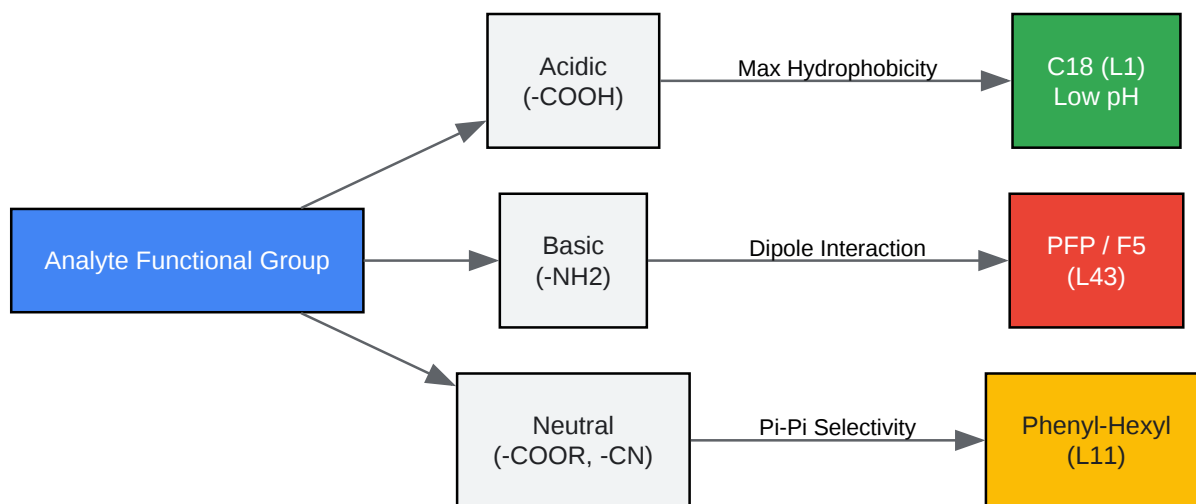

[Click to download full resolution via product page](#)

Figure 1: Decision matrix for selecting the optimal stationary phase based on the functional group attached to the 3-chloro-4-methoxyphenyl core.[1]

## Experimental Protocol: 3-Chloro-4-Methoxybenzoic Acid

This protocol is designed to separate the target compound from its common synthesis impurity, 4-methoxybenzoic acid.[1]

## Reagents & Equipment[1][2]

- System: HPLC with UV-Vis / PDA detector.
- Column: Agilent Zorbax Eclipse Plus C18 (4.6 x 150 mm, 5 µm) or equivalent L1 column.[1][2]
- Mobile Phase A: 0.1% Phosphoric Acid in Water (pH ~2.2).[1][2]
  - Why: Suppresses ionization of the carboxylic acid ( ), ensuring the analyte is neutral and retained.[2]
- Mobile Phase B: Acetonitrile (HPLC Grade).[1][2]
- Wavelength: 230 nm (optimal for chlorinated aromatics) and 254 nm.[1][2]

## Gradient Method

Time (min)	% Mobile Phase B	Flow Rate (mL/min)	Comment
0.0	20	1.0	Initial equilibration
10.0	80	1.0	Linear gradient elution
12.0	80	1.0	Wash lipophilic contaminants
12.1	20	1.0	Return to initial
15.0	20	1.0	Re-equilibration

## Expected Performance Data

The following data represents typical system suitability results for this separation.

Compound	Approx. Retention (min)	Relative Retention (RRT)	Tailing Factor ( )
4-Methoxybenzoic acid	4.2 min	1.00	1.1
3-Chloro-4-methoxybenzoic acid	6.8 min	1.62	1.0 - 1.2
3,5-Dichloro-4-methoxybenzoic acid	9.5 min	2.26	1.1

Note: The addition of Chlorine adds ~2.5 minutes of retention under these gradient conditions due to the "Hydrophobic Increment".

## Troubleshooting & Optimization

### Peak Tailing (Basic Derivatives)

If analyzing 3-chloro-4-methoxyaniline, standard C18 columns at neutral pH often yield tailing peaks due to silanol interactions.<sup>[1][2]</sup>

- Solution 1: Switch to High pH (pH 10) using an Ammonium Bicarbonate buffer and a hybrid-silica column (e.g., Waters XBridge).<sup>[1][2]</sup> The aniline will be neutral (unprotonated) and retain strongly with perfect symmetry.<sup>[2]</sup>
- Solution 2: Use a Pentafluorophenyl (PFP) column at low pH.<sup>[1][2]</sup> The fluorine atoms on the stationary phase interact with the amine, improving shape without high pH.

### Critical Pair Resolution

If the "Des-chloro" impurity co-elutes (rare on C18, common on short columns):

- Change Solvent: Switch Mobile Phase B from Acetonitrile to Methanol. Methanol is a protic solvent that interacts differently with the methoxy oxygen, often altering selectivity.<sup>[2]</sup>

- Lower Temperature: Reduce column oven from 40°C to 25°C. Lower temperature favors enthalpy-driven separations (like steric selectivity).[1][2]

## Visualization: Separation Mechanism

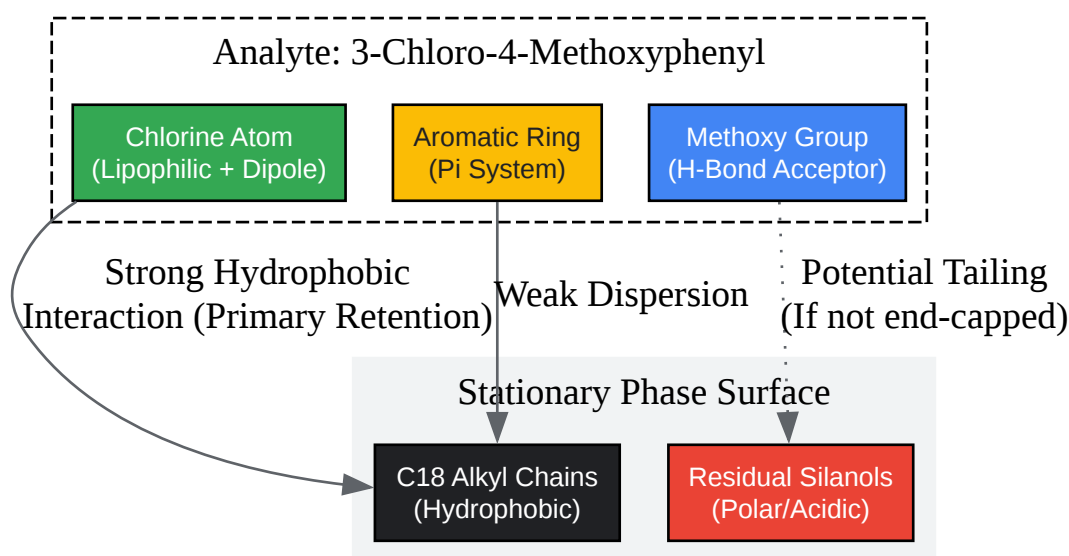

[Click to download full resolution via product page](#)

Figure 2: Mechanistic interaction map showing how specific functional groups on the derivative drive retention and peak artifacts.[1]

## References

- Benchchem. Technical Support: Managing Impurities in Industrial 4-Methoxybenzoic Acid Production. [1]
- Thermo Fisher Scientific. 3-Chloro-4-methoxybenzoic acid Product Specifications and HPLC Assay.
- Orient Journal of Chemistry. RP-HPLC Method for Content of Genotoxic 4-methoxybenzyl Chloride in Venlafaxine.
- PubChem. Compound Summary: 3-Chloro-4-methoxyaniline (CID 21441).[1][2][13]
- SIELC Technologies. Separation of 4-Methoxyaniline on Newcrom R1 HPLC column.

**Need Custom Synthesis?**

BenchChem offers custom synthesis for rare earth carbides and specific isotopic labeling.

Email: [info@benchchem.com](mailto:info@benchchem.com) or [Request Quote Online](#).

## Sources

- 1. 4-Chloro-3-methoxyaniline | C7H8ClNO | CID 13103692 - PubChem [[pubchem.ncbi.nlm.nih.gov](https://pubchem.ncbi.nlm.nih.gov)]
- 2. 3-Chloro-4-methoxyaniline 97 5345-54-0 [[sigmaaldrich.com](https://sigmaaldrich.com)]
- 3. [agilent.com](https://agilent.com) [[agilent.com](https://agilent.com)]
- 4. [lcms.cz](https://lcms.cz) [[lcms.cz](https://lcms.cz)]
- 5. 3-Chloro-4-methoxybenzoic acid, 98+% 5 g | Buy Online | Thermo Scientific Chemicals | Fisher Scientific [[fishersci.com](https://fishersci.com)]
- 6. A10106.14 [[thermofisher.com](https://thermofisher.com)]
- 7. Separation of 4-Methoxyaniline on Newcrom R1 HPLC column | SIELC Technologies [[sielc.com](https://sielc.com)]
- 8. 3-クロロ-4-メトキシ安息香酸 97% | Sigma-Aldrich [[sigmaaldrich.com](https://sigmaaldrich.com)]
- 9. [revroum.lew.ro](https://revroum.lew.ro) [[revroum.lew.ro](https://revroum.lew.ro)]
- 10. Separation of 4-Chloro-4'-methoxybenzophenone on Newcrom R1 HPLC column | SIELC Technologies [[sielc.com](https://sielc.com)]
- 11. [researchgate.net](https://researchgate.net) [[researchgate.net](https://researchgate.net)]
- 12. [lgcstandards.com](https://lgcstandards.com) [[lgcstandards.com](https://lgcstandards.com)]
- 13. 3-Chloro-4-methoxyaniline | C7H8ClNO | CID 21441 - PubChem [[pubchem.ncbi.nlm.nih.gov](https://pubchem.ncbi.nlm.nih.gov)]
- To cite this document: BenchChem. [Comprehensive Guide to HPLC Analysis of 3-Chloro-4-Methoxyphenyl Derivatives]. BenchChem, [2026]. [Online PDF]. Available at: [<https://www.benchchem.com/product/b1385844/docs#comprehensive-guide-to-hplc-analysis-of-3-chloro-4-methoxyphenyl-derivatives>]

---

**Disclaimer & Data Validity:**

The information provided in this document is for Research Use Only (RUO) and is strictly not intended for diagnostic or therapeutic procedures. While BenchChem strives to provide accurate protocols, we make no warranties, express or implied, regarding the fitness of this product for every specific experimental setup.

**Technical Support:** The protocols provided are for reference purposes. Unsure if this reagent suits your experiment?

**Need Industrial/Bulk Grade?** [Request Custom Synthesis Quote](#)

## BenchChem

Our mission is to be the trusted global source of essential and advanced chemicals, empowering scientists and researchers to drive progress in science and industry.

### Contact

Address: 3281 E Guasti Rd  
Ontario, CA 91761, United States  
Phone: (601) 213-4426  
Email: [info@benchchem.com](mailto:info@benchchem.com)

[Contact our Ph.D. Support Team for a compatibility check](#)